



M Series | Mechanical VRC

Owner's Manual with NORD Motordrive

Important:



**Read this entire manual.
Important safety information
is included.**

The illustrations depicted in this manual are not to scale or detail. The illustrations are for reference only.





Description		Section Page
1. Contact Information	15705-0011	1 1
2. General Information	15710-0004	2 1
Introduction		2 1
General Overview		2 1
Code Requirements		2 1
Parts		2 1
Service		2 1
Feedback		2 1
3. Warranty Information	15710-0014	3 1
Parts and Labor		3 1
Definitions		3 1
Warranty		3 1
Exclusions		3 1
Obligation		3 1
Liability		3 2
Warranty Procedures		3 2
Pre-Authorization		3 2
Invoices		3 2
4. Important Safety Information	15708-0200-01	4 1
Read the Entire Manual		4 1
Intended Purpose		4 1
Potential Risks and Possible Misuse		4 1
Safety Alert Symbols		4 1
Danger Statements		4 2
Warning Statements		4 2
Caution Statements		4 4
Electrical Safety Precautions		4 5
De-energize the Circuit		4 5
Electrical Safety Precautions		4 6
Working on Energized Circuits		4 6
Notes for the Installation Electrician		4 6
Entrance Below a Raised Carriage Deck	15709-0083	4 7
5. Glossary	15710-0018	5 1
Unique Descriptions and Names		5 1
Gate Types		5 8
Identifying Call Outs		5 9



Description		Section Page
6. Electrical Standards and Definitions	15709-0085	6 1
Field Electrical Wiring Standards		6 1
Definitions		6 1
Requirements		6 1
Electrical Ruling Bodies		6 2
PFlow's Standard		6 2
Outdoor Application		6 2
Corrosive Application		6 2
Hazardous Location		6 3
Class Definitions		6 3
Division Definitions		6 3
Group Designations		6 3
7. Mechanical Overview	15705-1020	7 1
Lift Columns		7 1
Straddle and Cantilever Configuration		7 1
Drivebase Assembly		7 2
Safety Cam and Roller Guides		7 3
Safety Cam Function		7 5
Enclosures		7 6
Gate Assemblies		7 7
8. Electrical Overview	15709-0006	8 1
Main Control Panel		8 1
Push-button Stations		8 1
Main Disconnect		8 1
Drivebase Assembly		8 1
Control Switches		8 2
9. Sequence of Operation	15705-1013	9 1
Sequence		9 1
Important Safety Information		9 4
To Operate the Lift		9 5



Description		Section Page
10. NORD Motor Identification and Operation	15709-0101	10 1
Safety Warnings		10 1
Environment		10 2
Ambient Temperature		10 2
Directive and Standards		10 3
Labeling		10 3
Type Code		10 3
Reducer Nameplate		10 4
Motor Options and Nomenclature		10 5
Motor Option Codes		10 5
Operation of the Brake		10 6
Brake Running Operation		10 7
11. NORD Motor Maintenance and Troubleshooting	15709-0102	11 1
Safety Warnings		11 1
Basic Brake Operation		11 2
Brake Air Gap		11 3
Hand-Lever Air Gap Values		11 3
Brake Maintenance		11 4
Adjust the Air Gap		11 4
Troubleshooting the Brake		11 5
Removing the Brake		11 6
Disposal of the Brake and Gear Motor		11 6
Gearbox Lubrication		11 7
Lubrication Replacement		11 7
Maximum Oil Temperature		11 7
Oil Drain and Fill-level Plugs		11 8
Oil Formulation Codes		11 8
Oil Lubricants		11 8
Ambient Temperature		11 8
Lubrication Notes		11 9
Oil Cross-reference Chart		11 9
Oil Volume		11 10
Oil Plug Connections		11 11
Troubleshooting the Reducer		11 12

Table of Contents



MATERIAL HANDLING SOLUTIONS

www.pflow.com
 P 414 352 9000
 F 414 352 9002
 6720 N. Teutonia Ave.
 Milwaukee, WI 53209

Description		Section Page
12. Cleaning	15709-0088	12 1
Important Safety Information		12 1
Cleaning		12 1
13. Preventive Maintenance and Schedule Checklist	15705-0023	13 1
Important Safety Information		13 1
Checklist		13 2
14. Troubleshooting	15705-0021	14 1
15. Adjust Overcurrent Sensor	15709-0052	15 1
16. Recommended Spare Parts	15705-1022	16 1
17. Parts	15705-1024	17 1
Drivebase Assembly		17 1
Chain Loop Arrangement		17 2
Chain Tensioner Assembly		17 3
Interlocks		17 4
Gate Status Switches		17 6
Safety Cam Assembly		17 7
Guide Roller Block Assembly		17 8
Twin Roller Guide Assembly		17 9
Single Roller Guides Assembly		17 12
18. Recommended Storage Requirements	15709-0080-2	18 1
Stacking		18 1
Long Term Storage		18 1
Storage for Longer than Six Months		18 2
Equipment Manuals		18 2
19. Signage Locations	15709-0035	19 1
Installation Questionnaire	15708-1500	Forms 1
Acceptance Certificate - VRC	15710-0017-VRC	Forms 1

Table of Contents



MATERIAL HANDLING SOLUTIONS

www.pflow.com
P 414 352 9000
F 414 352 9002
6720 N. Teutonia Ave.
Milwaukee, WI 53209





PFlow Industries, Inc.
6720 N. Teutonia Avenue
Milwaukee, Wisconsin 53209



Office
Phone: 414-352-9000
Fax: 414-352-9002



Customer Support Department
e-mail: csd@pflow.com



Sales
e-mail: sales@pflow.com

For a list of contact personnel visit the PFlow Industries, Inc. website at:
<https://www.pflow.com/contact>

Documentation

PFlow Industries, Inc. reserves the right to make changes or improvements to the standard model line at any time. PFlow Industries, Inc. reserves the right to make changes to subsequent editions of the manual without prior notice to holders of this edition.

Copyright Notice

© Copyright February 2024 by PFlow Industries, Inc.

All rights reserved.

No part of this manual may be reproduced or used in any form without expressed written permission from PFlow Industries, Inc.

This publication may be photocopied by the original purchaser. Any other type of reproduction is prohibited without express written permission from PFlow Industries, Inc.

Trademarks

All trademarks referenced in this manual are the property of their respective owners.

System Modifications/Disclaimer

Mechanical or electrical modifications performed on the equipment not approved by PFlow Industries, Inc. may void any warranty and/or service agreements. Please contact the PFlow Customer Support Department for assistance with service modifications.

Training

Training is available upon request from the Customer Support Department. Half-Day, Full-Day, and Two-Day sessions are customized to fit specific needs - either for a single equipment type or for the entire product line.

On-site Supervision

On-site supervision services are available from the Field Service Department. Contact our Field Service Manager for more details.

Source Language

This manual is written in American English.

Section 1 | Contact Information



MATERIAL HANDLING SOLUTIONS

www.pflow.com
P 414 352 9000
F 414 352 9002
6720 N. Teutonia Ave.
Milwaukee, WI 53209





Introduction	This manual provides information about the PFlow Industries, Inc. custom designed Vertical Reciprocating Conveyor (VRC). As the nations' leading manufacturer of vertical material handling equipment, PFlow Industries, Inc. is confident that this new VRC will provide many years of reliable service.
General Overview	The VRC provides a safe and simple means of moving material from one level to another. The simplicity of design and few moving components ensure a trouble-free, long life, with low maintenance and little downtime.
Code Requirements	<i>This VRC is designed for the movement of materials only, up to the VRC's rated capacity, from one level to the next. Do not allow anyone to ride on the VRC.</i> VRCs are not elevators, and are specifically excluded within the scope of the ASME A17.1 Safety Code for Elevators and Escalators. VRCs are included in ASME B20.1 Safety Standard for Conveyors and Related Equipment, which is incorporated by reference into OSHA 29 CFR 1910. A copy of the ASME B20.1 standard can be purchased at www.asme.org and other sources. PFlow Industries, Inc. recommends that this standard be referenced for appropriate installation, maintenance, inspection, and operation in relation to hazards. All electrical designs and components are in accordance with National Electric Code (NEC) requirements. Local codes may require initial inspection of the installation and periodic inspection and testing of the unit. Contact PFlow Industries, Inc. for more information in the event an inspection is required.
NOTE	<i>The information and illustrations in this manual are intended only as an aid to understanding the VRCs general installation. The information and illustrations do not cover every possible contingency or circumstance regarding nonstandard options or site conditions.</i>
	If there is a problem, call PFlow Industries, Inc. at (414) 352-9000, during normal business hours, 8:30 a.m. to 5:00 p.m. central standard time, Monday through Friday. Outside of those hours, see the PFlow Industries, Inc. Contact Information page for additional information. Use the model number and serial number or the PFlow Industries, Inc. General Arrangement (GA) drawing number for the lift in all correspondence.
Parts	Equipment damage resulting from modification in any manner from the original model, including the substitution of parts other than factory authorized parts, will void the warranty. Furthermore, PFlow Industries, Inc. will not be liable for any loss, injury, or damage to persons or property, nor for direct, indirect, or consequential damage of any kind resulting from modified or substitution of parts other than factory authorized parts of said material or equipment. PFlow Industries, Inc. maintains a complete stock of, or has access to, all replacement components. Detailed records of all equipment sold are kept. If a component is damaged in shipment, is defective or missing, contact PFlow Industries immediately.
Service	The PFlow Industries, Inc. Customer Support Department will assist maintenance and service personnel with any questions or problems regarding the equipment or installation.
Feedback	Your feedback is important. Please help PFlow Industries, Inc. understand if the equipment has met your expectations. Please complete the questionnaire in this manual. The questionnaire will help us address any comments and/or concerns.

Section 2 | General Information



MATERIAL HANDLING SOLUTIONS

www.pflow.com
P 414 352 9000
F 414 352 9002
6720 N. Teutonia Ave.
Milwaukee, WI 53209





Parts and Labor

Parts:		Labor:	
Structure	Lifetime	Structure	Lifetime
Manufactured Components	1 Year	Manufactured Components	1 Year
Purchased Components	1 Year	Purchased Components	Supplier
Gates and Enclosures	90 Days	Gates and Enclosures	90 Days

Definitions

- Structure is defined as columns, carriage, and pre-fabricated bracing (excluding carriage side guards).
- Manufactured components are defined as those components manufactured by PFlow Industries, Inc.
- Purchased components are those components that are used as supplied by vendors and covered by the Supplier’s labor warranty.

Warranty

PFlow Industries, Inc. expressly warrants to the original purchaser that this product will be free from defects in material and workmanship under normal, intended use. The warranty period begins 60 days after shipment.

Exclusions

This warranty does not apply to:

1. Equipment or components damaged or broken in transit or shipping.
2. Replacement of wear parts.
3. Equipment failures caused by abuse, misuse, exceeding recommended capacities, impact with other objects, negligence, improper installation, unskilled use, unskilled maintenance, inadequate maintenance, or incorrect adjustments.
4. Exposure to a corrosive or abrasive environment or exterior elements unless specifically built for that environment.
5. Equipment that has been repaired, altered or modified in any manner outside of the manufacturing facility, substitution of parts other than factory authorized parts, removal of any parts, or addition of any parts without prior written permission by PFlow Industries, Inc.
6. Any losses or damages resulting from loss of data, loss of revenue or profits, loss of products, incidental or consequential damages, delays, or expenses incurred by failure of said part or parts even if advised of the possibility thereof.
7. Lost time and/or additional trips for missing or damaged components.
8. Expedited freight charges.

Obligation

The obligation for PFlow Industries, Inc. is limited to only the replacement or repair of defective components that received prior authorization. This is the owner’s sole remedy.

PFlow Industries, Inc. will bear normal labor charges performed by an authorized PFlow Industries, Inc. service agent during standard business hours, excluding overtime, holiday rates, or any additional fees.

This warranty applies to all models and no person except an officer of PFlow Industries, Inc. is authorized to modify this warranty or to incur on behalf of PFlow Industries, Inc. any other obligation or liability in connection with PFlow Industries, Inc. equipment.



Liability

PFlow Industries, Inc. believes, to the best of our knowledge, that the information in the equipment manuals are accurate. In the event that technical or typographical errors exist, PFlow Industries, Inc. reserves the right to make changes to subsequent editions of the manual without prior notice to holders of this edition. The reader should consult PFlow Industries, Inc. if errors are suspected.

The customer’s right to recover damages caused by fault or negligence on the part of PFlow Industries, Inc. shall be limited to the amount paid to PFlow Industries, Inc. by the customer. The limitation of liability of PFlow Industries, Inc. will apply regardless of the form of action, whether in contract or tort, including negligence. Any action against PFlow Industries, Inc. must be brought within one (1) year after that cause of action accrues.

PFlow Industries, Inc. will not be liable for any loss, injury, or damage to persons or property, nor for direct, indirect, or consequential damage of any kind resulting from failure or defective operation of said material or equipment.

Warranty Procedures

All billing must be in accordance with our Warranty Procedures. Replacement of defective parts will be handled in accordance with the Return Materials Authorization (RMA) policy for PFlow Industries, Inc.

Pre-Authorization

- All warranty work must be pre-authorized by PFlow Industries, Inc. Customer Support Department prior to starting work.
 - Where distance and or experience may be more cost-effective, PFlow Industries, Inc. reserves the right to use alternate organizations.
 - Labor is defined as a maximum of two hours travel per call, plus reasonable on-site repair time as determined by PFlow Industries, Inc.
 - Local purchase of components must be pre-authorized.
1. Notify the PFlow Industries, Inc. Customer Support Department of the problem for authorization.
 2. PFlow Industries, Inc. will determine:
 - The cause of the problem.
 - Who will do the repair work.
 - The repair details involved.
 3. If PFlow Industries, Inc. decides that your organization or your subcontractor will do the work, an authorization number will be assigned which must be referenced on all subsequent paperwork.

NOTE *Notify PFlow Industries, Inc. by phone, FAX, or e-mail during the next business day if an event occurs during our non-working hours. Issuance of an authorization number does not guarantee approval and/or payment.*

Invoices

1. Submit an invoice for approval within 30 days after the date the work was completed. Payment is made 30 days after the date of approval.
2. A deduction from outstanding payments to PFlow Industries, Inc. for warranty is never authorized.
3. Invoices received without sufficient information will be returned. Invoices will be reconsidered for approval when complete documentation is received. All invoices must include, in detail, the following:

<input type="checkbox"/> PFlow serial number.	<input type="checkbox"/> Labor hours expended resolving the problem.
<input type="checkbox"/> Date the work was performed.	<input type="checkbox"/> Rates per hour.
<input type="checkbox"/> Description of the problem.	<input type="checkbox"/> Copies of receipts for materials purchased.
<input type="checkbox"/> Travel time incurred.	<input type="checkbox"/> Detailed description of work completed.



Read the Entire Manual

Important: Carefully read the entire manual upon receipt of the VRC. Improper installation, alteration, adjustment, service, cleaning, or maintenance could result in death, severe injury, or property damage. Instructions and warnings must be read and thoroughly understood by all operators and users. PFlow Industries, Inc. recommends that the owner conduct regular staff training including safety instructions on a regular basis to avoid the risk of accident or damage to the VRC.

Following procedures other than those indicated in this guide to install, use, and maintain the VRC is considered inappropriate and may cause fatal accidents, personal injury, or property damage, in addition to invalidating the warranty.

Intended Purpose

The intended purpose of the PFlow Industries, Inc. Vertical Reciprocating Conveyor (VRC) is to provide a safe and simple means of moving materials only, up to the VRCs rated capacity, from one level to another. VRCs are **not** elevators. The VRC is exclusively intended for use in establishments where all operators have been trained to understand the purpose, limitations, and associated hazards of the VRC. Any other use is strictly forbidden.

Potential Risks and Possible Misuse

PFlow Industries, Inc. has attempted to protect against as many hazards as possible. The following potential risks should be addressed before the VRC is put into operation:

- Risk of injury caused by falling products.
- Risk of injury caused by product extending beyond the confines of the carriage.
- Risk of injury caused by exceeding the weight capacity of the VRC.
- Hazards occurring at places where the VRC connects to incoming and outgoing conveyors.
- Risk of injury if any safety features are bypassed.
- Risk of injury due to the use of corrosive chemicals or water jet.

Safety Alert Symbols

To ensure your safety and the safety of those around you, it is important that you read, observe, and understand ALL safety precautions relative to a particular task. Safety precautions in the manual are labeled with an alert symbol followed by the word **DANGER**, **WARNING**, or **CAUTION**.



This is the safety alert symbol. It is used to alert you to potential physical injury hazards. Obey all safety messages that follow this symbol to avoid possible injury or death.



Indicates a hazardous situation that, if not avoided, will result in death or serious injury.



Indicates a hazardous situation that, if not avoided, could result in death or serious injury.



Indicates a hazardous situation that, if not avoided, could result in minor or moderate injury.

NOTICE



Used to address practices not related to physical injury.







 **DANGER**

- Stay within the rated lift capacity.
- Make sure all safety devices are in place and operable before using the equipment. If any safety device is missing or inoperable, immediately remove the equipment from service.
-  High Voltage! A qualified electrician must install all electrical connections and permanent wiring in accordance with applicable local or national electrical codes. Make sure the equipment is properly grounded in accordance with local electrical codes or, in the absence of local codes, with the current edition of the National Electrical Code NFPA No. 70.
- Falling column hazard! Make sure all beams, columns, posts, enclosure panels, and components are properly supported during installation. Illustrations may show the beams, columns, posts, enclosure panels, and components unsupported in order to make the equipment and installation instructions clearly understood.
- Keep clear of unsupported platforms. Stay out of the area under a raised platform. If a maintenance operation requires the carriage to remain in the raised position, refer to Bulletin 15709-0083 for additional information or contact PFlow Industries, Inc. Customer Support Department for assistance.

 **WARNING**

- This equipment can be dangerous if not used properly. Allow only competent adults who have been properly trained and authorized personnel to operate this equipment.
-  Passengers are not permitted. Riding may result in death or serious personal injury.
- This equipment must be maintained to ensure safety. Allow only properly trained personnel to service the equipment. Implement a routine safety inspection plan and follow the recommended preventive maintenance schedule in the owner's manual.
-  Lockout/tagout equipment before performing any adjustments or maintenance. If the equipment is not locked out, it could start unexpectedly and cause injury or damage. **Make sure all personnel are aware of the potential for stored energy to be present even after the power has been locked out.** Refer to ANSI Z244.1 and OSHA 29 CFR 1910.147 for minimum requirements for a lockout/tagout system. There may be additional state or local requirements.
-  Components and accessories may be heavy. To prevent serious injury, use the appropriate lifting apparatus when handling the components and installing the VRC.

WARNING

- If any defects relating to operating safety and reliability are detected or if any damage occurs, the VRC must be taken out of operation immediately.
- Before the VRC is put into operation, all VRC parts must comply with all relevant health and safety directives and regulations.
- Do not switch the main power supply on or start the VRC when persons are in contact with the VRC.
-  Make sure that no persons or objects are within the range of any moving parts of the VRC.
-  Climbing, sitting, walking, or riding on equipment while the equipment is in operation could result in death or serious injury.
- If this VRC needs to be modified in any way, contact PFlow Industries, Inc. for assistance. Do not make any unauthorized changes.
-  **Falling Hazard!** Close all gates before the carriage is moved. Never leave the lift unattended with the gates in the open position. Never close gates when a person is on the carriage or within the fenced area.
- Place the load in the center of the carriage platform to avoid shifting loads. Lock rolling casters in place. Make sure that any portion of the load does not overhang the perimeter of the carriage. Prevent unstable load conditions.
- If the carriage deck does not stop after contact has been made with the limit switch arm, or continues to drift past the floor level, the lift motor brake is not working properly. Discontinue use of the VRC and contact PFlow Industries, Inc. for assistance.
-  Lockout/tagout the VRC before removing jammed product. Be aware that stored energy in the lift components may move or shift when the jam is removed. De-energize any circuit before work is begun.
- Do not overtravel! Stops, mechanical or electrical, must be in place to prevent the carriage from traveling beyond the intended floor level. Overtravel could cause permanent damage to the carriage or failure of the lifting mechanism.
-  **Entanglement hazard!** Secure long hair, wear snug-fitting clothing, and avoid wearing jewelry while using the VRC.



 **CAUTION**



- Inform personnel about the location and operation of emergency stops and power disconnection points.
 - During operation, the surfaces of some components may become hot. Avoid touching hot surfaces or wear protective gloves.
 - If any unsafe or unusual conditions are observed, stop the equipment and remove it from service. Report the condition to your supervisor.
-

Electrical Safety Precautions

 **DANGER**



High Voltage! Employees servicing or maintaining VRCs may be exposed to death or serious personal injury if hazardous energy is not properly controlled. De-energize any circuit before work is begun. Follow your facilities procedures or OSHA lockout/tagout (LOTO) procedures anytime maintenance or service is being performed on any electrical box or component.

 **CAUTION**

The incoming voltage source must match the voltage identified on the rating tag. The rating tag provides essential technical information required for any installation, maintenance, or repairs. Do not remove, damage, or modify the rating tag.

De-energize the Circuit

1. Lockout/tagout whenever any work, maintenance, or service is performed on any electrical box or component. Make sure circuits are de-energized before starting work, using a functional, properly rated, and well maintained multimeter or voltage sensing device. Make sure the device is rated for the level of voltage being measured and is sensitive enough for the application.
2. Use fuse pullers to change a fuse; **never** use bare hands, pliers, or screwdrivers.
3. Install covers on exposed electrical devices or wires to protect personnel from serious injury.
4. Ground all metal connection boxes, switch boxes, starting boxes, transformers, motors, limit switches, interlocks, and push-button stations to prevent shock to personnel.
5. When using a portable meter, never leave one lead dangling with the other lead connected. Anyone touching the lead may receive a shock through the meter.
6. Make sure that all is clear following lockout/tagout procedures before applying power to a circuit. This is necessary in order to protect personnel from injury and to prevent damage to the equipment.
7. Avoid accidental contact with equipment or conductors which are known to be energized or are **not** known to be de-energized. If it is necessary to work on equipment while it is energized, use extra care. Always test and repair equipment that appears damaged or delivers an electric shock.

Take time to be careful! Follow all safety precautions to prevent death or personal injury.

Electrical Safety Precautions

 **DANGER**



High Voltage! To prevent serious injury, death, or property damage, all electrical connections and permanent wiring must be installed by a licensed electrician in accordance with applicable local or national electrical codes. Arc flash and shock hazard appropriate PPE is required. This equipment must be adequately grounded in accordance with local electrical codes or, in the absence of local codes, with the current edition of the National Electrical Code NFPA No. 70.

Working on Energized Circuits

When electrical repair or maintenance work is required that prohibits de-energizing the circuits involved, extreme caution must be used. The work should be completed only by authorized, well trained and supervised personnel who are fully aware of the dangers involved. All practical safety measure must be used to protect the personnel performing the required work. In addition to the NFPA No. 70 codes, the following precautions **must** be taken:

1. Remove all wristwatches, watch chains, rings, necklaces, metal appendages to clothing, oversized metallic belt-buckles, metal piercings, or loose clothing. These items have the potential to make accidental contact with energized surfaces. In addition, secure long hair with a hair net or cover with a plastic helmet.
2. Remove all hair barrettes or bobby pins. These items are electrically conductive and accidental contact may cause serious personal injury.
3. Wear dry clothing and shoes. Moisture should not be present on the soles of shoes. Water is electrically conductive and accidental contact may cause death or serious personal injury.
4. Insulate the worker from the ground. Cover any adjacent grounded metal surfaces with an insulating material. Suitable insulating materials are dry wood, rubber mats, dry canvas, dry phenolic material, or heavy, multi-ply paper (cardboard). Make sure that the insulating material has no holes present and there are no conductive materials (e.g., staples) embedded. Cover a sufficient area with the insulating material to make sure that adequate space is permitted for worker movement.
5. Use insulated tools when working on energized circuits or fuse box. These insulated tools must be rated to withstand the voltage of the energized circuits.

Notes for the Installation Electrician

The installation electrician must take the following precautions:

1. Locate and review the electrical schematics furnished with the equipment.
2. Verify the proper fit-up, wiring and operation of all required electrical components.
3. Mount the push button station out of reach of someone located on the carriage (approximately 6' [1,829 m]).
4. Wire standard lift limit switches on the chain tensioning assembly (see the job specific electrical schematic as required) for mechanical VRCs as follows:
If the tensioner chain becomes slack causing the arm on the limit switch to move down or if a strong tension is exerted on the tensioner chain causing the arm to move up, there is a break in the control power. The limit switches are designated with an LS# on the electrical schematic.



Safety First

The most common reason to access the area below a raised carriage deck is to clean debris from the pit or hoistway. This is best accomplished using a long handled broom or rake to avoid entry under the raised carriage deck. Entry under the raised carriage deck is acceptable only when unavoidable and then only if the proper precautions are taken. It is the user's responsibility to ensure that the following conditions be met before allowing qualified personnel to enter the area under the raised carriage deck.

- Work must be performed by qualified maintenance technicians.
 - ◇ A qualified person is defined as a person who, by possession of recognized degree or certificate of professional standing or by extensive knowledge, training, and experience, has successfully demonstrated his/her ability to solve problems relating to the subject matter and work.
- The facility has performed a Risk Assessment per ASME B20.1 5.16
 - ◇ Reference OSHA 3071 for Job Hazard Analysis
 - ◇ Reference CEMA Technical Report 2015-01, ASSE Z590.3, and MIL-STD-882 for Risk Assessment examples.
- A proper lockout/tagout (LOTO) procedure has been performed on the VRC.
 - ◇ Refer to ANSI/ASSE Z244.1-2003 (R2014), Control of Hazardous Energy — Lockout/Tagout and Alternative Methods, and OSHA Standard 29 CFR 1910.147, The Control of Hazardous Energy (Lockout/Tagout).
- At least two (2) means of support are used to secure the raised platform.
 - ◇ The lifting systems can be used as one means of support provided that no work is to be done on the hydraulic system or mechanical drive system and an appropriate LOTO has been performed on the VRC.
 - ◇ Additional means of support include adequately sized maintenance chains, maintenance pins, DeckLocks, or straps with shackles around the drivebase that are capable of supporting the weight of the carriage.

Minimize the Hazards

Every employee must be aware of the hazards before entering the area under a raised carriage. Take appropriate steps to minimize these hazards and any others that are identified. Some of the more common hazards are:

- Inadequate refuge space
- Confined space
- Improper air quality
- Inadequate lighting
- Improper access
- Tripping hazards
- Unsafe or lack of pit ladders
- The presence of moisture/water/oil
- Moving equipment

General Guidelines

- Where a VRC is operating in a multiple unit hoistway, that portion of the hoistway where the work is to be performed shall be fully separated or accessible equipment locked out.
- Ensure that all portable lights and tools are connected through a Ground Fault Circuit Interrupter (GFCI).
- Provide adequate lighting especially if in a shaftway.
- For a deep pit, never "jump" into the pit – always use a ladder.
- Use proper hand protection while cleaning the area beneath a raised carriage.
- Remove parts, lubricants, cleaning equipment, etc. from inside the pit.
- Do not stand on the hydraulic piping or electrical conduit.
- Never straddle over the traveling cable(s) if so equipped and protect it against damage.

Entrance Below a Raised Carriage Deck



MATERIAL HANDLING SOLUTIONS

www.pflow.com
P 414 352 9000
F 414 352 9002
6720 N. Teutonia Ave.
Milwaukee, WI 53209

Pit Access

Access to the area beneath the raised carriage deck can be gained through manual measures implemented by qualified maintenance technicians.

Manual Access

1. Call the carriage to the lower level.
 2. Open the lower gate and bypass the gate open switch at the interlock or in the main control panel. If there is any confusion about how to do this, call PFlow Industries, Inc. Customer Support Department.
 3. Barricade the lower level gate opening to prevent unintended access and provide hazard warning signs.
 4. Verify that the carriage is empty. Raise the carriage to the upper level making sure all personnel are clear of the moving carriage.
 5. Lockout the VRC in accordance with the facility lockout/tagout program.
 6. Secure the carriage at the upper level using adequately sized maintenance chains, maintenance pins, or straps with shackles around the drivebase that are capable of supporting the weight of the carriage to provide additional safety.
-

NOTICE

Do not attempt to do any work on the lifting system (e.g., hydraulic system, motor drive). When work is to be done on the hydraulic system or mechanical drive system, a different procedure must be followed. The carriage must be landed on stands or secured by another means in order to prevent any weight from relying on the lifting means or when the hydraulic pressure is fully relieved. Consult PFlow Industries, Inc.

7. Return to the lower level and verify that the gate and the carriage does not move if the push-buttons are pressed. Wedge or block the lower level gate in the open position to prevent the gate from closing while someone is in the pit area.
 8. Perform the necessary maintenance, adjustments, or cleaning under the carriage.
 9. Exit the pit and remove the wedge or block holding the lower level gate open.
 10. Reverse the process to return the VRC into service.
-



Unique Descriptions and Names

PFlow Industries, Inc. has incorporated, as well as created, a number of unique descriptions, names, and terminology for parts, components, and devices included in the Vertical Reciprocating Conveyor (VRC). This glossary includes these unique terms and other common terms to help understand this manual and the information it contains. In addition, the glossary will aid the user in communicating the correct information during troubleshooting and service situations. Although the wording and descriptions may sound familiar to the person who has read the manual, other terms and descriptions might not. It is recommended by PFlow Industries, Inc. that this glossary be reviewed before reading the remainder of this manual.

Alkyd paint	A fast-drying enamel paint, color-mixed per the customer's request, and applied using standard methods as specified by the paint manufacturer.
ANSI	American National Standards Institute: www.ansi.org
ASME	American Society of Mechanical Engineers: www.asme.org
Authorized person	Trained or qualified personnel approved to perform a specific duty or duties.
Back-frame	The vertical portions of the carriage on a cantilever VRC, typically a series D vertical support mast.
Backstop panel	Also known as a Mezzanine roll-off panel, this is a panel that is installed opposite the loading edge at upper loading levels of a VRC platform that does not penetrate a floor. The backstop panel helps protect personnel and/or products from falling off the platform when loading or unloading. This term should not be confused with the term "backstop" as defined in ASME B20.1.
Backstop	As defined by ASME B20.1; A mechanical device to prevent reversal of a loaded conveyor under action of gravity when forward travel is interrupted.
BVAC	A bi-panel vertical acting gate.
Cantilever	A style of VRC where the carriage rides along the guide columns that are located on the same side of the carriage. This style lift can accommodate loading on three sides; right, front, and left.
Capacity	The maximum load for which the VRC is designed.
Carriage	The entire structural assembly that travels on the guide columns and carries the load.
Carriage gate	A gate that is mounted directly on the carriage deck.
CEMA	Conveyor Equipment Manufacturers Association: www.cemanet.org
Chain	See Drive chain, Lift chain and Roller chain.



Chain Driven Live Roller (CDLR)	A horizontal conveyor that is driven by separate loops of chain or a continuous chain. The chain contacts all roller sprockets, depending on the type and function of the horizontal conveyor. Either double or single sprockets are fitted to the horizontal conveyor rollers.
Chain Guide Tube	A tube welded to the back side of the VRC column that encloses the lift chain and tensioner chain.
Chain tensioner	A device that monitors the lift chain tension. If the lift chain is too tight, becomes slack, or breaks, the limit switch mounted on the chain tensioner will trip and remove control power.
Columns	The vertical structural members in which the wheelblocks attached to the carriage travel up and/or down.
Column splice	Columns shipped in more than one piece must be joined in the field during installation. Field assembly and welding is required.
Constant Pressure Push Button	A push button which must remain pressed and maintained by the operator in order to perform a desired operation. If the push button is released, the desired operation will stop.
Controls	Any combination of electrical devices used to control the operation of a VRC. This normally includes push buttons, relays, limit switches, interlocks, etc.
Control Panel	An enclosure housing various electrical components that control the VRC.
Control voltage	The control voltage is typically provided by the control transformer and is used to energize the various low voltage electrical devices.
Conveyor, Vertical Reciprocating	See Vertical Reciprocating Conveyor (VRC).
Dead load	A static load that is a permanent force, acting on a structure (see Platform).
Deck	The floor of the carriage (can be smooth plate, tread plate, or open).
DeckLock System	An added measure of safety to prevent uncontrolled descent of the carriage.
Diagonal drop bar	Load-defining bar and snap chain across operating end(s) of the carriage to define the load area on the platform which may minimize load movement. The diagonal drop bar is hinged at the base and swings down. This is not a load stop.
Direct acting cylinder	The cylinder which transmits lifting force directly to the carriage rather than through the use of cables, pulley, or chains.
Drivebase assembly	Gear reducer, brake motor and mechanical components that power the chain that lifts and lowers the carriage for mechanical VRCs. This assembly is typically mounted at the top of the lift guide columns.



Drive chain	Drive chains on the F series mechanical VRC, through a series of a shaft and sprockets allow the carriage to be raised and lowered.
Drift	The action of a lift carriage slowly dropping, usually due to slight internal leaks in a hydraulic system or mechanical slippage of a motor brake.
EBVAC	An electrically powered bi-panel vertical acting gate.
Effective width/length	Refers to usable space for the materials load on the carriage, not the overall dimensions which includes space allowed for carriage side guards and snap chains.
Electrical cable	Electrical cables consist of at least two conductors contained within a protective outer cover.
Enclosure (lift guarding)	Structure surrounding a VRC to prevent outside interference with its normal operation and to safeguard personnel. Typically 8' (2438mm) high panels composed of expanded metal or other materials that will prevent a 2" (51mm) diameter ball from passing through (ASME B20.1 requirement).
Epoxy coating	Abrasion-resistant, two-part industrial-strength protective coating system applied over sandblasted and primed steel or direct to metal. The epoxy coating is ideal for outdoor, chemical, or caustic wash-down environments or applications where standard alkyd enamel is viewed as insufficient.
EVAC	An electrically powered single panel vertical acting gate.
Expanded metal (EM)	A sheet of metal uniformly slit and stretched, forming diamond-shaped openings in the metal sheet. Expanded metal is a one piece construction that will not unravel under normal circumstances and will hold its shape. Expanded metal comes in a standard (raised) or flattened diamond pattern in a variety of gauges, opening sizes, materials and sheet sizes.
Explosion proof (EXP)	Electrical devices (e.g., control panels, motors, limit switches) that are designed to operate safely in a specific location or area where potentially explosive environments can or do exist.
Floor-to-Floor distance	The distance from one operating floor level to the adjacent operating floor level (see Vertical travel).
Full Height Enclosures (FHE)	Structure surrounding the full height of a VRC to prevent outside interference with its normal operation and to safeguard personnel. Typically panels composed of expanded metal or other materials that will prevent a 2" (51mm) diameter ball from passing through (ASME B20.1 requirement).
Gate	A device that opens and closes manually or automatically to allow access to the carriage for loading and unloading. The gate is normally a swing, sliding, or vertical acting device constructed of similar expanded metal as the enclosure (see specific gate type).



General Arrangement (GA) drawing	The drawing produced by PFlow Industries, Inc. which shows the VRC lift, gates, and enclosures. The drawing may show but does not specify building details.
Guarded by location	Describes moving parts so protected by the parts remoteness from the floor, platform, walkway, or other working level, or by the parts location with reference to the frame, foundation, or structure to reduce the foreseeable risk of accidental contact by persons or objects. The parts remoteness from foreseeable, regular, or frequent presence of public or employed personnel may constitute guarding by location in reasonable circumstances. (See ASME B20.1 standard)
Guide angles	Guide angles are attached to the guide column to help capture and contain the guide wheels in the columns and guide the carriage.
Guide column	The structural members connected to the carriage that guide the carriage travel up and down.
Header	Header refers to the horizontal structure spanning the width of the carriage or gate. The carriage header defines the load height on straddle units.
HMI (Human Machine Interface)	The user interface in the control system that provides graphic control of the VRC. The HMI communicates with the programmable logic controller (PLC).
Hollow shaft	VRC mechanical shaft of the mechanical drivebase which penetrates the gear motor rather than coupling to the gear motor. This minimizes wear points.
Hydraulic cylinder	A device which converts fluid power into linear force and motion. The hydraulic cylinder usually consists of a movable element such as a piston and piston rod, plunger or ram, operating within a cylindrical bore.
Hydraulic power unit	Refers to motor, pump, and reservoir assembly. The reservoir is shipped with oil. Most hydraulic power units come with the control panel attached and pre-wired to the hydraulic pump.
Incoming voltage	The main voltage being supplied for operation of the equipment.
Interlock (Gate/Door)	An electro-mechanical locking system used on the gates or access doors of a VRC. The system prevents the VRC operation unless all such gates or access doors are closed. The system also prevents the opening of any such gate or access door unless the VRC carriage is present at that particular landing or opening.
Intermediate level	A floor level or levels between the uppermost and bottommost operating floor.
Junction box	An electrical control box used to join, centralize, and distribute wiring from different locations.
Keylock control	A keyed push button station that prevents unauthorized use of the VRC.
Kick plate	A curb on the outermost edge of the inoperable sides of the carriage deck which is designed to contain product and is a minimum of 4" (102mm) high.
Knock-down (KD)	Lift components shipped in two or more pieces. Typically field welding is required (e.g., KD carriage, KD headers, KD uprights, KD gates, etc.).



Landing	A permanent-working surface at a fixed elevation used for loading or unloading the carriage.
Lift chain	A chain that lifts the carriage and load.
Lift location light	Illuminated push button that indicates at which level the carriage is located.
Lifted load	The total weight that the VRC is designed to lift at a specific speed. Typically, this is the dead load plus live load (see Rated load).
Limit switch	An electrical device which is used to control the carriage position and monitor various mechanical devices.
Load pattern	<p>A method to describe the direction a load can be moved on and off a carriage at different operating floors or levels. These can be used in combinations.</p> <ul style="list-style-type: none"> ● “C” load pattern: Carriage configuration allowing a load/unload opening on one side of the carriage deck. ● “Z” load pattern: Carriage configuration allowing a load/unload opening on opposite sides of carriage deck. ● “90 degree” load pattern: Carriage configuration allowing a load/unload openings at right angles on the carriage deck.
Load test	The carriage is loaded to rated capacity, and the lift is operated.
Macropoxy	Macropoxy is a fast drying, polyamide epoxy designed to protect steel in industrial exposures. Ideal for protection of sharp edges, corners, and welds.
Mechanical stop	A mechanical means of stopping travel at a fixed position.
Momentary contact push button	A push button which only has to be pressed for an instant to activate the desired operation.
Non-operating end	The side(s) of a carriage not used for loading/unloading. Handrails or expanded metal sides and kick plate are normally supplied as minimum guarding.
Operating end	The side(s) of the carriage used for loading/unloading. At a minimum the side(s) are normally equipped with a safety chain as guarding.
Overall dimension	The outside dimension of the carriage structure or the entire lift.
Overtravel limit switch	A safety device provided on mechanical VRCs to stop carriage travel beyond the uppermost or lowermost floor level if the floor level positioning limit switch fails.
Photo eye	Photoelectric sensor that uses a focused beam of light to span the distance to a reflector. The VRC controls receive a signal when the reflected beam of light is detected by a sensor.
Pit	A depression in the floor a minimum of 1" (25mm) deeper than the carriage profile, which allows the carriage deck to be flush at operating floor or level.
Platform	The structure that forms the floor of the carriage and that directly supports the load (see Deck).
Pneumatic gate operator	A device that requires in-plant, clean and dry air to automatically open and close a gate. The device can be operated by either manually through the use of pull cords or push buttons, or automatically through the use of a PLC.



Pressure switch (hydraulic)	A sensor which detects hydraulic pressure. The sensor can be set to trip at a predetermined pressure. When this pressure setting is reached, the pressure switch will activate, opening the control circuit and stopping the pump motor.
Programmable Logic Controller (PLC)	A micro-processor based device that controls the VRC or Cartveyor™ through a resident software program.
Push-button (PB) station	The wall mounted, pedestal mounted, or hand held device used to control the operation of the VRC.
Qualified person	A person, who by possession of a recognized degree, certificate, professional standing, or skill, and who by knowledge, training and experience, has demonstrated the ability to deal with problems relating to the subject matter, the work, or the project.
Ramp	An access ramp used to load on and off of a carriage deck.
Rated load	The load the VRC is designed for and installed to lift at a rated speed (see Lifted load).
Reflector	A plastic, prismatic object used to reflect a beam of light emitted from a photoelectric sensor.
Roll-off panel	See Back-stop panel.
Roller chain	The type of chain drive most commonly used for transmission of mechanical power. The roller chain consists of a series of short cylindrical rollers held together by side links and connecting pins. The roller chain is driven by a toothed wheel called a sprocket.
Safety cam	Spring-loaded, hardened steel cam directly attached to the lift chain or gate chain that engages if the lift chain or gate chain breaks or slackens, preventing the carriage or gate panel from dropping more than a few inches.
Side guards	A protective enclosure on the outermost edge of the inoperable sides of the deck welded to the carriage to contain load. Can be rails, sheet steel, or expanded metal.
Slack chain device	A device that monitors a chain and trips if the chain goes slack. If the chain becomes slack or breaks, the limit switch mounted on the slack chain device will trip and remove power to the circuit.



Spliced guide column	Guide column that is fabricated and delivered in two or more sections necessitated by manufacturing, handling, or installation constraints.
Sprocket	A wheel typically mounted on a shaft. The wheel has a row of teeth around its edge that fit into the links of a chain.
Straddle	A style of VRC where the carriage rides between two guide columns that are located on opposite sides of the carriage. This style of lift will accommodate “C” and “Z” type loading patterns.
Top of roller (TOR)	Top elevation of a horizontal conveyor system roller which is also the lower elevation of the load.
Touchscreen	See HMI.
Transom	A panel or panels used to close an enclosure opening above the VRC entrance.
Travel	The difference in elevation between the bottommost level of the carriage platform and the uppermost level of the carriage platform, regardless of whether the carriage is pit or floor mounted.
UHMW (Ultra-High Molecular Weight)	An abrasion-resistant, high-impact, polyethylene material used throughout the VRC to protect and/or guide moving parts.
Uprights	The portion of the carriage that houses the wheels that guide the carriage between the columns.
VAC	A single panel vertical acting gate.
VFD (Variable-Frequency Drive)	A VFD is a type of drive used in electro-mechanical drive systems to control AC motor speed and torque by varying the motor frequency and voltage.
Velocity fuse	A device that senses hydraulic flow across a control orifice when the pressure differential exceeds a predetermined amount. A spring-biased poppet closes, shutting flow to the damaged hydraulic circuit and prevents the lift carriage from descending.
Vertical travel	Distance the carriage deck travels; floor-to-floor or total distance (see Travel).
Vertical Reciprocating Conveyor (VRC)	A reciprocating power actuated lifting device (not designed to carry passengers or an operator) that receives loads on a carriage and transports these objects from one operating elevation to another.
VRC specification sheet	PFlow Industries, Inc. informational data sheet providing general information on a specific VRC.
Wheelblock assembly	Sub-assembly fastened to the carriage upright that contains the guide roller elements and safety cam for the chain driven VRC lift. The lift chain is typically attached to the wheelblock assembly safety cam.



Gate Types:

Single swing gate

This type of gate hinges on one side and latches on the other, may be either right or left-hand swing. Clear space is required in front of the VRC for the gate to swing open.

Bi-parting swing gate

The bi-parting, swing gate has hinges on each side and latches in the center. Clear space is required in front of the VRC for the gates to swing open.

Single panel vertical acting gate (VAC)

The VAC gate panel closes to the floor and opens in the upward direction.

Double panel vertical acting gate (BVAC)

The BVAC gate is the same as the single panel VAC above in operation and use except the two (2) panels telescope from a nested position.

Horizontal sliding gate

The horizontal sliding gate operates in the same manner as a vertical acting gate except the gate functions in the horizontal direction.

Roll-up door

The roll-up door can be anything from an industrial type roll-up steel door to self-storage facility type door.

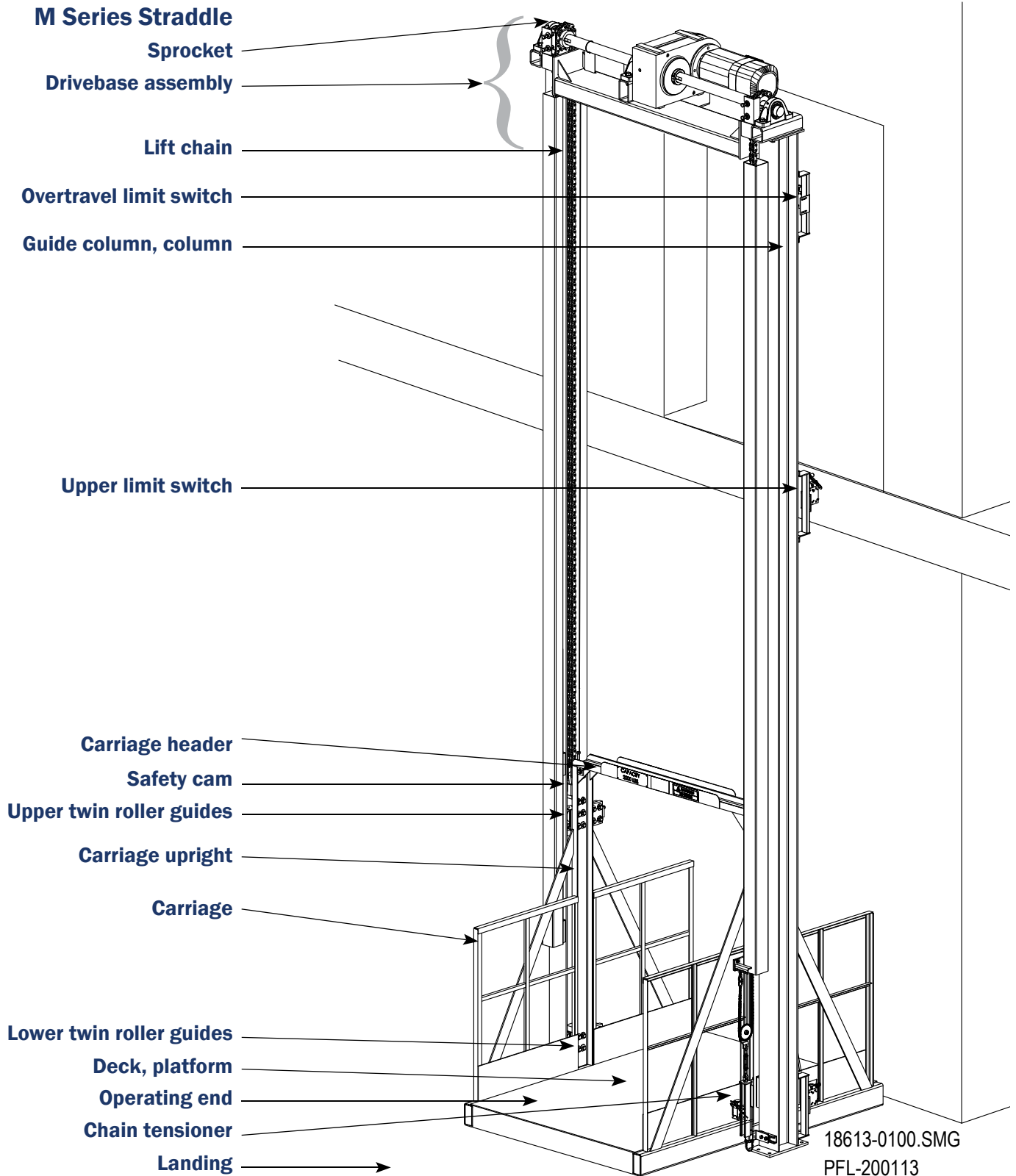

**M Series
Cantilever**

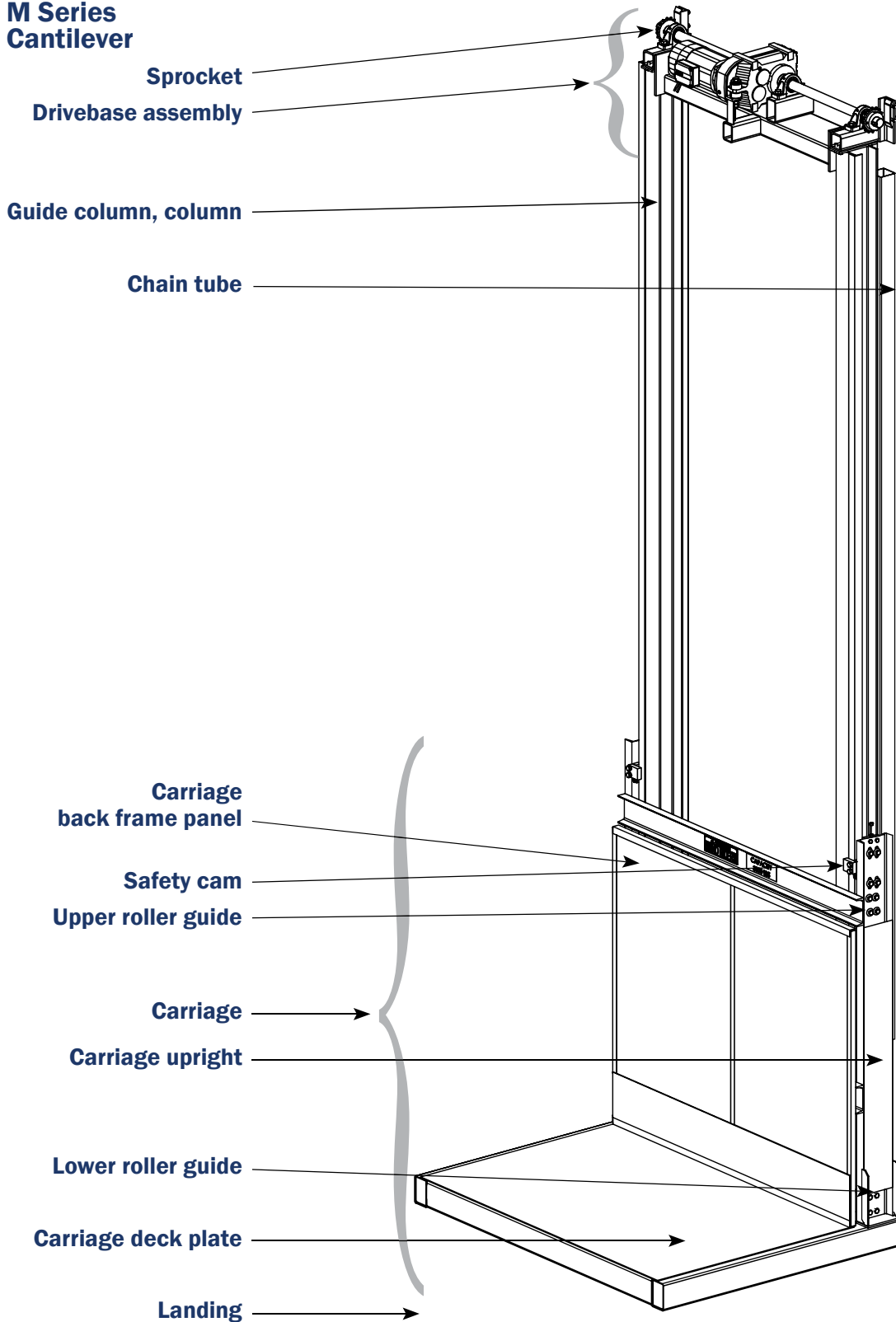

PFL-200520-1

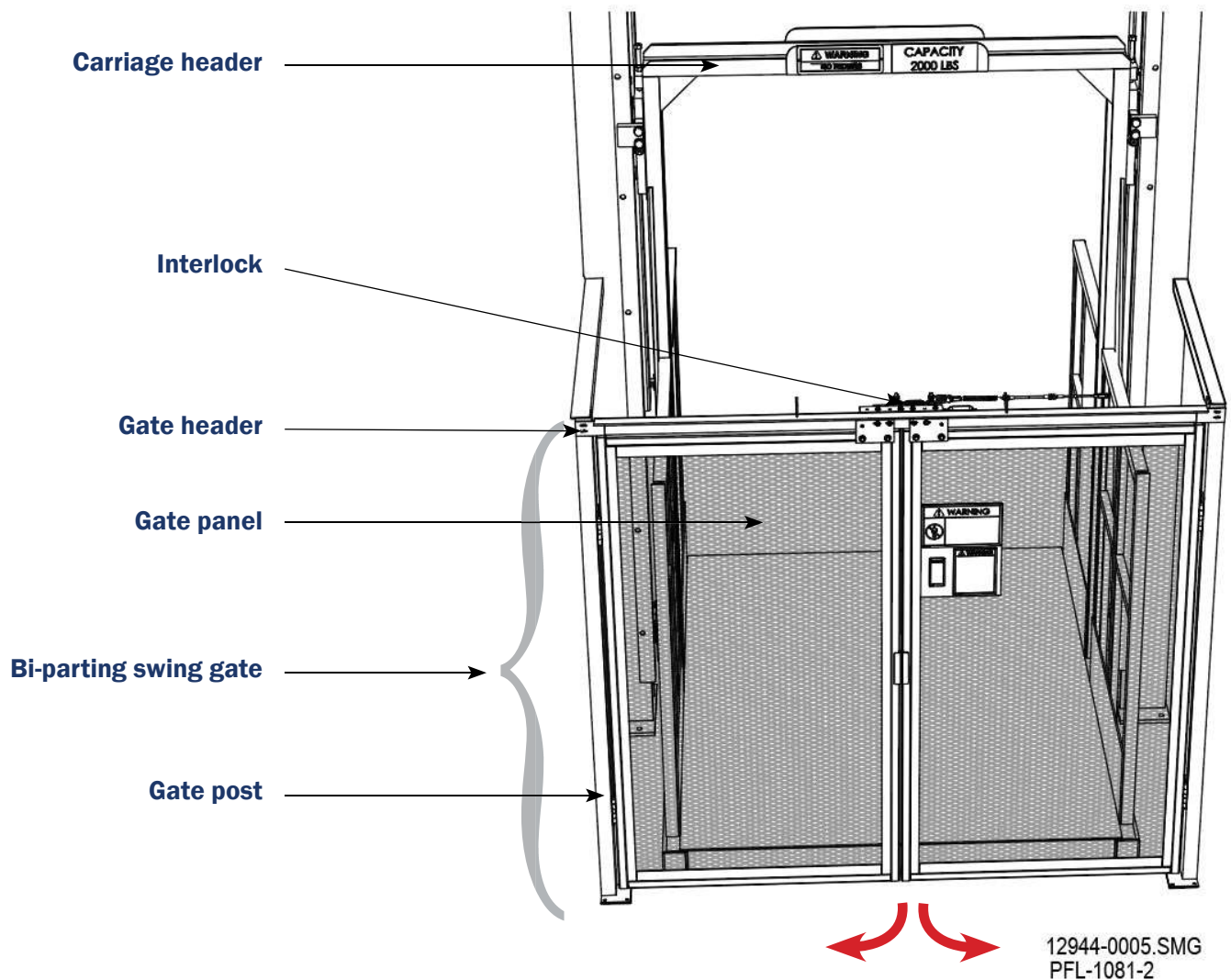
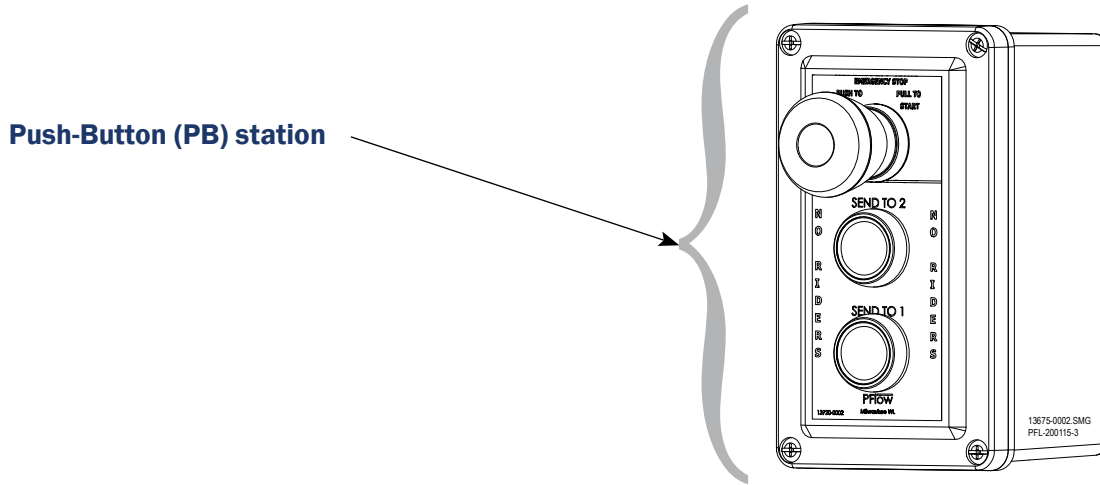





Field Electrical Wiring Standards

All electrical wiring and craftsmanship completed in the field shall be in accordance with existing state, local and National Electrical Code (NEC) standards.

Definitions

In-field electrical wiring

All hard wiring of all electrical devices external of control panel.

Control circuit

The control circuit refers to all circuits and devices at 120 VAC and below.

Power circuit

Power circuit refers to all circuits and devices at 208 VAC and above.

Systems

Systems refers to automated vertical and horizontal conveyors.

Requirements

1. It is recommended that all control circuit wiring is #14 AWG, copper, stranded, type THHN or equal, 600 VAC.
2. It is required that all power circuit wiring is #12 AWG minimum (sized appropriately for the load), copper, stranded, type THHN or equal. A green grounding wire shall be provided to power devices.
3. Per NFPA 79, the colors of individual conductors shall be:

Power wiring - Black	24 VAC neutral - White
115 VAC - Red	24 VDC - Blue
115 VAC neutral - White	0VDC - White/blue
24 VAC - Red/black	Ground - Green or green/yellow

Note: These colors only apply to individual conductors. These colors do not apply to prefabricated cables.

4. All wires must be labeled on each end with the wire number from the electrical drawing using a machine or computer generated label, utilizing black characters on a white background.
5. All field devices must be individually terminated in the control panel.
6. Screw on solderless connectors (wire nuts) shall be of the insulated type, spring lock, and of the proper size to accommodate wires.
7. Terminal lugs shall be of the insulated type, crimp style, and of the proper size to accommodate wire(s) and terminal fasteners.
8. Conduit and related hardware shall conform to local, state, and NEC standards. The minimum size shall be 1/2". Connectors and couplings shall be appropriate for conduit type.
9. Flexible conduit shall be a minimum of 1/2", shall be of the liquid-tight type, and shall be installed with compatible liquid-tight connectors.
10. The customer shall locate and install a fused disconnect switch within the line of sight of the control panel. The customer shall ensure accessibility to the disconnect switch with regard to existing electrical codes and standards.
11. Control wiring and conduit shall be separate from the power wiring and conduit.
12. When mounting resistor banks, make sure the resistor elements are horizontally positioned.
13. Drop cords (flexible cords) shall be multi-conductor festoon-type cable where applicable.

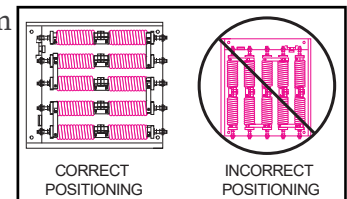

Resistor Bank Positioning



Electrical Ruling Bodies

-
- NEMA** *National Electrical Manufacturers Association* provides national testing and manufacturing standards body of electrical apparatus.
-
- UL** *Underwriters Laboratories, Inc.* is an independent testing laboratory. Many local codes require UL control panels and electrical apparatus.
-
- JIC** *Joint Industry Council* is an advisory group that provides standards for production equipment, safety, and dependability.
-
- NFPA** *National Fire Protection Association* is the ruling board of NEC and sets national fire and safety standards for equipment and manufacturing facilities.
-
- CSA** *Canadian Standards Association* is a regulatory agency of Canada.
-
- ANSI** *American National Standards Institute* oversees the creation, promulgation, and use of thousands of norms and guidelines that directly impact businesses.
-
- ASME** *American Society of Mechanical Engineers* is a leader in technical innovation with a focus on advancing and applying engineering knowledge and communicating the excitement of engineering. This group is the Secretariat for ANSI.
-
- NEC** *National Electrical Code* is an advisory board to NFPA with recommendations and codes usually adopted throughout the United States.
-

PFlow's Standard

NEMA 12 classification is to be used in a general purpose, indoor only application.

All PFlow Industries, Inc. control systems are built to a NEMA 12 minimum classification. All PFlow Industries, Inc. control systems conform to the following standards:

- **NFPA 70 (NEC):** The National Electrical Code.
 - **NFPA 79:** Electrical standard for industrial machinery.
-

Outdoor Application

Outdoor equipment or electrical devices exposed to severe weather conditions should not be rated less than NEMA type 4. This is a watertight, dust-tight, indoor-outdoor classification that will provide protection against splashing water, seepage of water, falling or hose-directed water, and severe external condensation.

Corrosive Application

The chemical industry on the whole usually specifies a minimum NEMA type 4X. A NEMA 4X rating is similar to a NEMA 4 with added corrosion resistance.



**PFlow's Standard
(continued)**

Hazardous Location

Hazardous locations are an extremely specialized electrical classification. Few electrical experts exist in this field. All hazardous locations must be handled as defined by the class, division, and group designator for the job site condition.

The NEC has three classes (I, II, III), - two divisions, (1 and 2) and seven group designations (A, B, C, D, E, F, and G).

Class Definitions

Class I locations: Locations in which flammable gases, flammable liquid-produced vapors, or combustible liquid-produced vapors are or may be present in the air in quantities sufficient to produce explosive or ignitable mixtures.

Class II locations: Locations that are hazardous because of the presence of combustible dust.

Class III locations: Locations that are hazardous because of the presence of easily ignitable fibers or where materials producing combustible flyings are handled, manufactured, or used, but in which such fibers/flyings are not likely to be in suspension in the air in quantities sufficient to produce ignitable mixture.

Division Definitions

Division 1 is an extremely dangerous explosive condition that exists normally.

Division 2 is a dangerous explosive condition that could exist but usually does not.

Group Designations

Group designations are given by the NFPA, State Fire Marshals, insurance companies or consulting engineering firms according to the gasses, dust, or other particles in the area and the spark or temperature needed to produce an explosion.

Section 6 | Electrical Standards and Definitions



MATERIAL HANDLING SOLUTIONS

www.pflow.com
P 414 352 9000
F 414 352 9002
6720 N. Teutonia Ave.
Milwaukee, WI 53209



Mechanical Overview

Each M series (mechanical) Vertical Reciprocating Conveyor (VRC) consist of two (2) columns, a drivebase assembly with a gearmotor reducer, drive shaft with two (2) lift sprocket assemblies, a moving carriage deck, and if furnished, interlocked safety gates or doors. In addition, a main control panel and typically at least one push-button station per level are furnished. For more information on the electrical components, see Section 8 in this manual.

Lift Columns

The M series consists of two (2) vertical upright columns. These are anchored to the floor at the lower floor level, positioned by the drivebase at the top, and braced to the building structure at the upper and intermediate levels.

Each column has a guide angle welded to one flange of the column to form a track. A chain tube guard is welded to the face of the other flange.

Straddle / Cantilever Configuration

There are two (2) configuration types available for this model. “Straddle” has a column located on each side of the carriage. The guide angles face each other allowing the carriage to ride between them. See Figure 7-1. “Cantilever” has both columns located at the back of the carriage. See Figure 7-2. There is no difference in the operation or maintenance between these models.

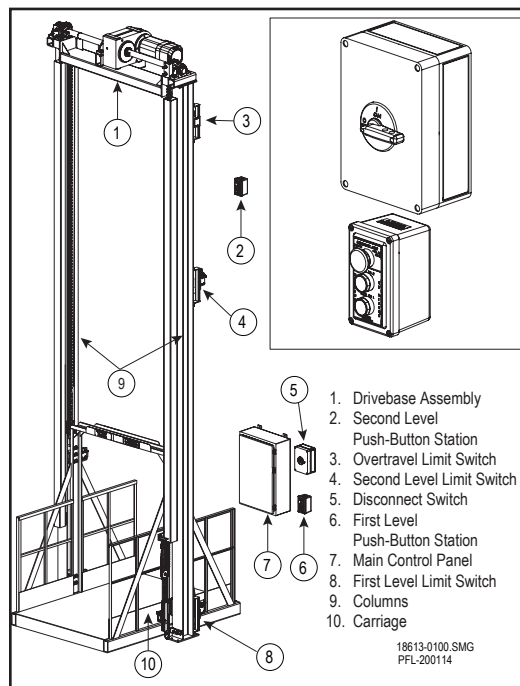

Straddle Orientation Figure 7-1

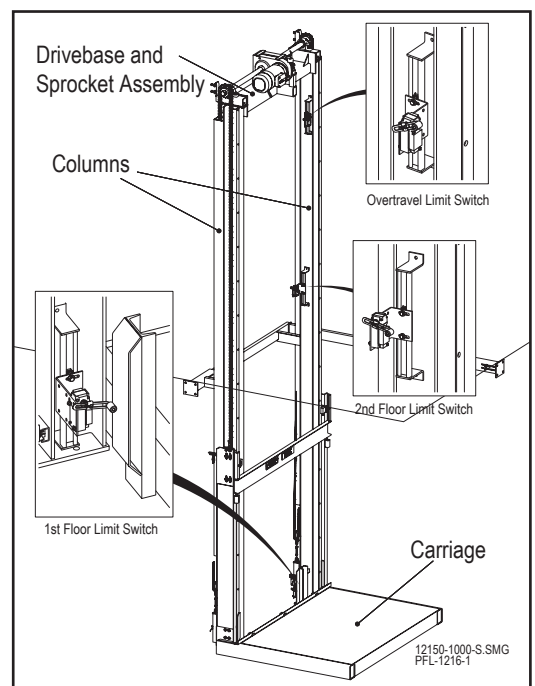

Cantilever Orientation Figure 7-2

Drivebase Assembly

The drivebase assembly consists of a motor, brake, gearmotor reducer (commonly referred to as a gear motor assembly), lift sprockets, a drive shaft, bearings, and a support structure. Roller lift chains connect to tensioner chains and chain tensioners complete the components. See Figure 7-3 and Figure 7-4.

Inside each column, one end of a lift chain connects to a safety cam assembly which is bolted to the carriage upright.

The lift chain goes up and over the lift sprocket at the top of the column drivebase assembly, then proceeds downward through the chain guard (chain tube), and connects to the smaller tensioner chain.

The tensioner chain then travels around the small chain tensioner sprocket and back up to the carriage to fasten to a chain tensioner bracket (shown in Figure 7-4, Item 5).

The tensioner sprocket is spring-loaded by the chain tensioner which maintains tension on the chain/tensioner combination. If the lift chain is pulled too tight or becomes slack, the chain tensioner limit switch is activated to shut off power to the VRC.

The chain tensioner is adjusted at a turnbuckle on the chain tensioner assembly.

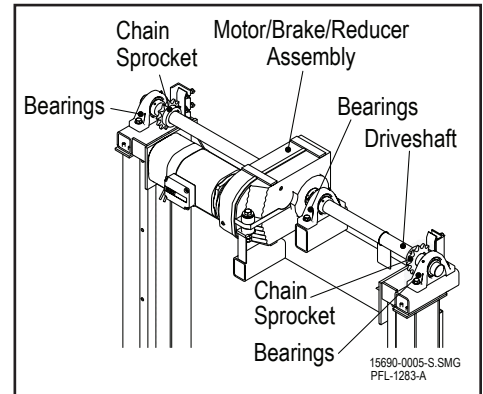

Drivebase Assembly Figure 7-3

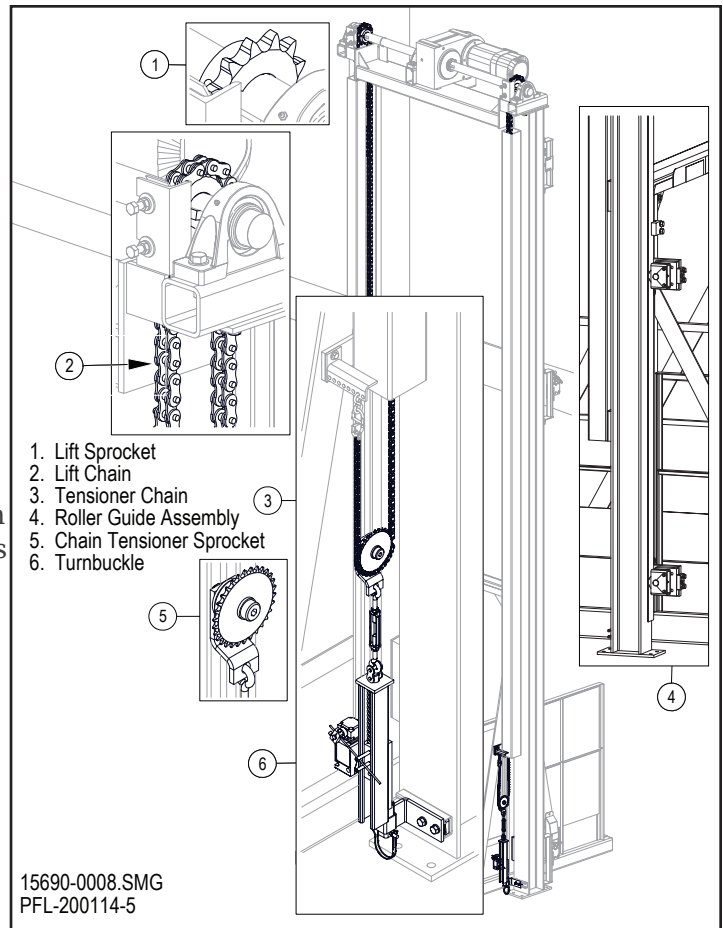

Lift Chain Tensioner Assembly Figure 7-4

NOTICE This VRC uses special high strength chain. Do not use standard ANSI roller chain or connecting links as a replacement. Contact PFlow Industries, Inc. Customer Support Department for the required chain specification.

Safety Cam and Roller Guides

Two (2) safety cam assemblies are bolted to the carriage uprights and reside inside the column. **Straddles** have four (4) twin roller guide assemblies bolted to the carriage (two on each side) with one wheel riding within the column and the other wheel riding on the outside of the column. See Figure 7-5 and Figure 7-6. **Cantilevers** have four (4) single roller guide assemblies bolted to the carriage (two on each side) with the wheel riding within the column. See Figure 7-7 and Figure 7-8.

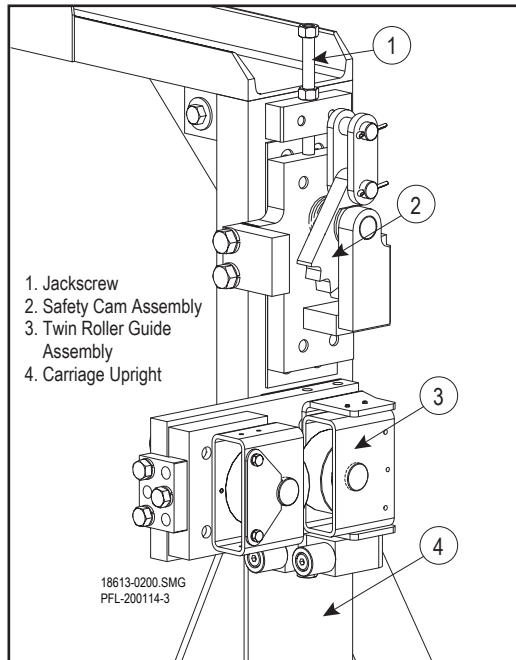

Straddle - Safety Cam and Twin Roller Guide Location
 Figure 7-5

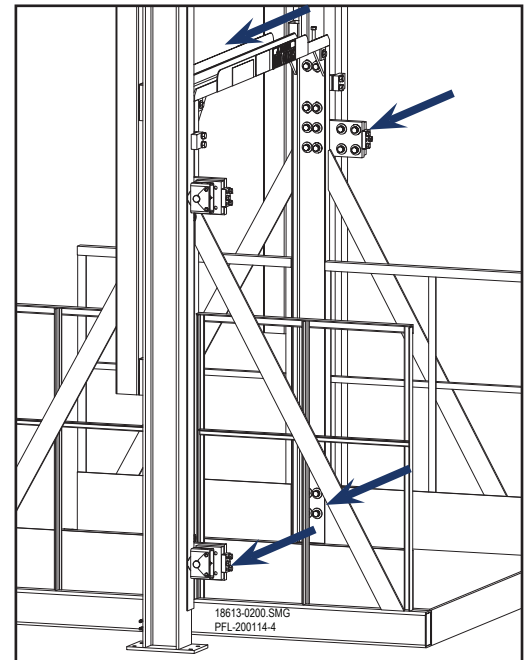

Straddle - Twin Roller Guide Locations
 Figure 7-6

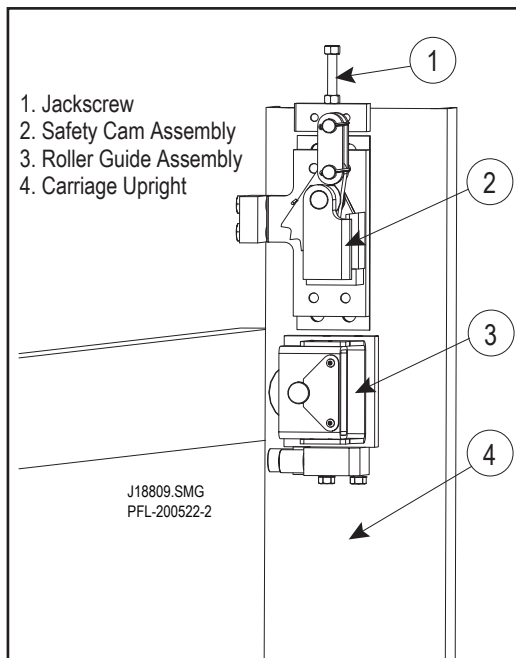

Cantilever - Safety Cam and Roller Guide Location
 Figure 7-7

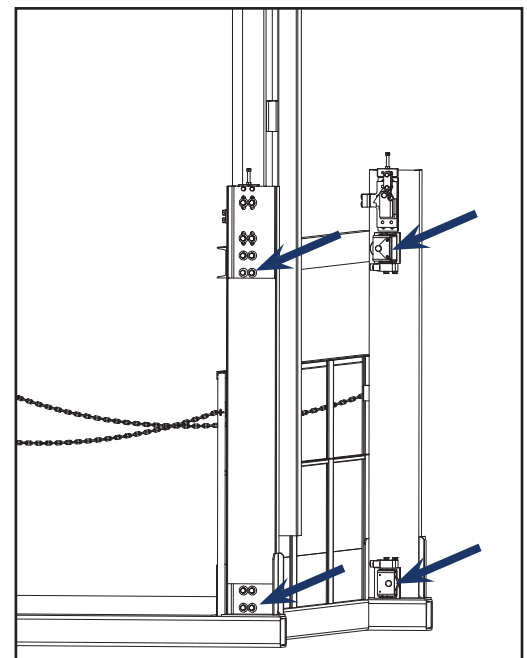

Cantilever - Roller Guide Locations
 Figure 7-8

Safety Cam Function

If the lift chain breaks or becomes slack, the safety cam will pivot into a jam position with the column guide angle to stop the carriage from falling. The safety cam shoe on the outside of the guide angle track helps wedge the safety cam teeth. See Figure 7-9 and Figure 7-10.

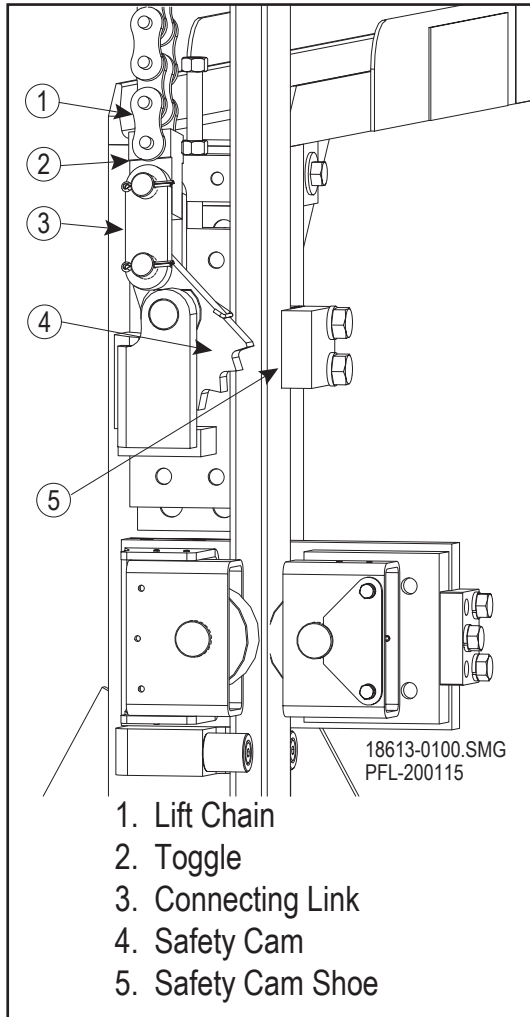

Safety Cam Disengaged Figure 7-9

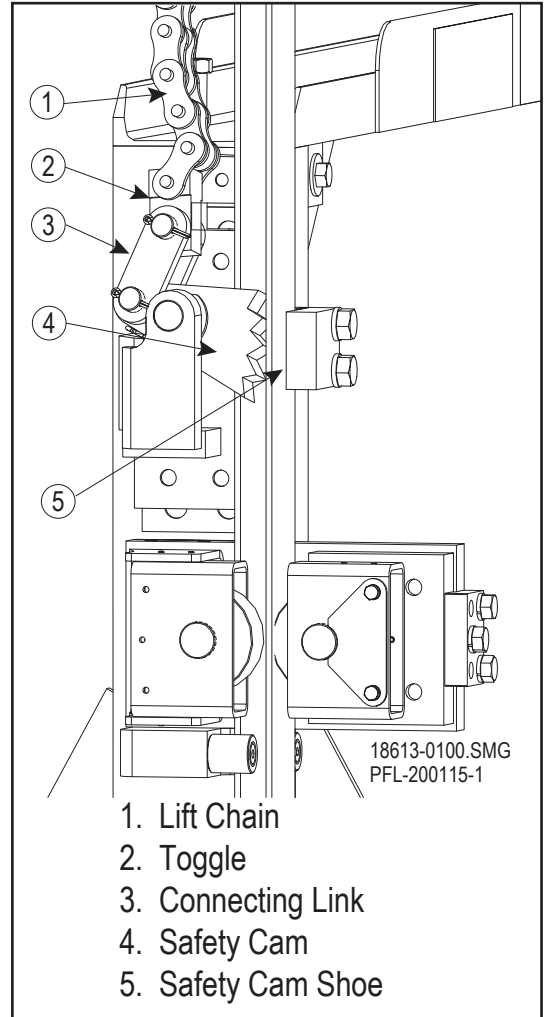

Safety Cam Engaged Figure 7-10



Enclosures

In accordance with ASME B20.1, Section I-3.9, PFlow Industries, Inc. supplies standard 8' (2,438 m) tall enclosure panels to be installed around the Vertical Reciprocating Conveyor (VRC) as required by site conditions. The enclosure panels are steel with 1-1/2" (38mm) angle frame and 16 gauge flattened expanded metal designed to reject a ball 2" (51mm) in diameter. PFlow Industries, Inc. standard enclosure panels are typically 8' tall (2,438 m). Full height enclosures (FHE) are furnished when designed for site specific requirements. See Figure 7-11.

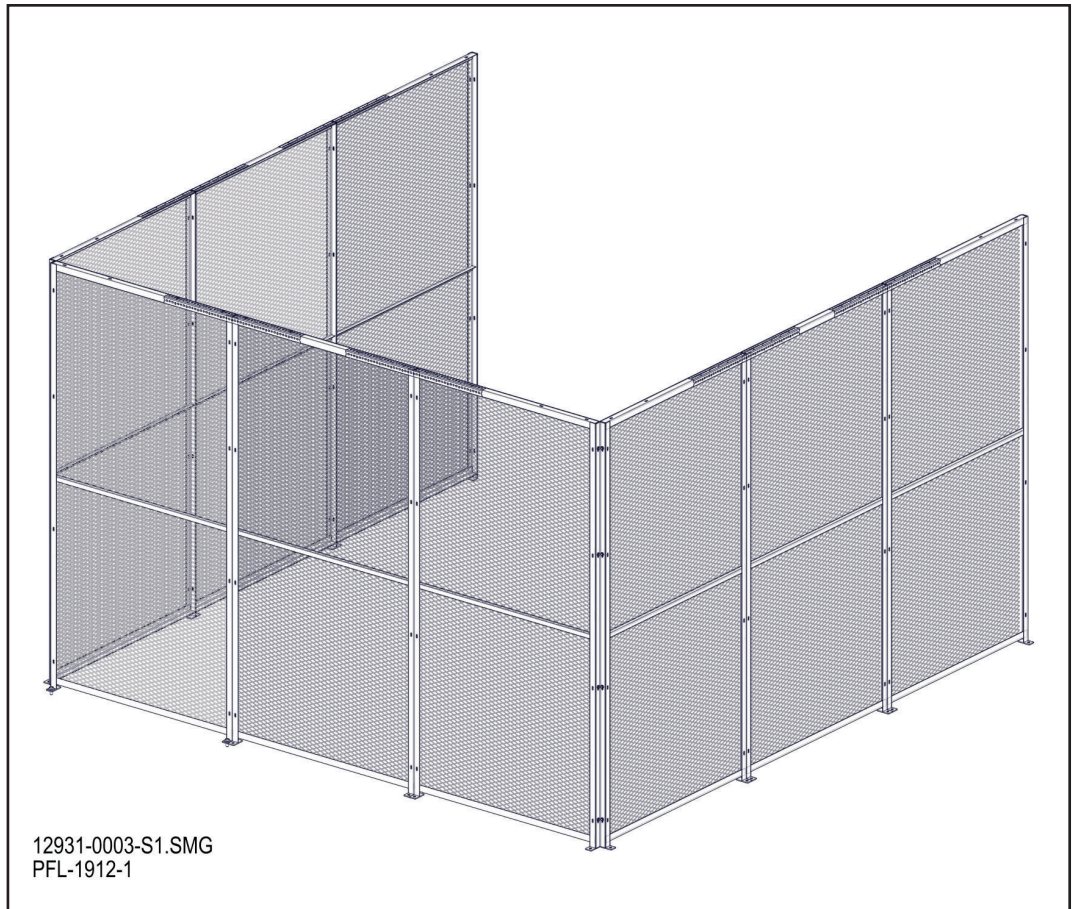

Floor Level Enclosures Figure 7-11

Gate Assemblies

A safety gate assembly or door is provided at each level opening accessing in the lift area. All gates and/or doors accessing the lift area are electromechanically interlocked. When a gate or door is open the interlock prevents movement of the carriage away from the respective level. When the carriage is not present at a level, opening the gate or door is prevented by the mechanical interlock. See Figure 7-12.

PFlow Industries, Inc. offers various styles of interlocks depending upon the gate type and application.

The parts section of this manual contains views with part numbers.

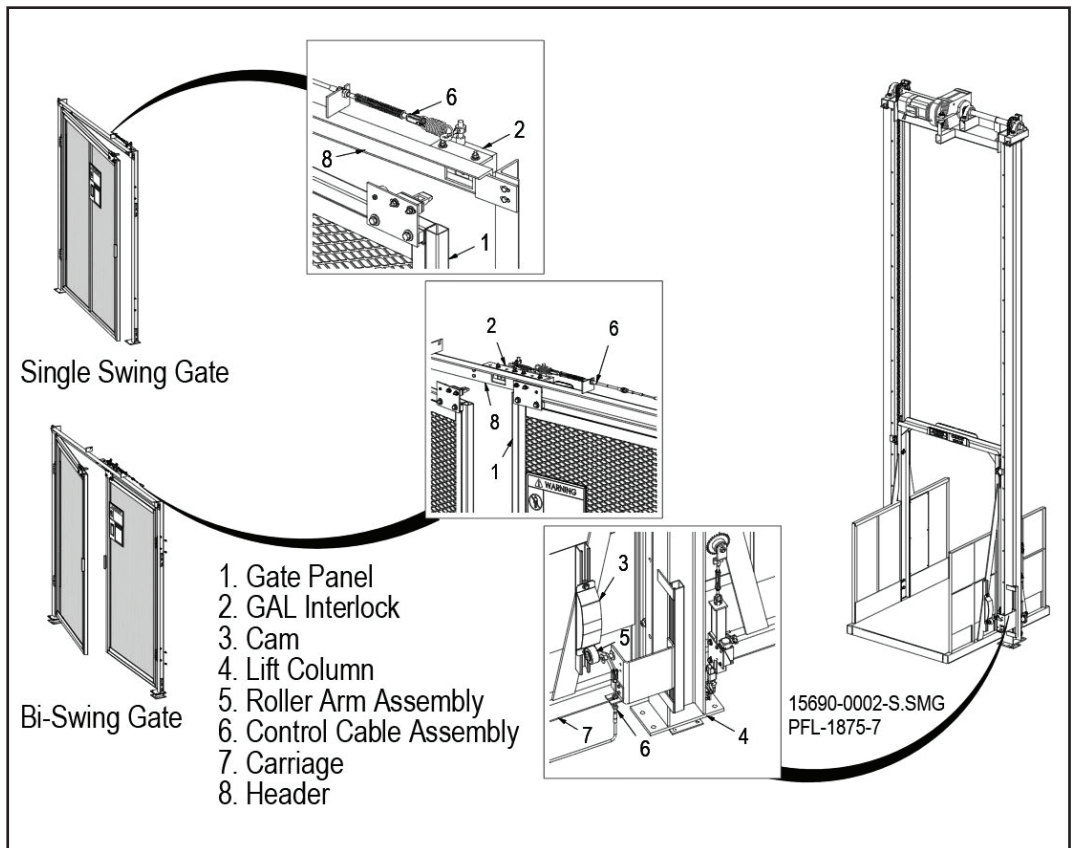

Swing Gate Interlock Examples
 Figure 7-12

Examples

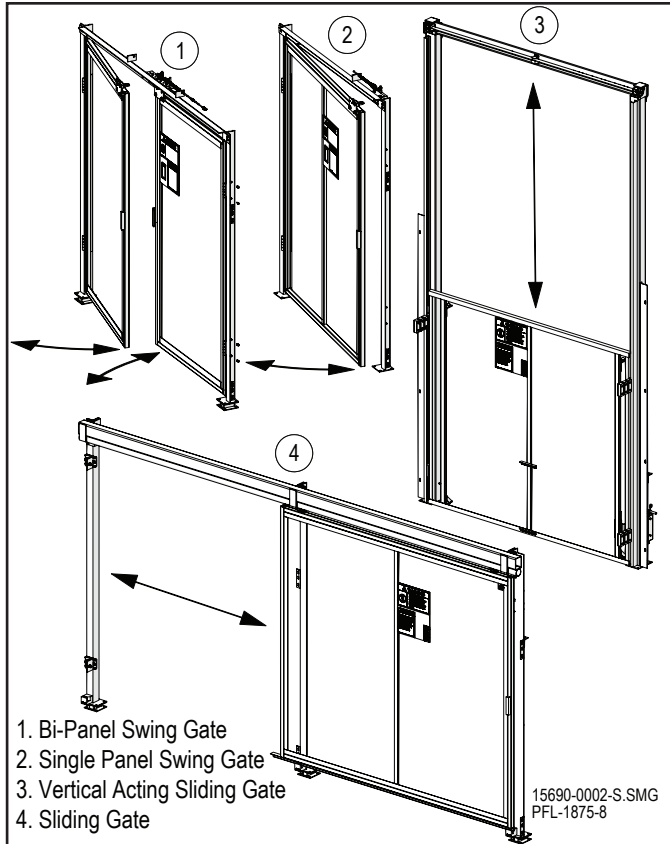

Swing Gate Interlock Examples Figure 7-13

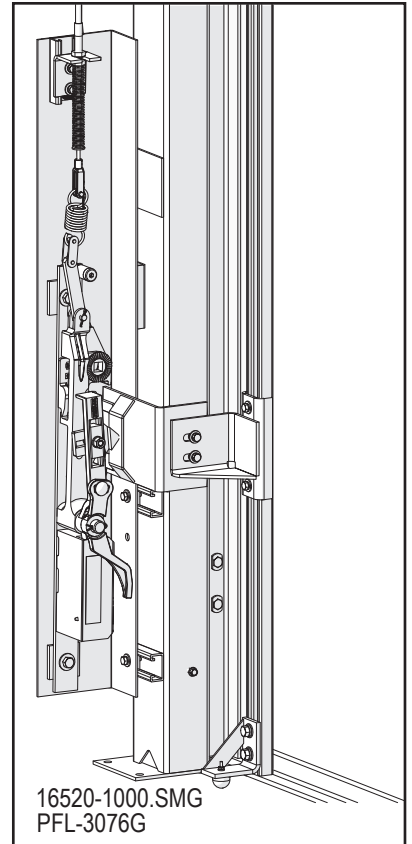

Peelle - VAC Figure 7-14

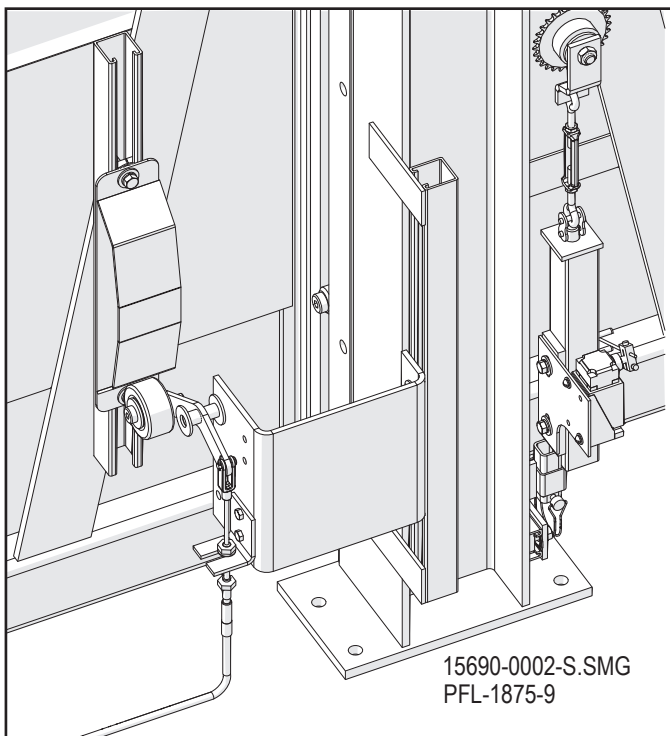

Cable Actuator Figure 7-15

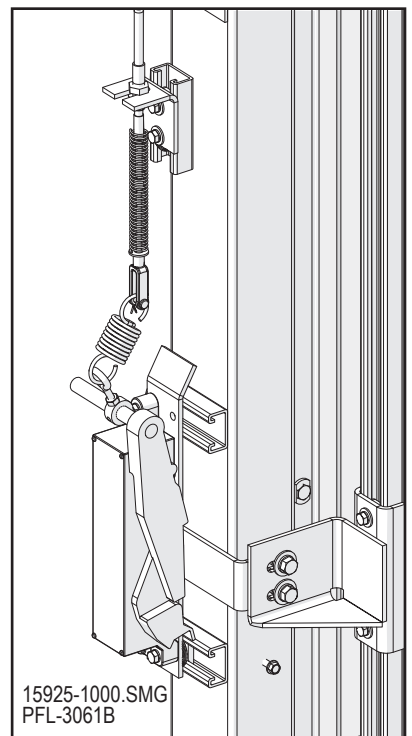

Anderson - VAC Figure 7-16





Electrical Overview

The following is a standard description of the electrical wiring of an M series VRC. This does not include any specifics on options available or ordered (e.g., gates, DeckLocks, photo eyes) A copy of the electrical schematic can be found in the control panel and the shipping packet originally included in the parts crate.

WARNING

Falling hazard! Make sure all safety devices are in place and operable before using the equipment. If any safety device is missing or inoperable, immediately remove the equipment from service.

Per ASME B20, all gates or doors accessing the lift area must be electro-mechanically interlocked. This requires electrical contacts to prevent the lift from operating if a gate is open when the carriage is at the level and mechanical locks to lock the gate until the carriage is at that level.

NOTE

Different gate interlock types and styles are supplied depending upon the gate type and site conditions. Standard gate styles can incorporate one to four electrical components per gate.

Main Control Panel

All electrical devices are connected individually to the main control panel. The main control panel contains a fused transformer, motor starter, relays, etc. A motor overload and current sensor is provided to protect the motor from excessive current draw.

Push-Button Stations

One station is normally supplied for each level. ASME B20.1 code requires that the push-button stations be remotely located and unable to be activated by someone standing on the carriage. Each push-button station contains Send to “x” push-buttons and an emergency stop (E-stop).

The Send to “x” push-buttons are momentary contact. This means the operator can press and release the Send to “x” push-button and the carriage will travel to the selected level. The operator does not need to hold the Send to “x” push-button for the carriage to continue moving. When pressed, the emergency stop prevents the carriage from moving. The emergency stop must be pulled out before carriage movement can be initiated again.

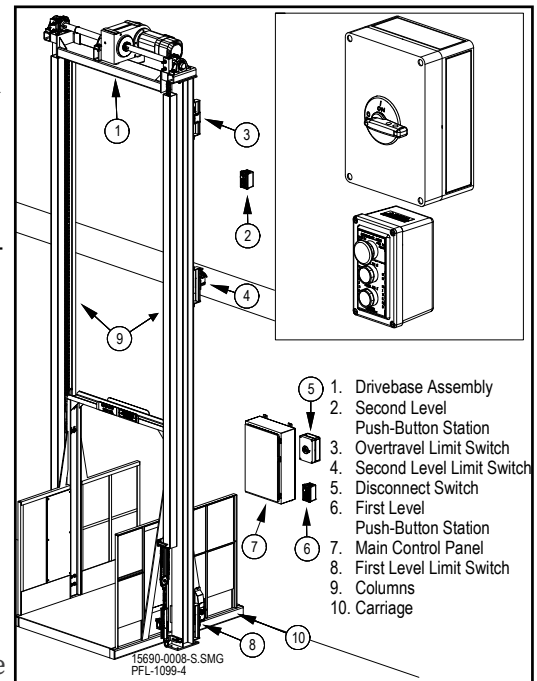

Electrical Components Figure 8-1

Main Disconnect Switch

As required by NEC code, the main disconnect switch must be fused, lockable, and located within line of sight of the control panel and no more than 6' 6" (1,981 m) off the floor.



Drivebase Assembly

The motor / brake is located on the drivebase assembly. The motor and brake wiring must be verified prior to energizing the VRC.

Limit Switches

The M series VRC has five (5) limit switches incorporated into a standard two-level VRC: one (1) at each level to stop the carriage, one (1) overtravel, and two (2) chain tensioner switches. All limit switches require field mounting and wiring. VRCs servicing more than two levels require two (2) additional limit switches for each intermediate level.



Before You Begin

Read this entire manual before operating the Vertical Reciprocating Conveyor (VRC).

Service must be performed by qualified and trained service technicians only.

NOTICE

A qualified person is defined as a person who, by possession of a recognized degree or certificate of professional standing, or by extensive knowledge, training, and experience, has successfully demonstrated his/her ability to solve problems relating to the subject matter and work.

Personnel to carry out work on the VRC must exclusively be qualified personnel who - based upon their education, experience, instructions as well as knowledge concerning relevant standards and provisions, accident prevention, regulations and operating conditions - have been authorized by the person being responsible for safety, to carry out the activities described in these instructions and who - when doing so - are in a position to recognize possible risks early and to avoid them.

DANGER



- Stay within the rated lift capacity.
- Make sure all safety devices are in place and operable before using the equipment. If any safety device is missing or inoperable, immediately remove the equipment from service.
- Falling Hazard! Close all gates before the carriage is moved. Never leave the lift unattended with the gates in the open position. Never close gates when a person is on the carriage or within the fenced area.
- Keep clear of unsupported platforms. Stay out of the area under a raised platform. If a maintenance operation requires the carriage to remain in the raised position, refer to Bulletin 15709-0083 for additional information or contact PFlow Industries, Inc. Customer Support Department for assistance.

WARNING



- This equipment can be dangerous if not used properly. Allow only competent adults who have been properly trained and authorized personnel to operate this equipment.
- Passengers are not permitted. Riding may result in death or serious personal injury.
- This equipment can be dangerous if not used properly. Allow only competent adults who have been properly trained and authorized personnel to operate this equipment.
- Avoid Shifting Loads! Place the load in the center of the carriage platform to avoid shifting loads. Lock rolling casters in place. Make sure that any portion of the load does not overhang the perimeter of the carriage. Prevent unstable load conditions.



- Entanglement hazard! Secure long hair, wear snug-fitting clothing, and avoid wearing jewelry while using the VRC.

Begin Sequence

1. Press the desired floor level button. See Figure 9-1. The coil in the motor starter magnetically closes the high voltage contacts and the power circuit to the motor starter. See Figure 9-2. This action turns the motor in the needed direction.
2. The brake is released. The motor turns the gears in the reducer, which in turn rotates the keyed drive shaft. The drive sprockets on the shaft turn resulting in the raising or lowering of the lift chains. The lift chains are fastened to carriage wheelblocks, which are bolted to the carriage uprights. Adjustments to the wheelblock levels the carriage deck.
3. When the carriage arrives at the next level, the floor level limit switch is activated by a carriage mounted cam. See Figure 9-3. When the floor limit switch is activated, the switch cuts the power to the motor circuit. The motor starter contacts open, the motor stops, and the brake is applied. This stops and holds the carriage position.

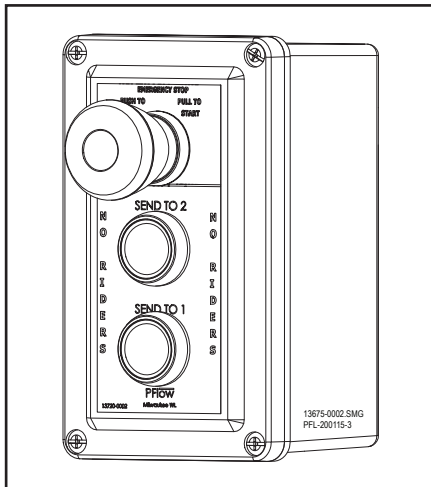

Push-Button Station Figure 9-1

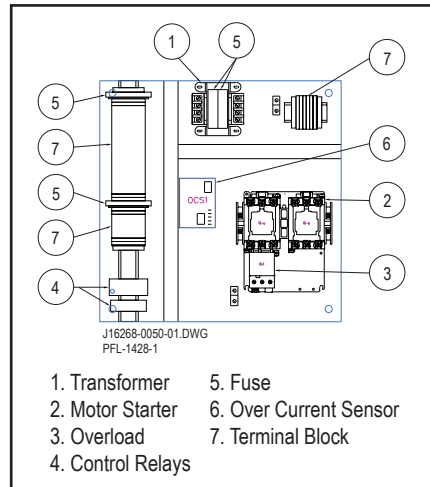

- | | |
|-------------------|------------------------|
| 1. Transformer | 5. Fuse |
| 2. Motor Starter | 6. Over Current Sensor |
| 3. Overload | 7. Terminal Block |
| 4. Control Relays | |

Control Panel Example Figure 9-2

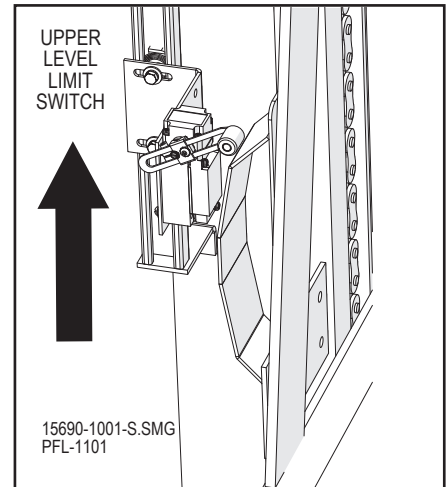

Limit Switch / Cam Figure 9-3

**Sequence
(continued)**

- The carriage overtravel limit switch is a safety device mounted on the column above the uppermost floor level limit switch. In the event of failure to activate the uppermost floor level limit switch, the overtravel limit switch is activated when it comes into contact with the carriage mounted wheelblock shoe on the side of the carriage. The switch cuts the power to the motor circuit. The motor starter contacts open, the motor stops, and the brake is applied. This stops and holds the carriage position. If the uppermost floor level limit switch fails, have a qualified electrical controls technician investigate why and correct the problem before reactivating the VRC. See Figure 9-4.

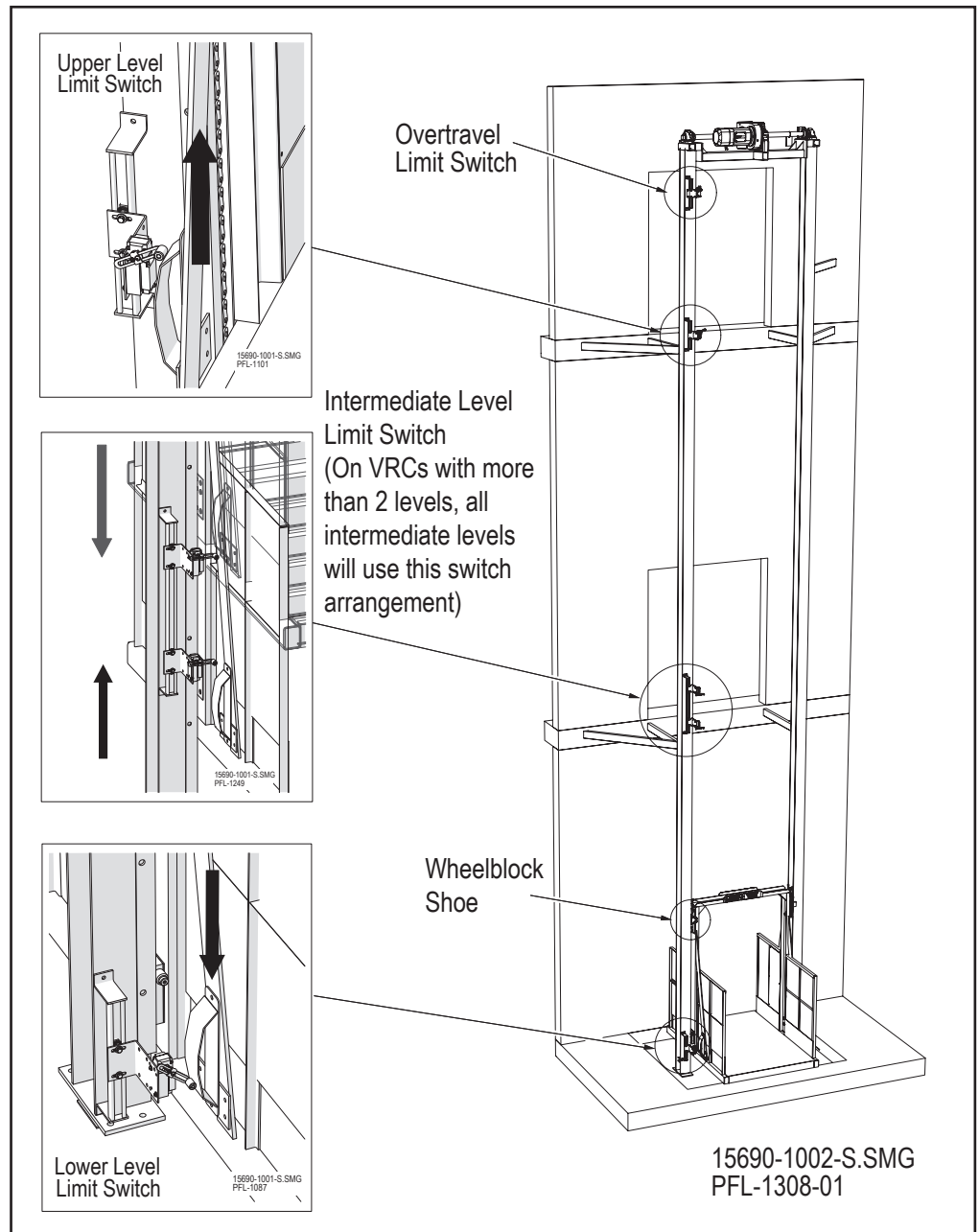

Limit Switch Figure 9-4

**Sequence
 (continued)**

5. If there is excessive motor current draw that can cause motor overheating, the overcurrent sensor (OCS) in the control panel protects the lift motor by cutting off the power to the control circuit. This happens when the carriage is loaded beyond its rated capacity. See Section 15 for more information.
6. The chain tensioner limit switch is typically mounted at the bottom of the lift column. If a lift chain becomes slack or is broken, the chain tensioner limit switch activates to shut off power to the motor and apply the brake. The safety cam rotates and sets on the column. The carriage stops. The VRC will not operate until the lift chain is repaired and the chain tensioner readjusted. See Figure 9-5.

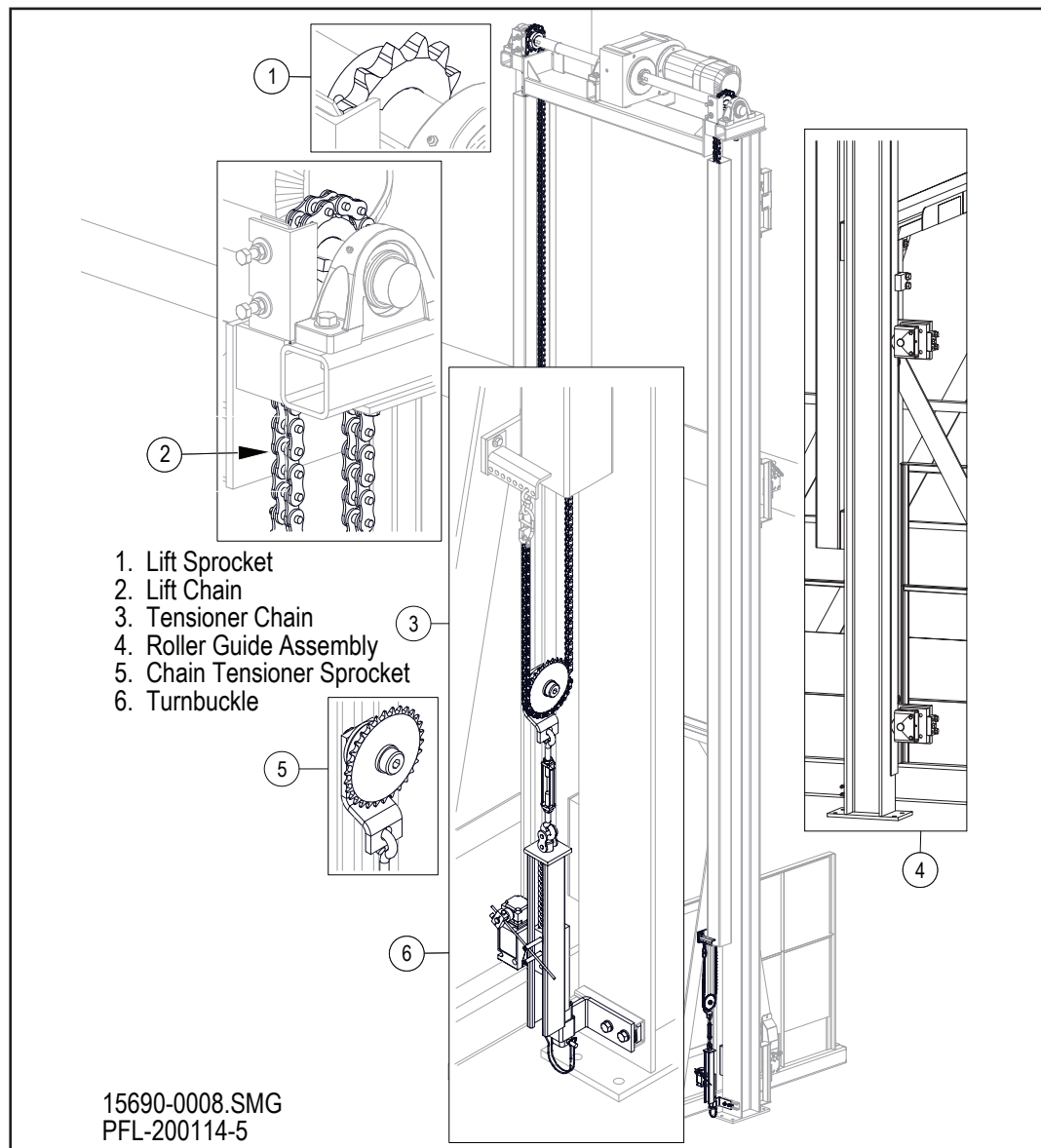

Lift Chain Tensioner
 Figure 9-5

To Operate the VRC

1. Close all gates and make sure the gate latches are engaged.
2. Press the desired floor level button to move the carriage to the desired floor. The carriage stops when the appropriate level is reached.
3. When the carriage arrives at the appropriate level and comes to a complete stop, open the gate.
4. If an emergency occurs while the carriage is moving, push the emergency stop (E-stop) button. The VRC is inoperable until the E-stop button is pulled out. See Figure 9-6.

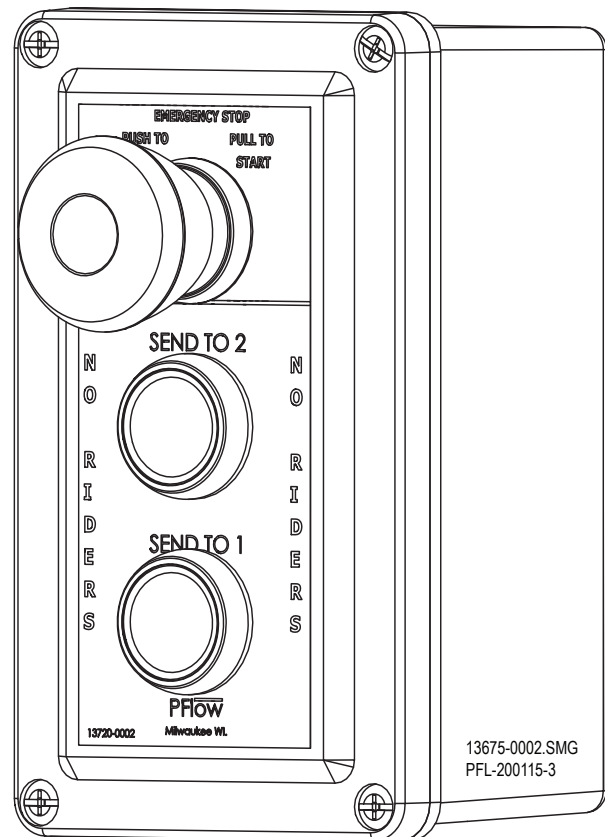

Push-Button Station Figure 9-6





Before You Begin

Read this entire manual.

This section is provided for the assistance of qualified and trained service technicians only and is not intended for use by untrained or unauthorized service personnel. This section is not a replacement for the NORD Drivesystems instructions. Additional resources and information can be found at www.nord.com under the Documentation tab.

NOTICE

A qualified person is defined as a person who, by possession of a recognized degree or certificate of professional standing, or by extensive knowledge, training, and experience, has successfully demonstrated his/her ability to solve problems relating to the subject matter and work.

Personnel to carry out work at the brake must exclusively be qualified personnel who - based upon their education, experience, instructions as well as knowledge concerning relevant standards and provisions, accident prevention, regulations and operating conditions - have been authorized by the person being responsible for safety, to carry out the activities described in these instructions and who - when doing so - are in a position to recognize possible risks early and to avoid them.

Important Safety Information



⚠ DANGER



High Voltage! Installation or maintenance work may only be performed when no power is available to the motor. Electric motors, electrical brakes, and variable frequency drives contain potentially dangerous high-voltage. Shut down the power at the circuit breaker or power switch. Employees servicing or maintaining VRCs may be exposed to death or serious personal injury if hazardous energy is not properly controlled. De-energize any circuit before work is begun. Follow your facilities procedures or OSHA lockout/tagout (LOTO) procedures anytime maintenance or service is being performed on any electrical box or component.



Burn Hazard! Surfaces of motors and gear units may become hot during operation or shortly after start-up. In some instances additional protection against accidental contact may be necessary. Use caution to avoid burns or serious injury!



Environment

Friction surfaces and the friction lining should not under any circumstances be in contact with oil or grease since small quantities reduce the braking torque considerably!

General Operating Conditions:

Operating time: 100%

Ambient temperature: Up to 40°C (104°F)

Should any of the above parameters be exceeded contact the PFlow Industries, Inc. Customer Support Department for advice.



Ambient Temperature

- The “Ambient Temperature” is intended to be an operation guideline based upon the typical properties of the lubricant. The viscosity and other properties of the lubricant change based upon load, speed, ambient conditions, and reducer operating temperatures. The user should consult with their lubrication supplier before considering changes in oil type or viscosity.
- To prevent reducer overheating, observe the maximum operating oil temperature limits:
Mineral Oil: 80-85°C (176°F – 180°F)
Synthetic Oil: 105°C (225°F)
- In the following instances, please consult PFlow Industries, Inc. Customer Support Department for specific recommendations:
 - Gear units will operate in high ambient temperature conditions exceeding 40°C (104°F).
 - Gear units will operate in cold ambient temperature conditions approaching 0°C (32°F) or lower.
 - Lower than an ISO VG100 viscosity oil is being considered for a cold-temperature service.
 - Fluid grease is required for lubricating the gear unit.



Directive and Standards

The spring-applied brake was produced in accordance with the following EC directives and standards:

- EC Directive Machinery (2006/42 EC)
- EN ISO 12100-1 and 12100-2: Safety of Machinery (Basic Concepts)
- EC Directive Electromagnetic Compatibility (2004/108 EG). Compliance with this directive has to be safeguarded with the appropriate switchgear of the user.

The spring-applied brake is not an independently operable machine but intended to be installed in other machinery. Its commissioning is prohibited until the establishment is reached that the machines comply with the provisions of the EC Directive.

Labeling

The lettering of the spring-pressure brake includes important data. This data and the contractual provisions for the brakes establish the limits of use.

Lettering on the brake housing:

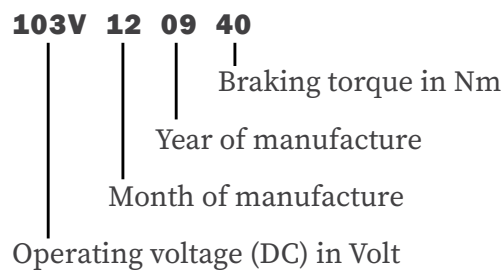

Type Code

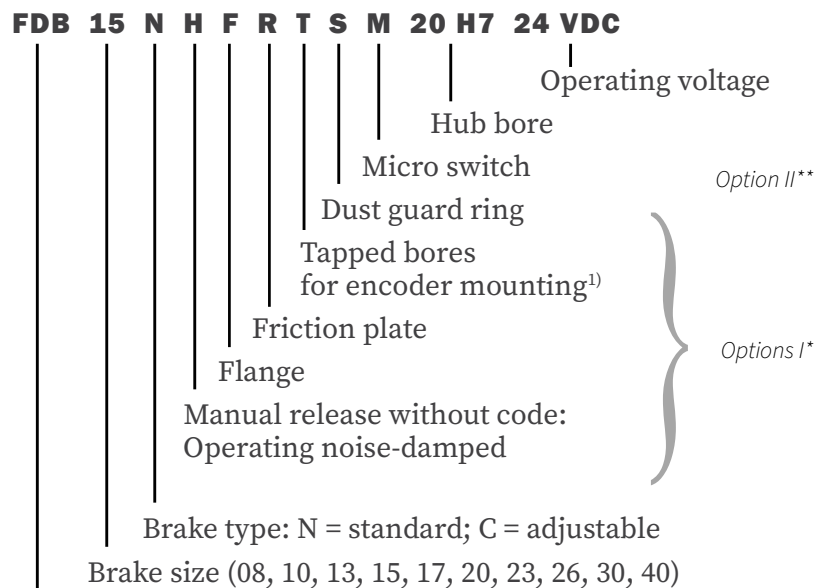

Brake designation (series)

¹⁾ only available on Design **N**

* Options I must be requested at the time of order (e.g., by using the code)

** Option II is the only option for the **FDB** series. This option, if required, must be indicated at the time of order and is not retrofittable. Instructions for the micro switch must be observed.



Reducer Nameplate

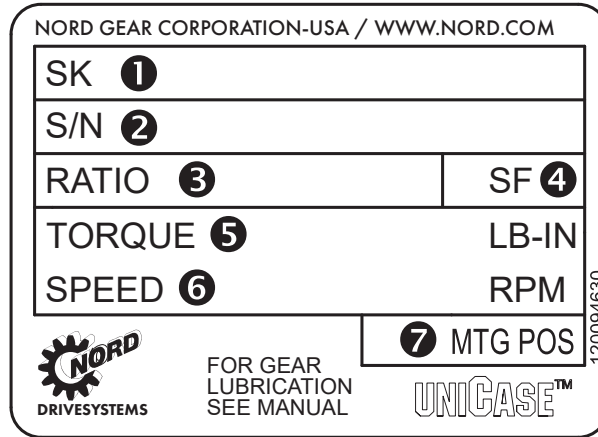

- 1** Model/Type
- 2** Serial Number
- 3** Gear Ratio
- 4** Service Factor
- 5** Torque Rating
- 6** Output Speed RPM
- 7** Mounting Position

NOTICE

Observe the data on all reducer nameplates and verify published ratings for the NORD item(s) in question. Do not operate any NORD equipment outside the published performance range. Failure to comply may result in damage to the drive unit, driven machine, or the environment.



Motor Options and Nomenclature

PFlow Industries, Inc. offers many options for its motors. The option code will be shown in the motor nomenclature.

Lettering on the motor housing:

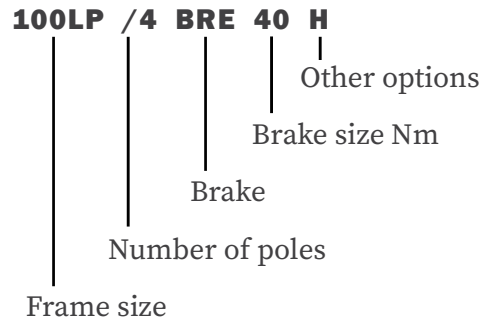

Motor Option Codes

AICM	Additional Internal Insulation Coating Applied	OL	TENV Motor – Without Fan / With Cover
BRE	With Brake	OL/H	TENV Motor - Without Fan & Cover
EAR	Single Phase, Start Cap/Run Cap	P	Premium Efficient Motors
ECR	Single Phase, Start Cap/Run Cap Increased SF	RD	Canopy Cover
EHB	Single Phase, Run Capacitor Only	RDD	Double Canopy Cover
EP	Epoxy Dipped Windings	RG	Brake – Corrosion Protected
F	Blower Cooling Fan - 3ph and 1ph	RLS	Backstop
FC	Blower Cooling Fan - 1ph	SH	Motor Space Heater
FHL	Brake – Lockable Manual Release	SR	Brake – Dust Protected
H	Energy Efficient	TF	Thermistor
HL	Brake – Manual Hand Release	TW	Thermostat
IG	Incremental Encoder	VN	10:1 Constant Torque Rated Motor
IP66	IP66 Environmental Protection	VR	5:1 Constant Torque Rated Motor
IR	Brake – Current Sensing Relay	VW	20:1 Constant Torque Rated Motor
KB	Condensation Holes - Removable Plugs	VZ-F	1000+:1 Constant Torque Rated Motor
KD	Condensation Holes - Open	WE	2nd Motor Shaft End
MIK	Brake – Microswitch	WU	High Slip Rotor
MS	Power Plug Connector	Z	High Inertia Motor Fan

Basic Brake Operation

The standard NORD motor brake is “spring-set”. When power is removed and the brake is de-energized (power-off), the brake springs exert a force against the armature plate in turn preventing the brake rotor (or brake disc) from rotating. When the brake coil is energized (power-on), a magnetic field builds and pulls the armature plate across the air gap to the brake casing, which releases the brake rotor and allows the motor shaft to rotate.

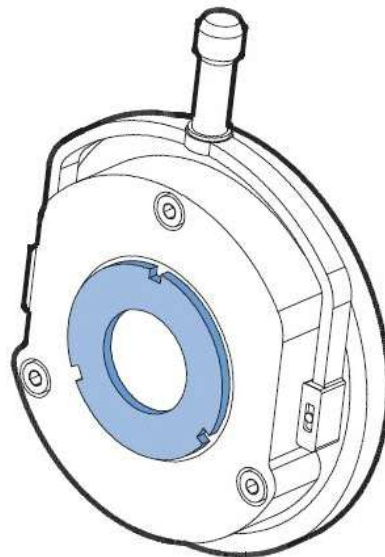
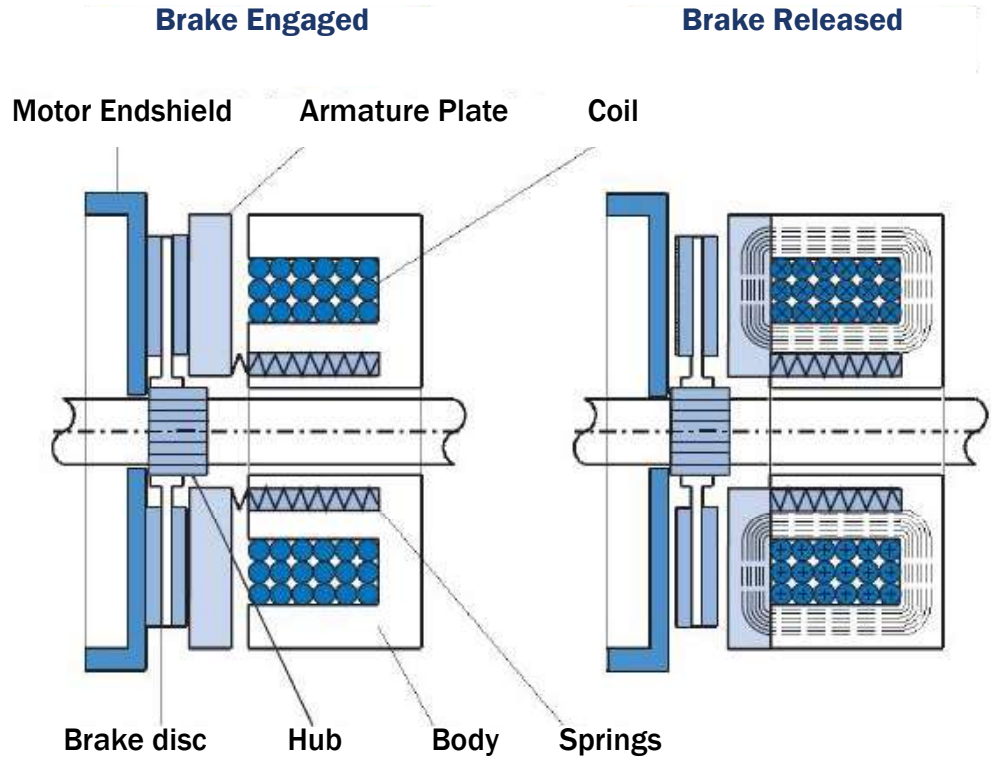

Detailed Brake Operation

The electromagnetically released spring-applied brakes of the FDB series are fail-safe brakes. The braking torque is generated by the means of spring force, and released by magnetic force.

During braking, the pressure springs (item 4) apply pressure to the armature plate (item 2) trapping the rotor (item 3.1 and 3.2) which is keyed to the machine shaft, against the counter-friction surface (flange (item 7), friction plate (item 8) or motor flange). The two friction sides of the rotor and the armature disk and/or the counter-friction surface produces the braking torque.

During release, a magnetic force is produced through applying a direct voltage to the magnet body (item 1.1 / 1.2) via the field winding. Said magnetic force draws the armature disk (item 2) to the magnet body and the brake rotor is released.

During manual release (only if brakes are designed with manual release), the armature disk is mechanically pulled against the magnet body by pulling the manual release handle (item 5, with screwed-in manual releasing lever [item 5.1]) and thus the rotor is released. This enables you to release the brake, for example, even if there is a power failure.



CAUTION

Carriage drop hazard! For safety reasons, the adjustment of the manual release must not be changed!

- 1 Magnet Body
- 2 Armature Plate
- 3 Rotor
- 4 Pressure Springs
- 5 Manual Release Handle
- 7 Flange
- 8 Friction Plate
- 10 Adjusting Ring

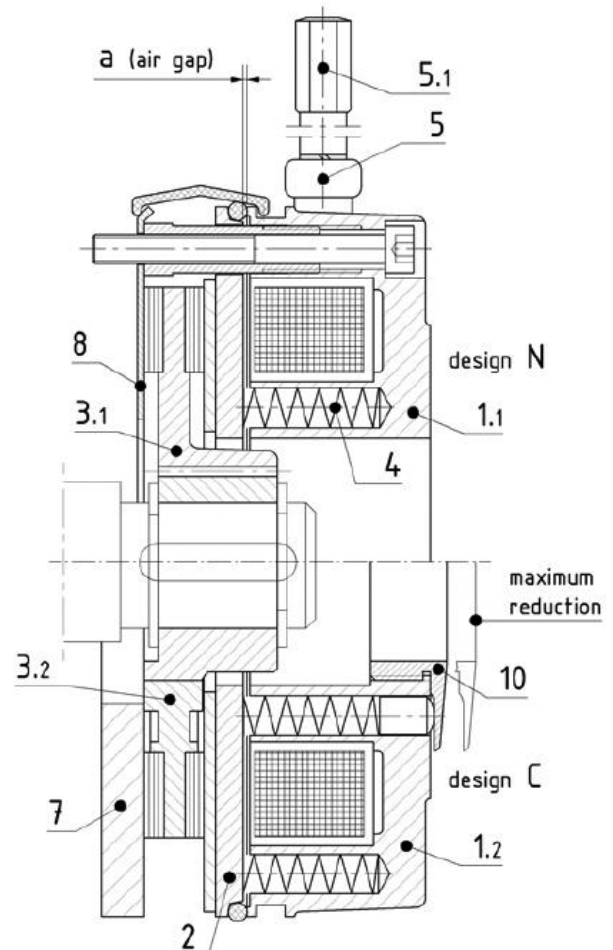

Brake Running Operation

Without any malfunctions occurring, the running operation does not require any maintenance except for verifying the size of the air gap (this increases as the lining on the rotor wears). The air gap must be verified in accordance with the following schedule unless a particular sensor for wear monitoring has been included in the brake.

Inspection intervals:

Working brake: According to service life calculation
According to specifications made by the customer

Holding brake: At least every two years
According to specifications made by the customer
Use shorter intervals in case of frequent emergency stops

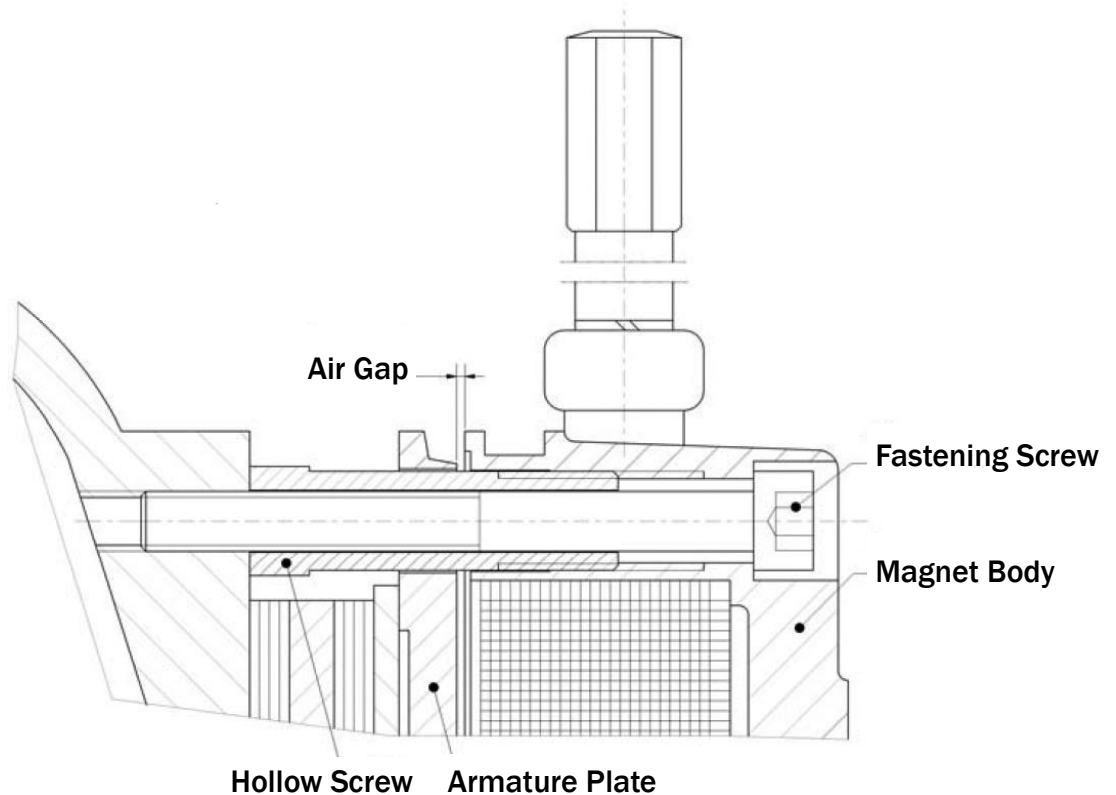



Before You Begin

Read this entire manual.

This section is provided for the assistance of qualified and trained service technicians only and is not intended for use by untrained or unauthorized service personnel. This section is not a replacement for the NORD Drivesystems instructions. Additional resources and information can be found at www.nord.com under the documentation tab.

NOTICE

A qualified person is defined as a person who, by possession of a recognized degree or certificate of professional standing, or by extensive knowledge, training, and experience, has successfully demonstrated his/her ability to solve problems relating to the subject matter and work.

Personnel to carry out work on the motor and brake must exclusively be qualified personnel who - based upon their education, experience, instructions as well as knowledge concerning relevant standards and provisions, accident prevention, regulations and operating conditions - have been authorized by the person being responsible for safety, to carry out the activities described in these instructions and who - when doing so - are in a position to recognize possible risks early and to avoid them.

Important Safety Information



DANGER



High Voltage! Installation or maintenance work may only be performed when no power is available to the motor. Electric motors, electrical brakes, and variable frequency drives contain potentially dangerous high-voltage. Shut down the power at the circuit breaker or power switch. Employees servicing or maintaining VRCs may be exposed to death or serious personal injury if hazardous energy is not properly controlled. De-energize any circuit before work is begun. Follow your facilities procedures or OSHA lockout/tagout (LOTO) procedures anytime maintenance or service is being performed on any electrical box or component.



Burn Hazard! Surfaces of motors and gear units may become hot during operation or shortly after start-up. In some instances additional protection against accidental contact may be necessary. Use caution to avoid burns or serious injury!

- Make certain the load is supported when servicing the brake. Removing power from the brake or removing the brake from the motor will release the load, which may cause severe injury or death.
- Keep clear of unsupported platforms. Stay out of the area under a raised platform. If a maintenance operation requires the carriage to remain in the raised position, physically secure the carriage at the upper level using adequately sized maintenance chains, maintenance pins, DeckLocks, or straps with shackles around the drivebase that are capable of supporting the weight of the carriage to provide additional safety.

Basic Brake Operation

The standard NORD motor brake is “spring-set”. When power is removed and the brake is de-energized (power-off), the brake springs exert a force against the armature plate in turn preventing the brake rotor (or brake disc) from rotating. When the brake coil is energized (power-on), a magnetic field builds and pulls the armature plate across the air gap to the brake casing, which releases the brake rotor and allows the motor shaft to rotate.

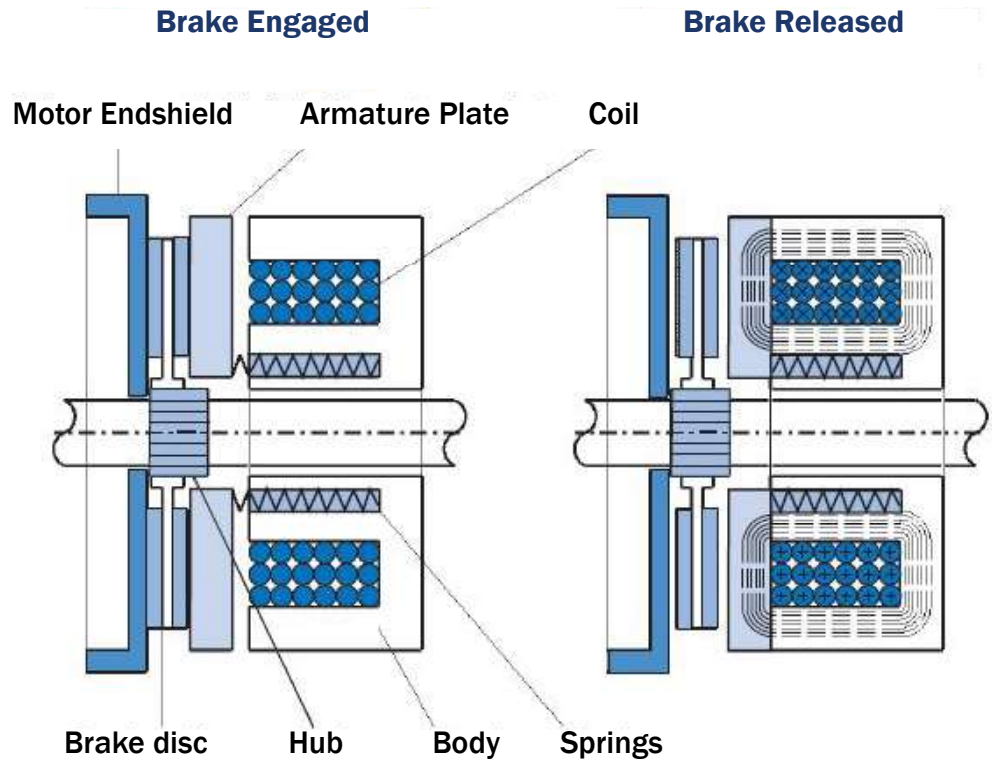

Brake Action View Figure 11-1

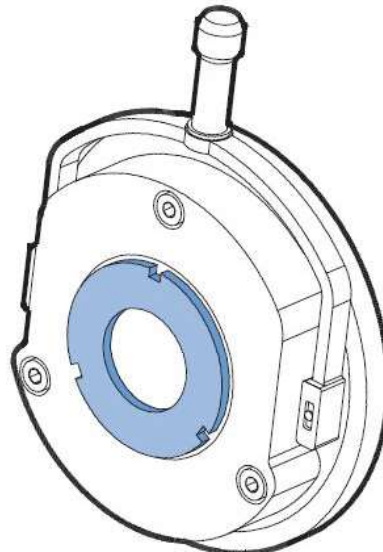

Brake Air Gap

Without any malfunctions occurring, the running operation does not require any maintenance except for verifying the size of the air gap (See Figure 11-2) (this increases as the lining on the rotor wears). As the brake rotor wears and decreases in thickness, the air gap will increase. If the air gap is too large, the brake coil may not have enough magnetic force to pull the metal armature disc across the gap and the brake will drag. The air gap must be verified in accordance with the following schedule unless a particular sensor for wear monitoring has been included in the brake.

Inspection intervals:

Working brake:
Inspect the motor after every 500 operating hours.
Use shorter intervals in case of frequent emergency stops.

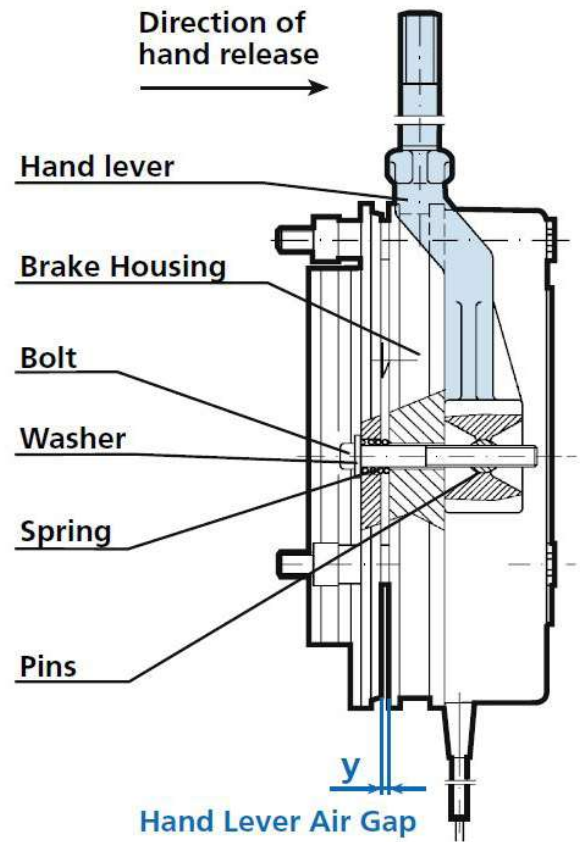

Air Gap Location Figure 11-2

Hand-Lever Air Gap Values

The air gap must be measured with a feeler gauge at **three different positions around the brake** between the metal anchor plate and the brake coil housing.

Brake Size	Dimension "y" ❶		Brake Size	Dimension "y" ❶	
	[mm]	[in]		[mm]	[in]
BRE 5	1	0.040	BRE 100	1.2	0.047
BRE 10	1	0.040	BRE 150	1.2	0.047
BRE 20	1	0.040	BRE 250	1.5	0.059
BRE 40	1	0.040	BRE 400	1.5	0.059
BRE 60	1	0.040	BRE 800	1.5	0.059
			BRE 1200	1.5	0.059

❶ Tolerance: + 0.008 in [+ 0.2 mm]

NOTICE

If the brake is ordered as a replacement part, the air gap must be set in the field. All brake air gap adjustments must be made with the brake assembled onto the motor and power off (brake engaged).

Brake Maintenance

The spring-loaded brake is virtually maintenance-free. However, when the maximum air gap is reached, an adjustment of the air gap is required for the safe operation of the brake. The functional capability and safety function of the brake will be compromised as additional wear occurs and must be replaced.

Adjust the Air Gap

1. While viewing the back of the motor (see Figure 11-3) loosen the fixing screws that attach the brake to the motor's end-shield by approximately half a turn. The brake assembly may be further loosened by turning the setting bolts or hollow screws counter-clockwise into the brake coil housing.
2. The desired nominal air-gap for each brake size is displayed in the table below. In the course of making adjustments, the air gap measurement must be verified in several places using a feeler gauge. The feeler gauge should be positioned between the armature plate and the brake coil housing as indicated in Figure 11-3.

3. **Decreasing the Air Gap** – To decrease the air gap, turn the setting bolts or hollow screws counter-clockwise while securing the fixing screws; alternatively, turn the fixing screws clockwise while securing the setting bolts or hollow-screws.
4. **Increasing the Air Gap** – To increase the air gap, turn the setting bolts or hollow screws clockwise while securing the fixing screws; alternatively, turn the fixing screws counterclockwise, while securing the setting bolts or hollow screws.
5. Re-tighten the fixing screws to the proper torque as indicated in the table.
6. Re-verify the air gap in several places and repeat the above steps as needed until the air gap spacing is uniform and consistent all around the brake.

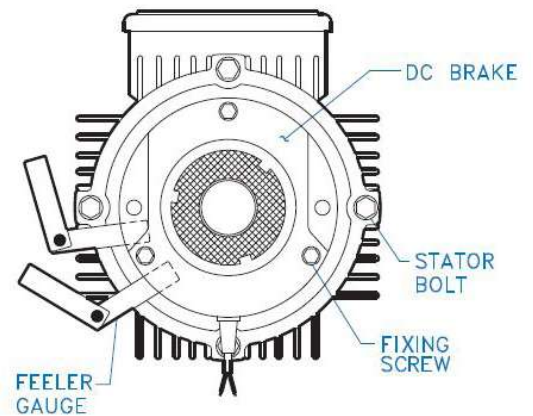

BACK OF MOTOR
(FAN SHROUD REMOVED)

Back of Motor Figure 11-3

Brake Size	Fixing Screw Tightening Torque		Nominal Air Gap Setting ①		Maximum Air Gap ②	
	[lb-ft]	[Nm]	[in]	[mm]	[in]	[mm]
BRE 5	2.2	3	0.008	0.2	0.024	0.6
BRE10	4.4	6	0.008	0.2	0.028	0.7
BRE20	7.4	10	0.012	0.3	0.031	0.8
BRE40	7.4	10	0.012	0.3	0.035	0.9
BRE60	18	25	0.012	0.3	0.039	1.0
BRE100 ③	18	25	0.016	0.4	0.043	1.1
BRE150 ③	18	25	0.016	0.4	0.043	1.1
BRE250	37	50	0.020	0.5	0.047	1.2
BRE400	37	50	0.020	0.5	0.047	1.2
BRE800	37	50	0.028	0.7	0.047	1.2
BRE1200	37	50	0.028	0.7	0.047	1.2

- ① Tolerance: + 0.004 in [+ 0.1 mm]
- ② Brake air gap must be re-adjusted before the stated value.
- ③ When using the stainless steel friction plate (RG) increase the nominal air gap to 0.2 mm (0.008 in.).

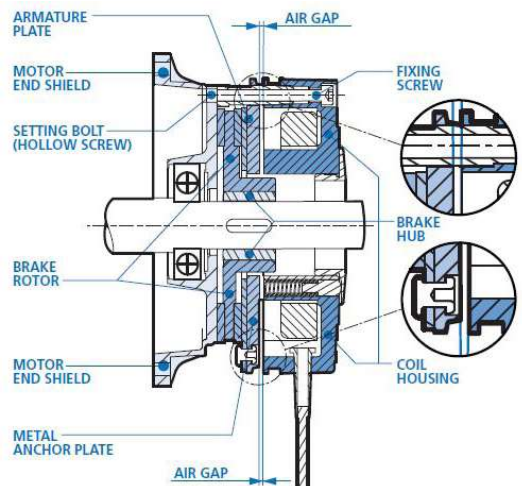

Air Gap Location Figure 11-4

NOTICE

If the brake is ordered as a replacement part, the air gap must be set in the field. All brake air gap adjustments must be made with the brake assembled onto the motor and power off (brake engaged).



**Troubleshooting
 the Brake**

The following table includes typical problems during the operation of the brake, the possible causes, and instructions on how to solve the problem.

Malfunction	Possible Cause	Solution
Brake does not release	Air gap is too large.	Inspect and adjust air gap.
	Brake is not supplied with voltage.	Verify electrical connection.
	Voltage at the coil is too low.	Verify the supply voltage of the coil.
Brake release is delayed	Air gap is too large.	Inspect and adjust air gap.
	Voltage at the coil is too low.	Verify the supply voltage of the coil.
Brake does not engage	Voltage at the coil is too high.	Verify the supply voltage of the coil.
	Hand release is adjusted incorrectly.	Adjust air gap.
	Armature plate is obstructed.	Remove the obstruction.
Brake application is delayed	Voltage at the coil is too large.	Verify the supply voltage of the coil.
	Brake is switched to AC side.	Use DC switching.



Removing the Brake



The brake can only be removed after power has been disconnected from the VRC, the brake and motor has been de-energized, and the brake is torque-free.

! DANGER



High Voltage! Employees servicing or maintaining VRCs may be exposed to death or serious personal injury if hazardous energy is not properly controlled. De-energize any circuit before work is begun. Follow your facilities procedures or OSHA lockout/tagout (LOTO) procedures anytime maintenance or service is being performed on any electrical box or component.

Disposal of the Brake and Gear Motor

Because of the different material components, the components of our spring-applied brakes and gear motors must be disposed of and recycled separately. Properly dispose of all used gear units and internal parts in accordance with all local regulations.



Components	Material
Gear wheels, shafts, rolling bearing, parallel keys, snap rings, spacers, shims, etc.	Steel
Gear housing and housing components	Cast iron or Aluminum (depending on type and size)
Worm gears	Bronze alloy
Radial seals, sealing caps, and rubber components	Elastomers with some steel
Coupling components	Plastic or Elastomer with steel
Housing gaskets and flat oil seals	Asbestos-free sealing or gasket material (various types used)
Gear Oil	Mineral, SHC-Synthetic or PG-Synthetic (can vary)



NOTICE Improper oil levels may lead to premature component wear and diminished service life. The gear reducer may not receive proper lubrication if the unit is not mounted in the position for which it is designed.

Do not weld on the gear unit or use the gear unit as an earth or ground connection for any welding procedure as this may cause permanent damage to the bearings and gears.

Unless special measures are taken, the immediate vicinity around the gear drive or motor should not be exposed to any aggressive or corrosive substances, contaminated air, ozone, gases, solvents, acids, alkalis, salts, radioactivity, etc.

The single shaft key must engage the full bore-land length at each end of the hollow shaft.

**Gearbox
Lubrication**

Proper gearbox lubrication is essential in order to reduce friction, heat, and component wear. Lubricants reduce heat and wear by inserting a protective “fluid boundary” between mating parts and preventing direct metal to metal contact. Lubricants also help prevent corrosion and oxidation, minimize foam, improve heat transfer, optimize reducer efficiency, absorb shock loads and reduce noise.

Most reducers are shipped from the factory with a pre-determined oil fill level in accordance to the specified reducer size and mounting position.

NOTE *Consult the sticker adjacent to the fill plug to determine the type of lubricant installed at the factory. Some units have special lubricants designed to operate in certain environments or intended to extend the service life or service temperature range of the lubricant. If in doubt about which lubricant is needed for a certain application, please contact the PFlow Industries, Inc. Customer Support Department.*

**Lubrication
Replacement**

If the gear unit is filled with mineral oil, the lubricant should be replaced at least after every 10,000 operating hours or after every two years. If the gear unit is filled with synthetic oil, the lubricant should be replaced at least after every 20,000 operating hours or after every four years. Often gear reducers are exposed to extreme ambient conditions, hostile environments, wet conditions, or dirty and dusty operating areas. Especially in these situations, it is important to establish a condition-based oil service interval.

**Maximum Oil
Temperature**

To prevent reducer overheating, the reducer’s maximum oil sump temperature limit must not be exceeded for prolonged periods of operation (up to 3 hours continuous operation depending upon reducer size).

Oil Type	Maximum Oil Temperature Limit
Mineral	80 °C - 85 °C (176 °F - 185 °F)
Synthetic	105 °C (225 °F)



Oil Drain and Fill-level Plugs

All reducer drain plugs are metric and utilize sealing gaskets between the head of the plug and the reducer housing. It is standard practice to provide a hex-head screw for the fill-level plug. For ease of draining the used oil from the gear reducer, use the socket head screw located at the lowest part of the gearbox.

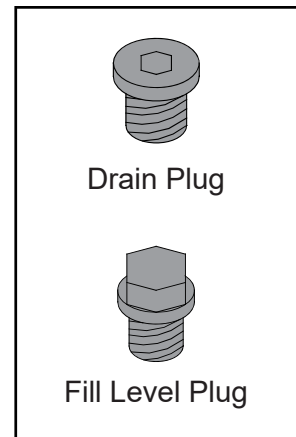

Plug Identification Figure 11-5

Oil Formulation Codes

MIN-EP	Mineral Oil with EP Additive
PAO-EP	Synthetic Polyalphaolefin Oil with EP Additive
PAO	Synthetic Polyalphaolefin Oil
PG	Synthetic Polyglycol Oil
FG	Food-Grade Oil
FG-PAO	Food-Grade, Synthetic Polyalphaolefin Oil
FG-PG	Food-Grade, Synthetic Polyglycol Oil

Oil Lubricants

Standard Oil Lubricants

ISO Viscosity	Oil Type	Ambient Temperature Range	Manufacturer Brand/Type
VG220	MIN-EP	0 to 40°C (32 to 104°)	Mobilgear 600XP220
	PAO-EP	-35 to 60°C (-31 to 140°F)	Mobil SHC Gear 220
	FG	-5 to 40°C (23 to 104°F)	Fuchs FM220

Optional Oil Lubricants

ISO Viscosity	Oil Type	Ambient Temperature Range	Manufacturer Brand/Type
VG460	PAO-EP	-35 to 80°C (-31 to 176°F)	Mobil SHC Gear 460
	FG-PAO	-35 to 80°C (-31 to 176°F)	Mobil SHC Cibus 460
VG220	FG-PAO	-35 to 60°C (-31 to 140°F)	Mobil SHC Cibus 220
VG150	PAO-EP	-35 to 25°C (-31 to 77°F)	Mobil SHC Gear 150

Ambient Temperature



- The “Ambient Temperature” is intended to be an operation guideline based upon the typical properties of all the lubricant. The viscosity and other properties of the lubricant change based upon load, speed, ambient conditions, and reducer operating temperatures. The user should consult with their lubrication supplier before considering changes in oil type or viscosity.
- To prevent reducer overheating, observe the maximum operating oil temperature limits:
Mineral Oil: 80 - 85°C (176 – 180°F)
Synthetic Oil: 105°C (225°F)
- In the following instances, please consult PFlow Industries, Inc. Customer Support Department for specific recommendations:
 - Gear units will operate in high ambient temperature conditions exceeding 40°C (104°F).
 - Gear units will operate in cold ambient temperature conditions approaching 0°C (32°F) or lower.
 - Lower than an ISO VG100 viscosity oil is being considered for a cold-temperature service.
 - Fluid grease is required for lubricating the gear unit.



Lubrication Notes

- Avoid using (EP) gear oils in worm gears that contain sulfur-phosphorous chemistries, as these additives can react adversely with bronze worm gears and accelerate wear.
- Food-grade lubricants must be in compliance with FDA 212 CFR 178.3570 and qualify as an NSF-H1 lubricant. Please consult with lubrication manufacturer for more information.
- When making a lubrication change, check with the lubrication supplier to assure compatibility and to obtain recommended cleaning or flushing procedures.
- Make sure not to mix different oils with different additive packages or different base oil formulation types. Polyglycol (PG) oils are not capable of being mixed with other oil types and should never be mixed with mineral oil or polyalphaolefin (PAO) synthetic oil.

Oil Cross-reference Chart

ISO Viscosity	Oil Type	Ambient Temperature Range	Mobil	 Shell	 Castrol	
VG220	MIN-EP	0 to 40°C (32 to 104°F)	Mobilgear 600XP220	Omala S2 G 220	Alpha SP220	Renolin EP220
	PAO-EP	-30 to 60 °C (-22 to 140 °F)	Mobil SHC Gear 220	Omala S4 GX 220	Alphasyn EP220	Gearmaster SYN220/NA
	PAO	-30 to 60°C (-22 to 140°F)	Mobil SHC630	Morlina S4 B 220	Alphasyn T220	N/A
	PG	-25 to 60°C (-13 to 140°F)	Mobil Glygoyle 220	Omala S4 WE 220	Alphasyn PG220	Renolin PG220
	FG	0 to 40°C (32 to 104°F)	Mobil DTE FM 220	N/A	N/A	Fuchs FM220
	FG-PAO	-25 to 60°C (-13 to 140°F)	Mobil SHC Cibus 220	N/A	N/A	Cassida GL220
	FG-PG	-25 to 60°C (-13 to 140°F)	Mobil Glygoyle 220	N/A	N/A	Cassida WG220



Oil Volume

Gear reducers are shipped from the factory with a pre-determined oil fill level in accordance to the specified reducer size and mounting position.

Actual oil volume can vary slightly depending upon the gear case size, mounting, and ratio. Prior to starting the reducer, check the oil-level using the reducer's oil level plug and drain or add oil as needed. The minimum acceptable oil level is 0.15" (4mm) below the oil level hole.

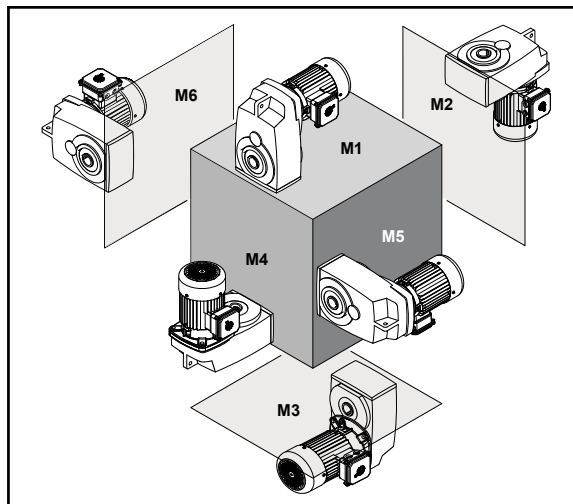

Motor and Gear Reducer Orientations Figure 11-6

Type	M1		M2		M3		M4		M5		M6	
	Quarts	Liters	Quarts	Liters	Quarts	Liters	Quarts	Liters	Quarts	Liters	Quarts	Liters
SK 0182NB	0.42	0.40	0.58	0.55	0.58	0.55	0.42	0.40	0.42	0.40	0.42	0.40
SK 0182.1	0.74	0.7	1.14	1.08	0.66	0.62	0.93	0.88	0.63	0.6	0.68	0.64
SK 0282NB	0.74	0.70	1.16	1.10	0.85	0.80	1.16	1.10	0.95	0.90	0.95	0.90
SK 0282.1	1.08	1.02	1.48	1.4	0.85	0.8	1.41	1.33	0.85	0.8	0.92	0.87
SK 1282	1.00	0.95	1.37	1.30	0.95	0.90	1.37	1.30	1.06	1.00	1.06	1.00
SK 1282.1	1.77	1.67	2.28	2.16	1.11	1.05	2.06	1.95	1.35	1.28	1.42	1.34
SK 1382NB	1.48	1.40	2.43	2.30	2.32	2.20	2.32	2.20	2.11	2.00	2.11	2.00
SK 1382	1.53	1.45	1.69	1.6	1.22	1.15	1.8	1.7	1.16	1.1	1.16	1.1
SK 1382.1	1.77	1.67	2.11	2	1.11	1.05	2.06	1.95	1.35	1.28	1.42	1.34
SK 2282	1.80	1.70	2.43	2.30	1.80	1.70	2.32	2.20	2.01	1.90	2.01	1.90
SK 2382	2.43	2.30	2.85	2.70	2.22	2.10	3.38	3.20	2.11	2.00	2.11	2.00
SK 3282	2.96	2.80	4.23	4.00	3.49	3.30	4.02	3.80	3.17	3.00	3.17	3.00
SK 3382	4.02	3.80	4.54	4.30	3.17	3.00	5.81	5.50	3.17	3.00	3.17	3.00
SK 4282	4.44	4.20	5.71	5.40	4.65	4.40	5.28	5.00	4.44	4.20	4.44	4.20
SK 4382	6.45	6.10	7.29	6.90	5.18	4.90	8.88	8.40	5.28	5.00	5.28	5.00
SK 5282	7.93	7.50	9.30	8.80	7.93	7.50	9.30	8.80	7.61	7.20	7.61	7.20
SK 5382	13.2	12.5	12.7	12.0	7.08	6.70	14.8	14.0	8.77	8.30	8.77	8.30
SK 6282	18.0	17.0	16.4	15.5	13.2	12.5	18.5	17.5	11.6	11.0	14.8	14.0
SK 6382	16.9	16.0	13.7	13.0	10.6	10.0	19.0	18.0	14.8	14.0	13.2	12.5
SK 7282	26.9	25.5	22.2	21.0	21.7	20.5	28.5	27.0	16.9	16.0	22.2	21.0
SK 7382	23.2	22.0	22.2	21.0	16.9	16.0	26.4	25.0	24.3	23.0	23.2	22.0
SK 8282	39.6	37.5	34.9	33.0	32.2	30.5	46.5	44.0	32.8	31.0	32.8	31.0
SK 8382	36.5	34.5	34.3	32.5	26.4	25.0	40.2	38.0	37.0	35.0	31.7	30.0
SK 9282	79.2	75.0	74.0	70.0	58.1	55.0	76.1 †	72.0 †	63.4	60.0	62.4	59.0
SK 9382	78.2	74.0	74.0	70.0	47.6	45.0	79.2 †	75.0 †	68.7	65.0	63.4	60.0
SK 10282	95.0	90.0	95.0	90.0	42.3	40.0	95.0 †	90.0 †	63.0	60.0	87.0	82.0
SK 10382	90.0	85.0	95.0	90.0	77.0	73.0	106 †	100 †	85	80.0	85.0	80.0
SK10382.1	80.3	76.0	84.5	80.0	75.0	71.0	98.2	93.0	76.1	72.0	70.8	67.0
SK 11282*	174	165	169	160	153	145	206 †	195 †	106	100	148	140
SK 11382*	169	160	164	155	148	140	222 †	210 †	164	155	143	135
SK11382.1*	134.2	127	140.5	133	124.7	118	205	194	131	124	118.4	112
SK 12382*	169	160	164	155	148	140	222 †	210 †	164	155	143	135

* For shipping purposes the larger gear units are supplied without oil.

† Oil quantities shown are for the gearbox only. When the OT (oil tank) option is used, the oil must be filled to the level shown on the dipstick which is located inside of the oil tank. Even when the gear unit is filled by the manufacturer, the user MUST add more oil until the oil is filled to the proper level.

Oil Plug Connections

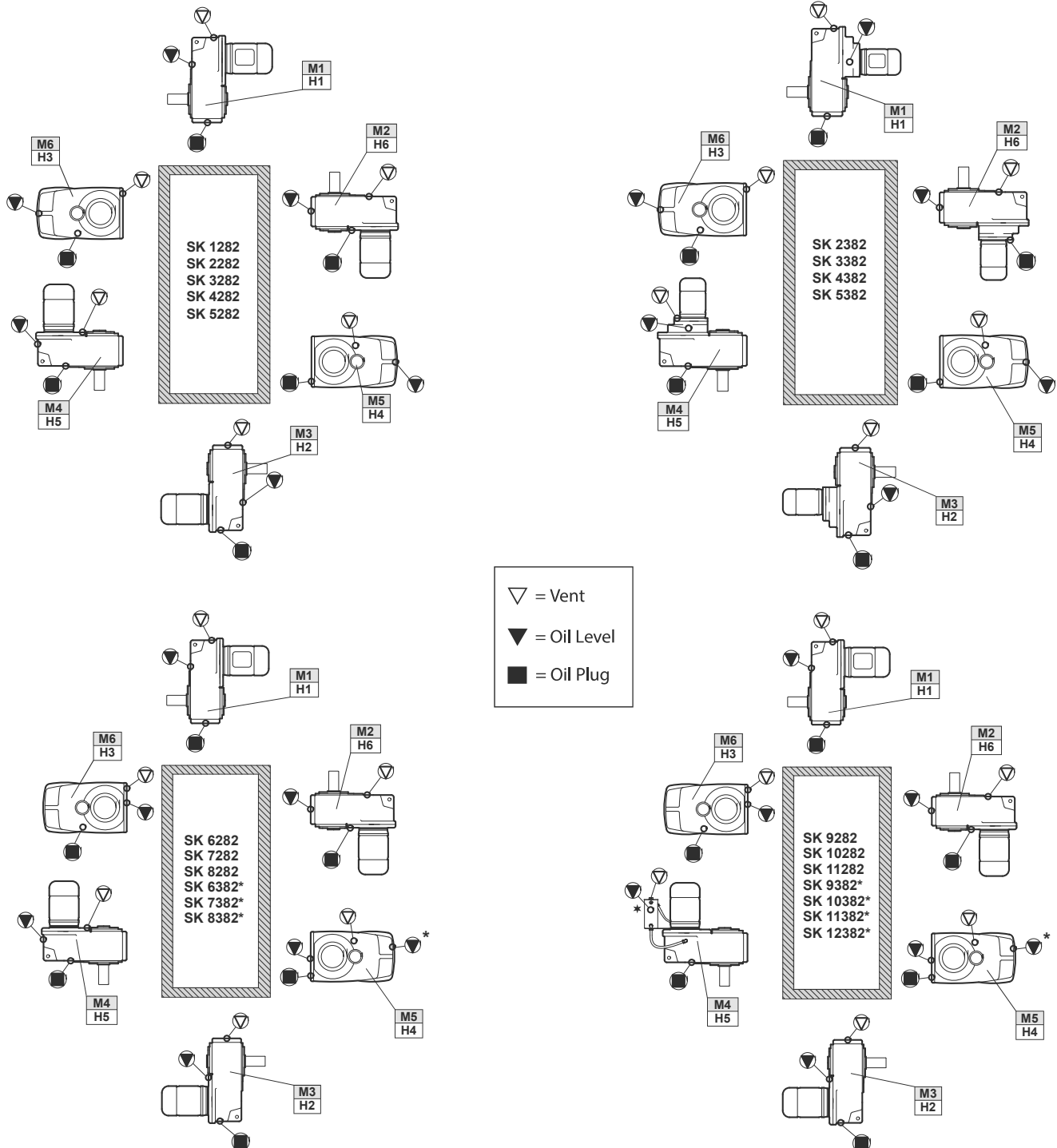

* Oil level for 3 stage gear units

* Oil level for 3 stage gear units

* Oil fill level should be verified using the dip stick located in the oil tank for the M4/H5 position.

Oil Plug Locations Figure 11-7



Troubleshooting the Reducer

The following table identifies some of the most common issues with speed reducers, the possible causes, and the suggested solution.

Malfunction	Possible Cause	Solution
Runs hot - Overloading	Load exceeds the capacity of the reducer.	Verify the rated capacity of the reducer and replace with unit with a larger capacity or reduce the load.
Runs hot - Improper lubrication	Insufficient lubrication.	Inspect lubricant level and adjust up to recommended levels.
	Excessive lubrication.	Inspect lubricant level and adjust down to recommended levels.
	Wrong lubrication.	Flush out and refill with correct lubricant as recommended.
Runs noisy - Loose foundation bolts	Weak mounting structure.	Inspect the mounting of the reducer. Tighten loose bolts and/or reinforce mounting and structure.
	Loose hold down bolts.	Tighten bolts.
Runs noisy - Failure of bearings	Lack of lubricant.	Replace the bearing. Clean and flush the reducer and fill with the recommended lubricant.
	Overload.	Verify the rated capacity of the reducer.
Runs noisy - Insufficient lubricant	Level of lubricant in reducer not properly maintained.	Verify the lubricant level and adjust to factory recommended level.
Output shaft does not turn - Internal parts are broken or missing	Overloading of reducer can cause damage.	Replace broken parts. Verify the rated capacity of the reducer.
	Key missing or sheared off on input shaft.	Replace key.
	Coupling loose or disconnected.	Properly align the reducer and coupling. Tighten the coupling.
Oil leakage - Worn seals	Caused by dirt or grit entering the seal.	Replace seals. Autovent may be clogged. Replace or clean the Autovent.
Oil leakage - Unit runs hot or leaks	Overfilled reducer.	Inspect the lubricant level and adjust to the recommended level.
	Vent clogged.	Clean or replace, making sure to prevent any dirt from falling into the reducer.
Oil leakage - Incorrect fill level	Mounting position.	Verify mounting position on the name tag and verify fill quantity on the mounting chart in manual.



WARNING

- Do not use any corrosive or flammable solvents or cleaning agents on the machine that contain TRI, PER, TETRA, or FCHC. Read the instructions on the packaging when use is made of chemical substances (cleaning agents).
- Electrical components should not make contact with water or other liquids.
- Do not clean the VRC or any of its components with compressed air or water under high pressure.
- Do not use abrasive steel pads, wire brushes, or scrapers when cleaning.
- Avoid parts made of rubber or plastic, such as cables and gaskets, from making contact with oil, solvents, or other chemicals.
- Climbing, sitting, walking, or riding on equipment while the equipment is in operation could result in death or serious injury.
- Close all gates before the carriage is moved. Never leave the VRC unattended with the gates in the open position. Never close gates when a person is on the carriage or within the fenced area.
- The most common reason for access to the area beneath the carriage is to remove debris from the pit. This is best accomplished using a long handled broom or rake to avoid entering the pit under the raised carriage deck. Only qualified person following proper lockout/tagout procedures with the carriage properly secured in a raised position are permitted to access the pit or hoistway enclosure at the bottom level. Refer to Bulletin 15709-0083 for additional information.
- Entanglement hazard! Secure long hair, wear snug-fitting clothing, and avoid wearing jewelry while using the VRC.



Cleaning

1. Remove all product from the VRC carriage.
2. Lockout the VRC in accordance with the facility Lockout/Tagout program.
3. Remove spills and dirt by hand.
4. Refer to Bulletin 15709-0083 for additional information on procedures to access the area beneath the carriage to remove debris from beneath the carriage.
5. Report any unsafe condition or damage to the personnel responsible for the VRC and make sure that any damage is remedied before restarting the VRC. Do not allow the VRC to operate when unsafe conditions arise.







The VRC requires minimal attention on a regular basis to prevent equipment failures or accelerated wear and tear. VRCs operating during multiple daily shifts need to be maintained more often. This section is provided for the assistance of qualified and trained service technicians only and is not intended for use by untrained or unauthorized service personnel. Make sure all steps are completed. A record of regular, properly conducted preventive maintenance provides a running history of any issues the VRC may have. The reports will identify trends, and helps anticipate expected wear and tear repairs. Sign and return to PFlow Industries, Inc. Customer Support Department via e-mail to csd@pflow.com

NOTICE

A qualified person is defined as a person who, by possession of a recognized degree or certificate of professional standing, or by extensive knowledge, training, and experience, has successfully demonstrated his/her ability to solve problems relating to the subject matter and work.

WARNING



- If any defects relating to operating safety and reliability are detected or if any damage occurs, the VRC must be taken out of operation immediately.
- Lockout/tagout the VRC before performing maintenance. De-energize any circuit before work is begun.
- Take appropriate measures for safely working at heights.
- Make sure that no persons or objects are within the range of any moving parts of the VRC.
- Climbing, sitting, walking, or riding on equipment while the equipment is in operation could result in death or serious injury.
- If this VRC needs to be modified in any way, contact PFlow Industries, Inc. for assistance. Do not make any unauthorized changes.
- Before the VRC is put into operation, all parts must comply with all relevant health and safety directives and regulations.
- Falling Hazard! Close all gates before the carriage is moved. Never leave the VRC unattended with the gates in the open position. Never close gates when a person is on the carriage or within the fenced area.
- Entanglement hazard! Secure long hair, wear snug-fitting clothing, and avoid wearing jewelry while using the VRC.

Section 13 | M Series Preventive Maintenance and Schedule Checklist



MATERIAL HANDLING SOLUTIONS

www.pflow.com
P 414 352 9000
F 414 352 9002
6720 N. Teutonia Ave.
Milwaukee, WI 53209

✓	Action	How Often
	Verify overall operation.	monthly
	Verify that all level stops are flush with the floor level. Adjust as necessary.	monthly
	Verify that all areas under and around the VRC are clean.	monthly
	Verify that all gates and interlocks are functioning properly.	monthly
	Verify that all electrical components are undamaged.	monthly
	Verify that all gates and enclosures are undamaged and properly installed.	monthly
	Verify that all push-button stations and Emergency Stops (e-stops) are functioning on each level.	monthly
	Identify any unsafe condition. Document and report the condition immediately to the customer and then PFlow Industries, Inc. Customer Support Department. Do not allow the VRC to operate when unsafe conditions arise.	monthly
	Verify that all nuts and bolts are tight. Adjust as necessary.	3 months
	Verify that all moving components are functioning properly.	3 months
	Inspect and lubricate all chains (e.g., lift, tensioner, gate) with non-detergent, petroleum-based SAE 30 oil. Inspect for wear, rust, bent, cracked, or binding links.	3 months
	Inspect limit switches and operation. Adjust as necessary.	3 months
	Verify that the chain sprocket is centered over the chain tube. Adjust the position if necessary. Apply Loctite® Blue #242® Threadlocker to the chain sprocket setscrew and the split collar setscrews. Tighten and torque all setscrews.	3 months
	Inspect all additional options and accessories (e.g., DeckLocks, maintenance pins) and operation. Adjust as necessary	3 months
	Visually inspect the wheelblock guide rollers for rotation interference and wear.	3 months
	Verify that all electrical connections are tight.	3 months
	Verify that all tensioners are properly adjusted. Adjust as necessary.	3 months
	Verify that the carriage is level. Adjust as necessary.	6 months
	Inspect all welding, bracing, and anchoring for structural integrity.	6 months
	Inspect all chain sprockets for wear.	6 months
	Lubricate the pillow block bearings on the drivebase with lithium axle grease. Apply Loctite® Blue #242® Threadlocker to the setscrews. Tighten and torque setscrews.	6 months
	Inspect the gear reducer oil level and replenish as necessary. The minimum acceptable oil level is 0.15" (4mm) below the oil level hole.	6 months
	Inspect the motor and brake. Measure and record the air gap on the brake.	12 months
	Inspect the wheels, roller guides, and safety cams for deterioration.	12 months
	Replace gear reducer mineral oil every 10,000 operating hours or every two years.	2 years
	Replace gear reducer synthetic oil every 20,000 operating hours or every four years.	4 years

Additional Notes or Follow-up Requirements

Customer signature:	Date work completed:
Name/Phone:	Authorized Technician(s):
Title:	Name:
E-mail:	Name:



Before You Begin

Read this entire manual before any troubleshooting and service is attempted on the Vertical Reciprocating Conveyor (VRC).

Service must be performed only by qualified and trained service technicians familiar with the safe operation of this equipment.

NOTICE

A qualified person is defined as a person who, by possession of a recognized degree or certificate of professional standing, or by extensive knowledge, training, and experience, has successfully demonstrated his/her ability to solve problems relating to the subject matter and work.

Personnel to carry out work on the VRC must exclusively be qualified personnel who - based upon their education, experience, instructions as well as knowledge concerning relevant standards and provisions, accident prevention, regulations and operating conditions - have been authorized by the person being responsible for safety, to carry out the activities described in these instructions and who - when doing so - are in a position to recognize possible risks early and to avoid them.

DANGER



- High Voltage! A licensed electrician must install all electrical connections and permanent wiring in accordance with applicable local or national electrical codes. Make sure the equipment is properly grounded in accordance with local electrical codes or, in the absence of local codes, with the current edition of the National Electrical Code NFPA No. 70.
- Keep clear of unsupported platforms. Stay out of the area under a raised platform. If a maintenance operation requires the carriage to remain in the raised position, use a means of support such as adequately sized maintenance chains, maintenance pins, DeckLocks, or straps with shackles around the drivebase that are capable of supporting the weight of the carriage. Refer to Bulletin 15709-0083 for additional information.

WARNING



- Assess the VRC and identify any potential load jams.
- Lockout/tagout equipment before performing any adjustments or maintenance. If the equipment is not locked out, it could start unexpectedly and cause injury or damage. **Make sure all personnel are aware of the potential for stored energy to be present even after the power has been locked out.** Refer to ANSI Z244.1 and OSHA 29 CFR 1910.147 for minimum requirements for a lockout/tagout system. There may be additional state or local requirements.
- Toppling Hazard! Secure all VRC components (e.g., lift chain, gate panels, enclosure panels) that may fall during the troubleshooting process.
- Falling Hazard! Secure all VRC access areas (e.g., gates, push-button stations) before any troubleshooting or service is begun. Never leave the VRC unattended with the gates in the open position. Never close gates when a person is on the carriage or within the fenced area.





The following table identifies some of the most common issues with the VRC, the possible causes, and the suggested solution.

Malfunction	Possible Cause	Solution
Push-button controls do not start the motor.	The emergency stop is pushed in.	Pull the emergency stop out.
	Gates or doors are open or ajar.	Verify that all gates and doors are closed.
	Proofed diagonal drop bar on the carriage is up.	Lower the drop bar into position.
	Main power disconnect is off.	Verify that there is a reason the power is off before turning the power on.
	Thermal overload has tripped.	Press the reset button. If it trips again, determine the cause. The motor is overheating.
	Control fuse is blown.	Investigate if the problem is related to the main power fuses or the control fuses. Correct the problem and replace the fuse.
	Power circuit between the disconnect and starter is dead.	Using a voltmeter, measure the voltage. Repair as needed.
	Loose lift chain or tensioner chain.	Tighten the chain or adjust the chain tensioner or chain sensor.
	Broken tensioner chain.	Repair or replace as needed.
Motor starts and carriage raises, but motor stops before the second level.	Gates or doors are open or ajar.	Close the gate or door. Inspect the door magnets and interlock. Adjust as needed.
	Object encountered.	Identify the problem. Remove or repair as needed.
	Drive component interference.	Remove object. Repair if needed.
	OCS relay has tripped.	Lower and remove excessive weight. Inspect brake for possible malfunction, excessive ambient temperature, or mechanical binding.
	Loose lift chain or tensioner chain.	Tighten the chain or adjust the chain tensioner or chain sensor.
	Broken tensioner chain.	Repair or replace chain as needed.



Malfunction	Possible Cause	Solution
Lift motor starts for two seconds and stops.	Overcurrent sensor or motor overload trips.	Lighten the lifted load.
Carriage fails to stop at floor level.	Floor level limit switch is inoperable.	Adjust, repair, or replace the floor level limit switch.
	Brake inoperable.	Determine cause and effect. Repair if needed.
Carriage raises but will not lower.	Safety cam has set.	Identify the problem and repair as needed.
Carriage lowers but stops early.	Debris in the pit.	Remove debris from pit and clean the area.
Rough or noisy operation.	Interference between the chain and chain guards or chain guides.	Determine the cause and correct.
	Shaft pillow block bearings are worn or dry.	Inspect, lubricate, and replace as needed.
	Motor / reducer.	Determine the cause and correct.
	Travel interference.	Identify the problem, remove, and repair as needed.
	Drive component interference.	Identify the problem, remove, and repair as needed.
	Wheel guide rollers are worn.	Inspect and replace as needed. Determine the cause and correct.
	Wheelblock guide shoe is rubbing on main beams.	Determine the cause and correct.
	Chain tensioner sprocket bushing is worn or corroded.	Inspect and replace as needed.
Motor hums but shaft does not rotate, then thermal overload trips.	Single phasing.	Use a voltmeter to ensure the incoming main leads are wired properly. Repair as needed.





Before You Begin

Read this entire manual.

Overcurrent Sensor (OCS) Purpose

The PFlow Industries, Inc. Vertical Reciprocating Conveyor (VRC) is equipped with an Overcurrent Sensor (OCS). The OCS is pre wired and located inside the electrical control panel. See Figure 15-1.

The OCS monitors the motor amp draw and provides enhanced over current protection of the lift motor. The OCS must be adjusted to the maximum “expected” current draw. If the motor current rises above the OCS set point, the OCS will trip. Tripping can be caused by a circuit malfunction, overloading the capacity of the lift, or an overhanging load trapped between floors.



Overcurrent Sensor Figure 15-1

Test and Calibrate the OCS

1. Turn the trip point dial to its lowest position.
2. Place the maximum product weight on the carriage.

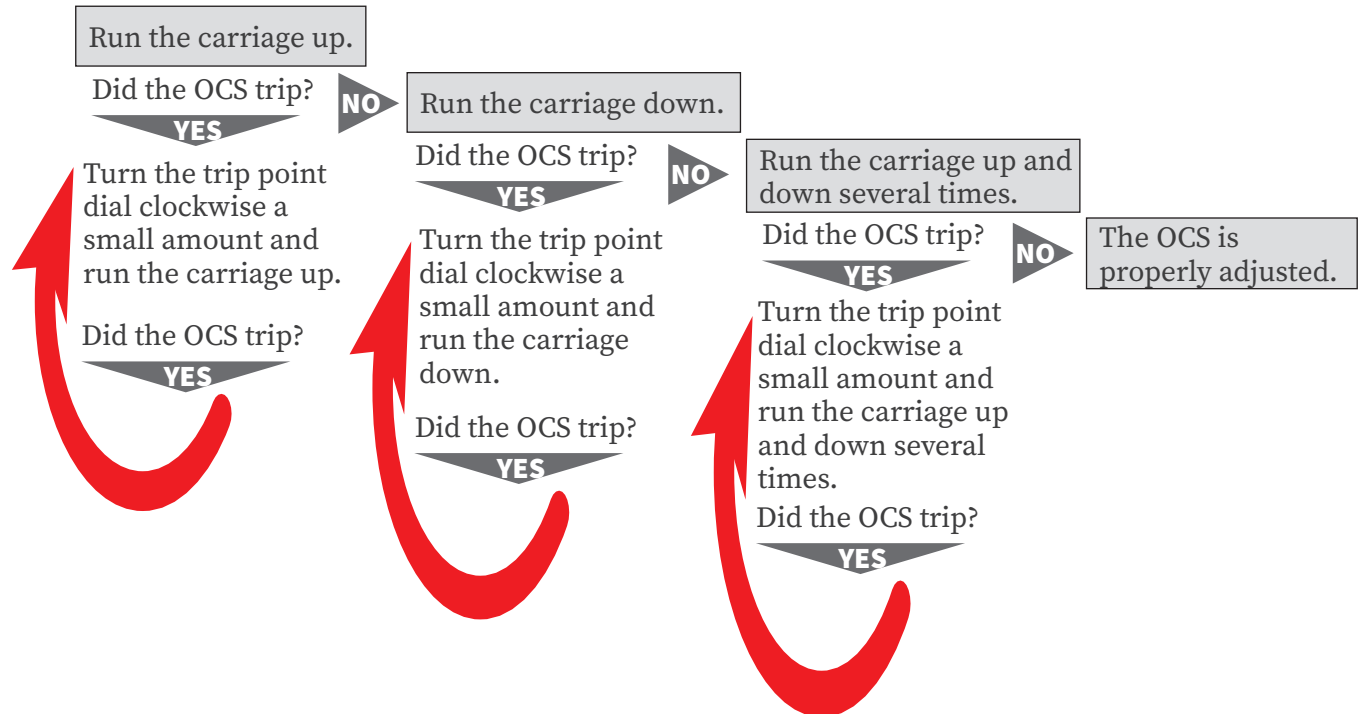

Section 15 | Adjust Overcurrent Sensor



MATERIAL HANDLING SOLUTIONS

www.pflow.com
P 414 352 9000
F 414 352 9002
6720 N. Teutonia Ave.
Milwaukee, WI 53209





This recommended spare parts list is generic (not specific to your unit). Part numbers are subject to variables specific to each application. This list is a guide to assist the customer in establishing an emergency inventory for your PFlow Industries, Inc. VRC. Convenience and minimal down time are two good reasons to maintain an inventory of spare parts. This list does not imply that any part is subject to failure. However, should any of these parts fail, the VRC could be out of service.

Description	Quantity	Part Number
Twin Roller Guide Wheelblocks		
(choose one material type - refer to Bill of Materials in Owner's Manual)		
Wheel, Nyloil (green), 3 1/2	2	
Wheel, Polyurethane (red), 3 1/2	2	
Wheel, Steel, 3 1/2	2	
Pin, 30mm	2	
Plate, Retainer	2	
Roller, Guide, 1.25 OD	4	
Bolt, Shoulder, 1/2 x 1 3/4	4	
Push-Button Stations		
PB Station	1	
Emergency Stop (E-Stop)	1	
Operator Push-button Black Flush	1	
General		
Paint 13 oz. PFlow Blue Aerosol Spray	1	
Electrical Components		
Fuse, 0.8A, 600V, Class CC, Time Delay	5	
Fuse, 1A, 250V, Time Delay	5	
Fuse, 2A, 250V, Non-Time Delay	5	
Chains and Chain Tensioners		
S Hook	2	
Swivel Round Eye Double	2	
Link, Master, #35, SBR	2	

Part numbers in this manual are subject to change or correction without notice. Minimum order charge is \$50, FOB Milwaukee, Wisconsin. Components replaced under warranty will be charged for in accordance with our RMA procedures. PFlow Industries, Inc. Customer Support Department must issue an authorization in advance of any claim for warranty and/or warranty labor. This list is based on the job as manufactured and shipped new from PFlow Industries, Inc. Any changes, updates, parts by others, or modifications after shipment are unknown to PFlow Industries, Inc.

Section 16 | Recommended Spare Parts M Series



MATERIAL HANDLING SOLUTIONS

www.pflow.com
P 414 352 9000
F 414 352 9002
6720 N. Teutonia Ave.
Milwaukee, WI 53209



Before You Begin

Part numbers in this manual are subject to change without notice. Components replaced under warranty will be charged for in accordance with our RMA procedures. Minimum order charge is \$35, FOB Milwaukee, Wisconsin.

Drivebase Assembly

These are custom-designed components and vary by job. To ensure correct replacement components are used, consult the PFlow Industries, Inc. Customer Support Department for proper part numbers. Please send a photo of the SO number from the reducer assembly and have the PFlow serial number available when requesting this information.

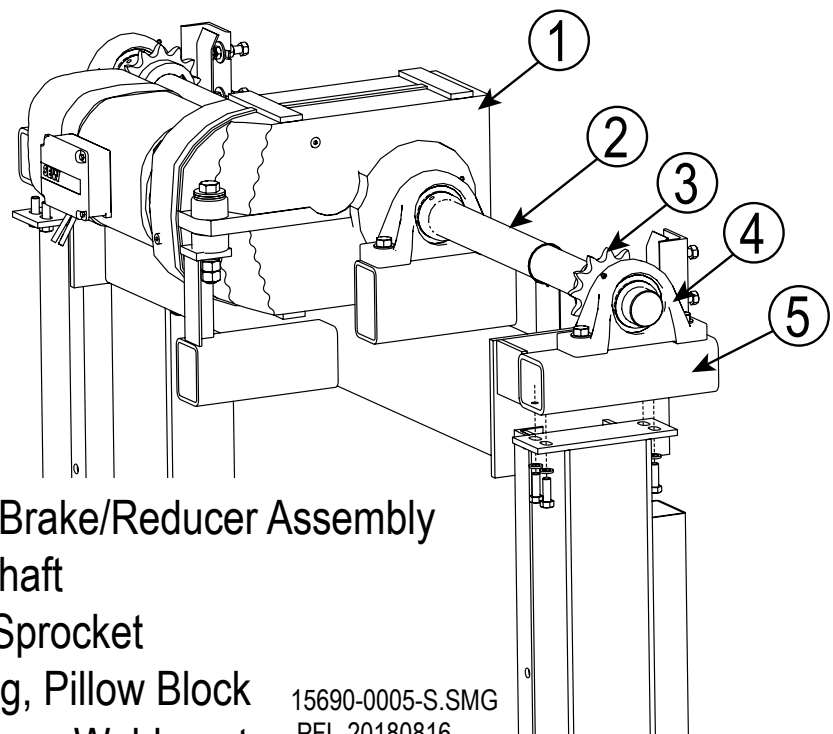

1. Motor/Brake/Reducer Assembly
2. Driveshaft
3. Drive Sprocket
4. Bearing, Pillow Block
5. Drivebase Weldment

15690-0005-S.SMG
PFL-20180816

Chain Loop Arrangement

The following drawings illustrate the path of the lift chain and tensioner chain. The size of the drive and the chains vary by application. Consult PFlow Industries, Inc. Customer Support Department before ordering.

Item	Qty	Part No.	Description
1	1	5667-0000	Chain, #60
	1	2692-0000	Chain, #80
	1	2693-0000	Chain, #100
	1	4102-0000	Chain, #120
2	2	5667-1001	Master Link, #60 Chain
	2	2692-1001	Master Link, #80 Chain
	2	2693-1001	Master Link, #100 Chain
	2	4102-1001	Master Link, #120 Chain
3	2	7651-0000	Swivel, Round Eye Double
4	2	7938-1001	Master Link, #35 Chain
5	1	7938-0000	Chain, #35 x Length
6	2	3715-0000	"S" Hook
7	1	6191-0000	Toggle, #60 Chain
	1	6190-0000	Toggle, #80 Chain
	1	6189-0000	Toggle, #100 Chain
	1	6188-0000	Toggle, #120 Chain
8	2	6187-0001	Safety Cam Link, Treated

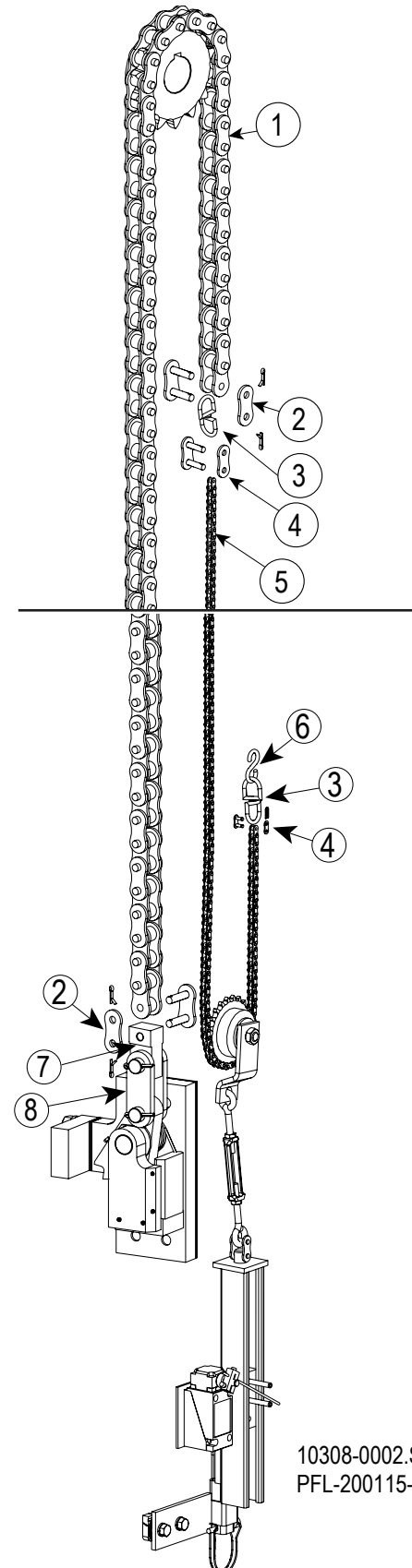

10308-0002.SMG
 PFL-200115-3



Chain Tensioner Assembly

Item	Qty	Part No.	Description
	1	10101-0000	Chain Tensioner Assembly with Right-hand Bracket, Single Pole Limit Switch, and Limit Switch Arm
	1	10101-0001	Chain Tensioner Assembly with Left-hand Bracket, Single Pole Limit Switch, and Limit Switch Arm
	1	10107-0035	Chain Tensioner Assembly without Limit Switch
1	1	10244-0035	Sprocket and Bracket Assembly
	1	10244-1000	Sprocket and Bracket Assembly, S/S
2	1	8326-0010	Nut, 5/16-18, RH Thread
3	1	2520-0000	Turnbuckle, Tensioner
4	1	3732-0010	Nut, 5/16-18, LH Thread
5	1	5667-1001	Link, Tensioner
6	1	5959-0000	Arm, Limit Switch, 5" (127mm) Long
7	1	2893-0000	Limit Switch
		2893-0005	Limit Switch, Single Pole
		6269-0000	Limit Switch, Double Pole
		2889-0006	Limit Switch, XPF 4/7
*	1	**	Bolt, Limit Switch Mounting
*	1	**	Lock Washer, Limit Switch Mounting
*	1	**	Washer, Limit Switch Mounting
*	5"	4211-0000	Channel, Unistrut, P3300, 13/16
Unistrut Mounting Hardware:			
*	2	5927-0020	Screw, HHC, 3/8-16x1.25, GR2
*	2	5858-0011	Lock Washer, Std, 3/8
*	2	6296-0011	Washer, Flat, Std, 3/8
*	2	7879-0000	Nut, Twirl, 3/8-16

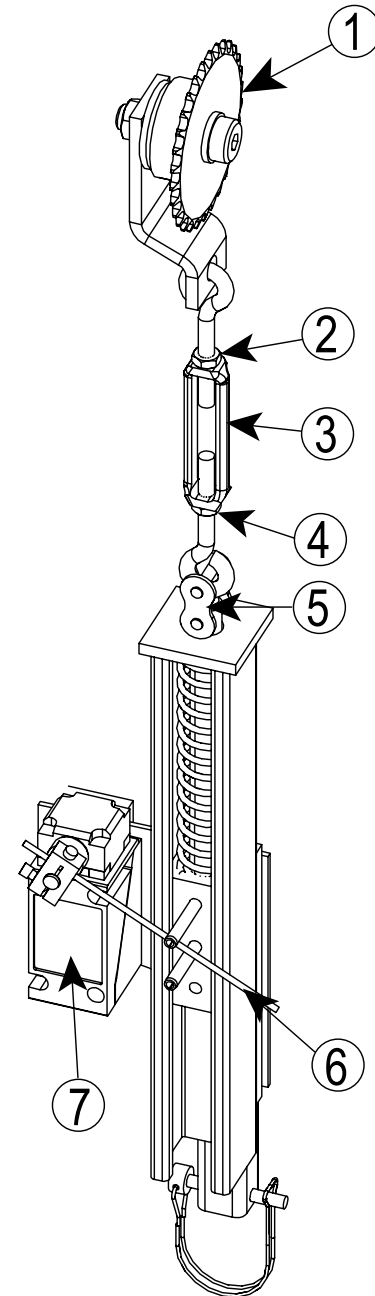

* Not Shown on Illustration

** Contact PFlow Industries, Inc. Customer Support Department for part number. VRC serial number required.

Anderson Interlock

The interlock is a device used to mechanically prevent the gate from opening. Below is the Anderson interlocks supplied. As a safety device, replacement components are only available as shown below. Some configurations may vary by application.

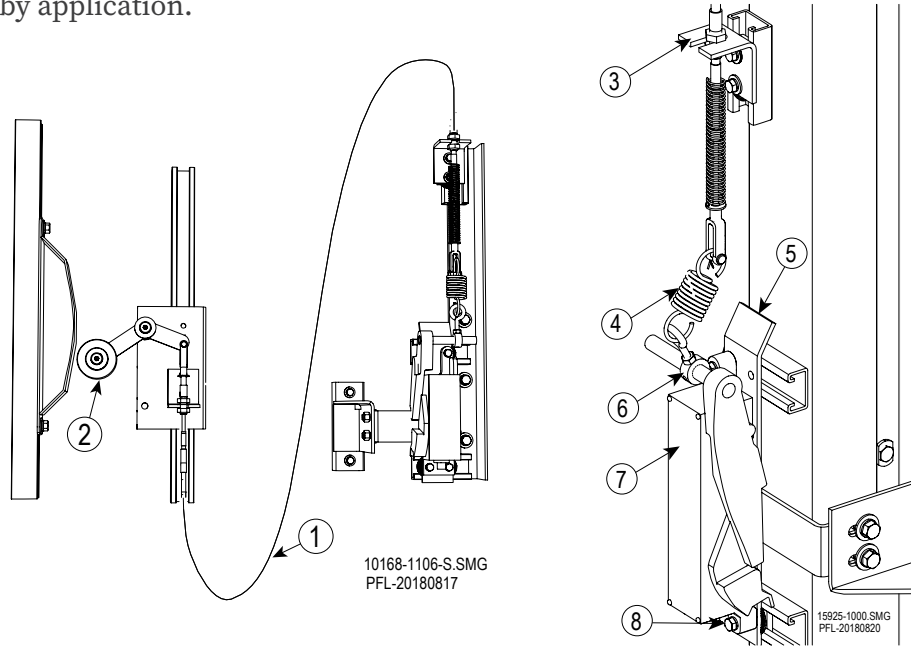

Item	Qty	Part No.	Description
1	1	9292-0120	10' Control Cable Assembly
	1	9292-0180	15' Control Cable Assembly
	1	9292-0300	25' Control Cable Assembly
	1	9292-0360	30' Control Cable Assembly
2	1	9280-0000	Roller Arm Assembly
	1	9284-0040	Wheel, Polyolefin, 2-1/2
3	1	10170-0000	Bracket, Mtg, Control Cable
4	1	**	Extension Spring
5	1	10167-0000	Plate, Interlock, Gate V.A.
6	1	9332-0009	Set Collar, Cable Interlock
	1	3694-0000	Eye Bolt, 1/4-20, 1" Long
	1	6358-0009	Hex Nut, 1/4-20, Plated
7	1	2678-0000	Interlock, Anderson, LH
	1	2678-0001	Interlock, Anderson, RH
	1	2678-4000	Interlock, Anderson, LH, Water Resistant
	1	2678-4001	Interlock, Anderson, RH, Water Resistant
	1	2678-0000-QD	Interlock, Anderson, LH, with Quick Disconnect
	1	2678-0001-QD	Interlock, Anderson, RH, with Quick Disconnect
	1	2678-4000-QD	Interlock, Anderson, LH, Water Resistant, with QD
	1	2678-4001-QD	Interlock, Anderson, RH, Water Resistant, with QD
8	1	6029-0020	Screw, HHC, 1/4-20, 1-1/4"
	1	5858-0009	Lock Washer, Std, 1/4
	1	5834-0001	Nut, 1/4-20, with Spring

** Contact PFlow Industries, Inc. Customer Support Department for part number. VRC serial number required.

PFlintlock Interlock

Item	Qty	Part No.	Description
1	1	9292-0120	10' Control Cable Assembly
	1	9292-0180	15' Control Cable Assembly
	1	9292-0300	25' Control Cable Assembly
	1	9292-0360	30' Control Cable Assembly
2	1	9280-0000	Roller Arm Assembly
	1	9284-0040	Wheel, Polyolefin, 2-1/2
3	1	10170-0000	Bracket, Mtg, Control Cable
4	1	**	Extension Spring
5	1	9332-0009	Set Collar, Cable Interlock
	1	3694-0000	Eye Bolt, 1/4-20, 1" Long
	1	6358-0009	Hex Nut, 1/4-20, Plated
6	1	11947-0001	Plate, Interlock, PFlintlock
7	1	19080-0000	Interlock, PFlintlock, 2 Contact, LH, ETL
	1	19080-0001	Interlock, PFlintlock, 2 Contact, RH, ETL
	1	19080-0002	Interlock, PFlintlock, 1 Contact, LH, ETL
	1	19080-0003	Interlock, PFlintlock, 1 Contact, RH, ETL
8	3	6029-0016	Screw, HHC, 1/4-20, 1.0, GR5
	3	5858-0009	Lock Washer, Std, 1/4
	3	7768-0009	Washer, Flat, 1/4, SAE
	3	5834-0000	Nut, Twirl, 1/4-20

** Contact PFlow Industries, Inc. Customer Support Department for part number. VRC serial number required.

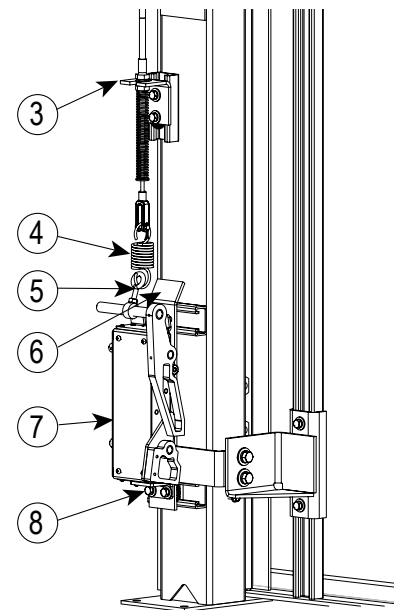
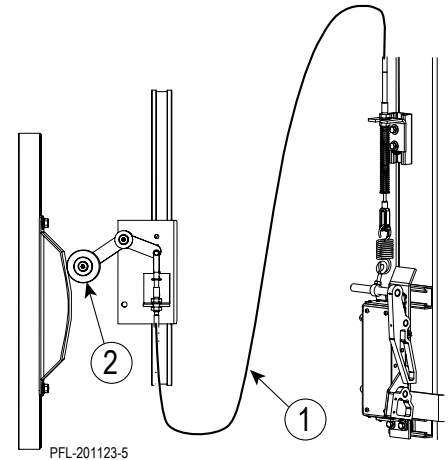

GAL Interlock

Item	Qty	Part No.	Description
1	1	13660-0000	Interlock, GAL, RH
	1	13661-0000	Interlock, GAL, LH
2	1	8078-0013	Keeper

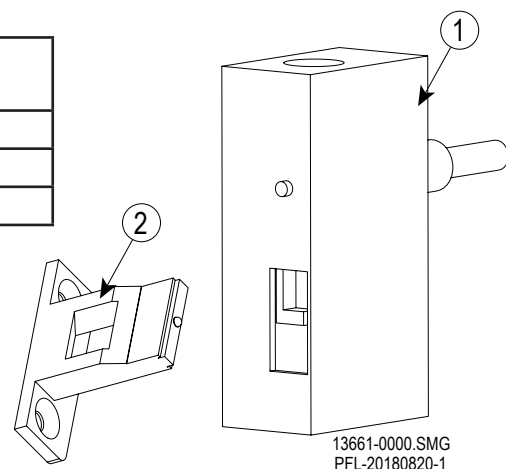



Gate Status Switches

A gate status switch is supplied when the contact are not being used. If required, it will be mounted to the gate post or header. Normally the GAL and Anderson interlocks do not use this switch. Specific order requirements may differ.

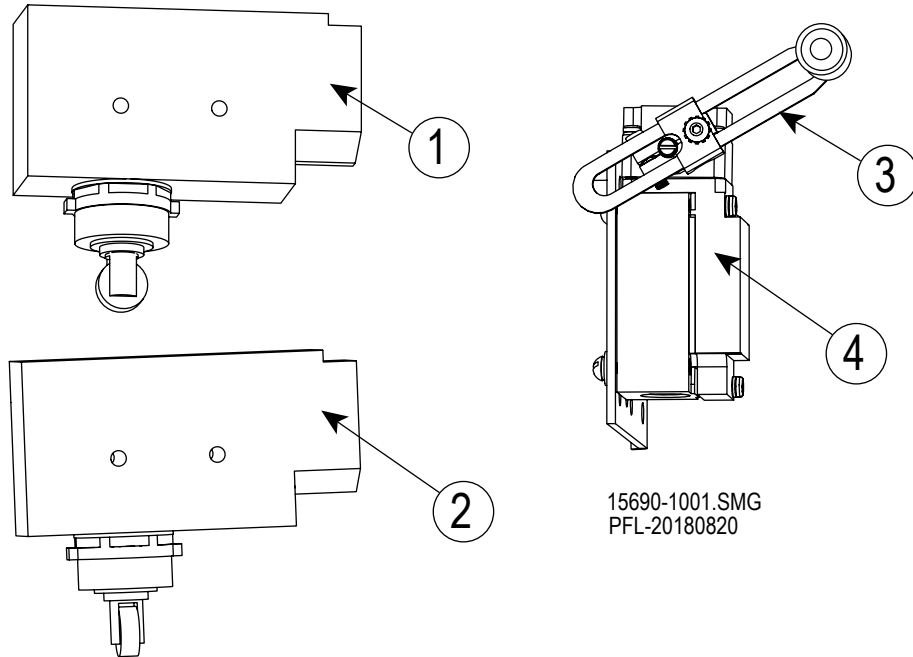

Item	Qty	Part No.	Description
1	1	6220-0000	Roller Plunger, Parallel
2	1	6216-0000	Roller Plunger, Perpendicular
3	1	2893-0000	Adjustable Roller Arm
4	1	2891-0000	Switch



Safety Cam Assembly

Columns are produced with three (3) different web flange thicknesses. Be aware that epoxy paint and galvanized coatings add to that thickness:

- 15# = .260" (+.005" coating)
- 20# = .360" (+.005" coating)
- 25# = .460" (+.005" coating)

15# Columns	Right-hand	17550-0000
15# Columns	Left-hand	17550-1000
20# Columns	Right-hand	17550-0001
20# Columns	Left-hand	17550-1001
25# Columns	Right-hand	17550-0002
25# Columns	Left-hand	17550-1002
25# Columns - HT	Right-hand	17550-0012
25# Columns - HT	Left-hand	17550-1012

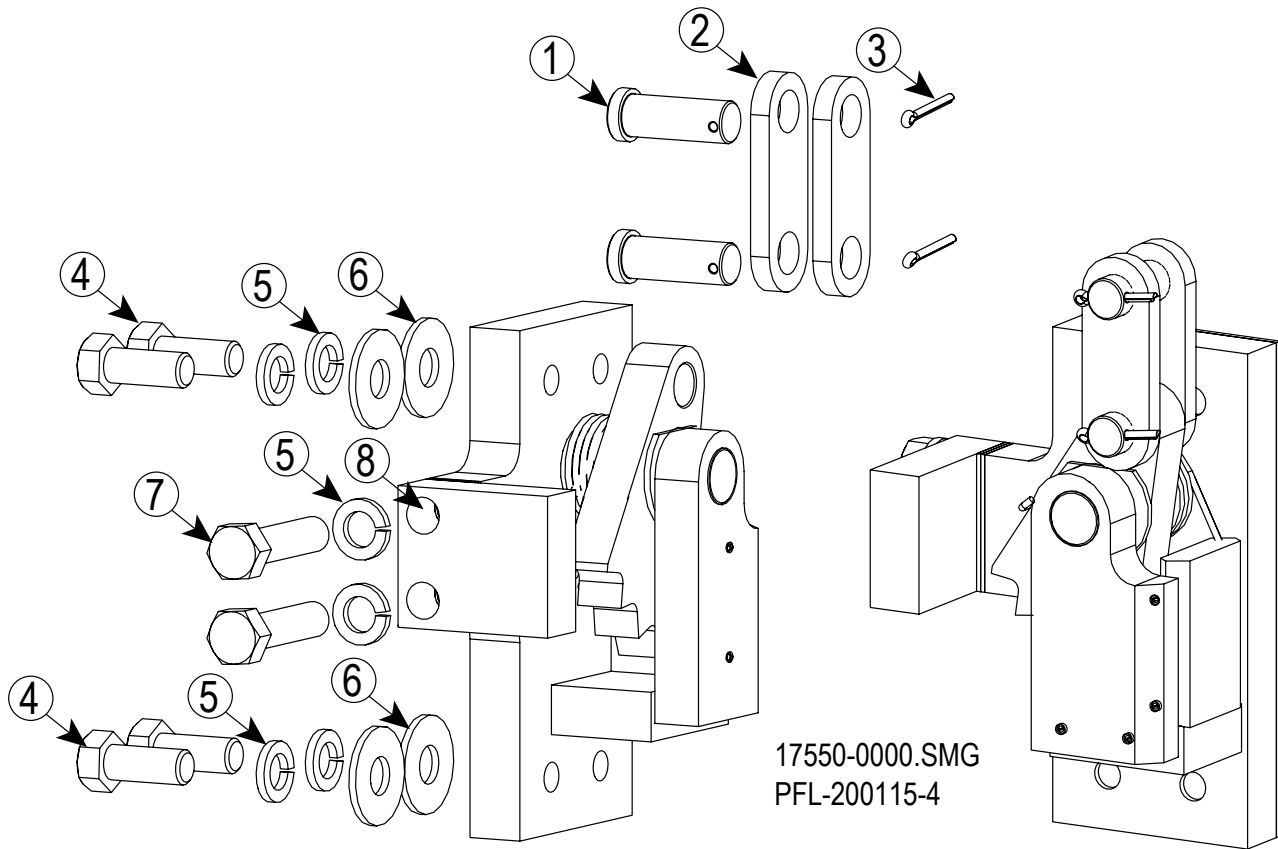

Item	Qty	Part No.	Description
1	2	8742-0032	Pin, Clevis, 15# Column
	2	2521-0000	Pin, Clevis, 20# & 25# Column
2	2	6187-0001	Link, Safety Cam, Treated
3	2	2522-0000	Pin, Cotter, 5/32 X 1 1/4
4	4	7278-0024	Screw, HHC, 5/8-11 X 1.5, Gr5

Item	Qty	Part No.	Description
5	6	5858-0015	Lock Washer, Std, 5/8
6	4	6296-0015	Washer, Std, Flat, 5/8
7	2	2198-0040	Screw, HHC, 5/8-11 X 2.25, Gr8
8	1	2754-0000	Shoe, Safety Cam
*	1	2767-0000	Spacer, Safety Cam Shoe, .08 (20# Columns)
	2	2767-0000	Spacer, Safety Cam Shoe, .08 (25# Columns)

* Not shown on illustration



Guide Roller Block Assembly - 17840-0000

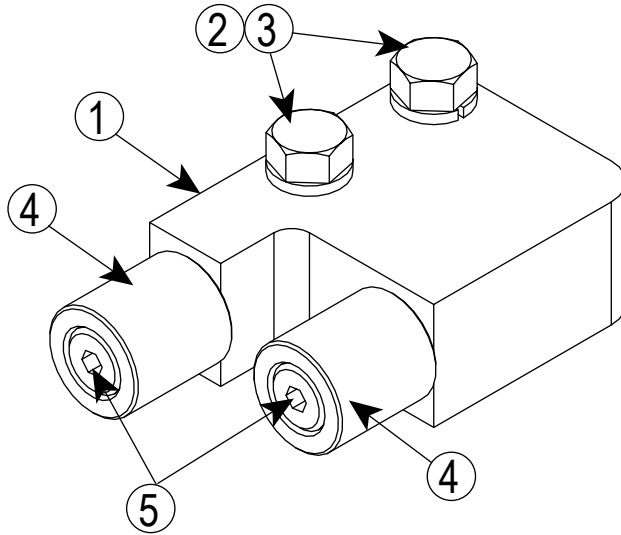

Item	Qty	Part No.	Description
1	1	17838-0000	Block, Guide Roller
2	2	9237-0040	Bolt, HHC, 1/2-13 x 2.5, GR5
3	2	5858-0013	Lock Washer, STD, 1/2
4	2	17539-0000	Roller, Guide, 1.25 OD
5	2	2503-0028	Bolt, Shoulder, 1/2 x 1 3/4

Twin Roller Guide Wheelblock Assembly

RH - 17544-0000

Nyloil Wheels (green)

LH - 17544-1000

Note: Apply moly coat grease to inside diameter of wheel prior to inserting pin.

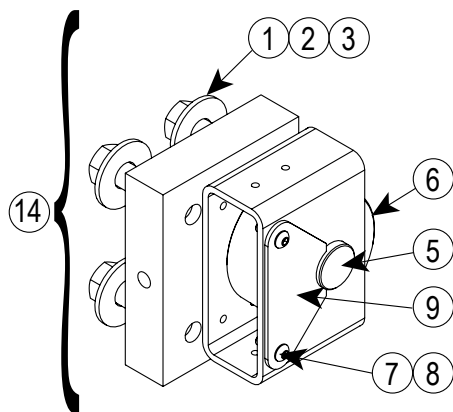
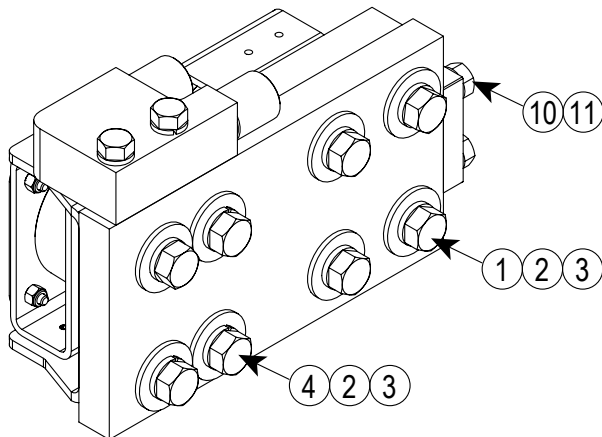
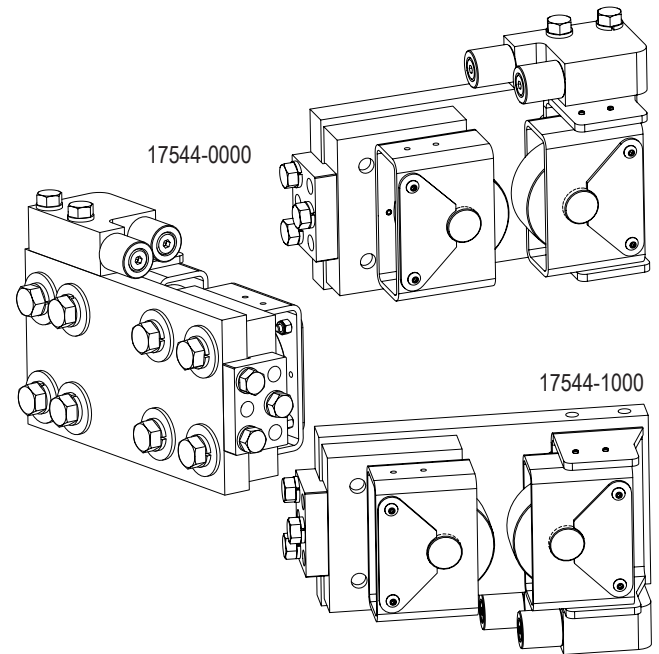
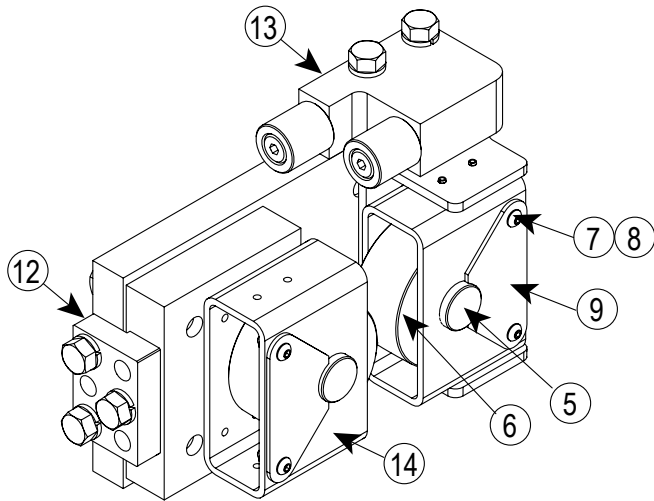

Item	Qty	Part No.	Description
1	4	6758-0036	Screw, HHC, 5/8-11 x 2.25, GR5
2	8	5858-0015	Lock Washer, Std, 5/8
3	8	6296-0015	Washer, Std, Flat, 5/8
4	4	7278-0024	Screw, HHC, 5/8-11 X 1.5, GR5
5	2	17546-0000	Pin, 30mm
6	2	17548-0000	Wheel, Nyloil, 3.5 x 1.5
7	4	2888-0012	Screw, BHSC, 1/4-20 x 3/4
8	4	6708-0009	Nut, Lock, Nylon, 1/4-20
9	2	17545-0000	Plate, Retainer
10	3	9237-0024	Screw, HHC, 1/2-13 x 1.5, GR5
11	3	5858-0013	Lock Washer, Std, 1/2
12	1	17561-0000	Bar Clamp
13	1	17840-0000	Guide Roller Block Assembly
14	1	17543-0000	Nyloil Wheel Assembly

Twin Roller Guide Wheelblock Assembly **RH - 17544-0010** **Polyurethane Wheels (red)**
LH - 17544-1010

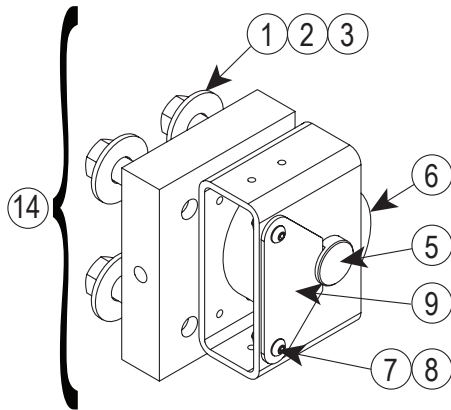
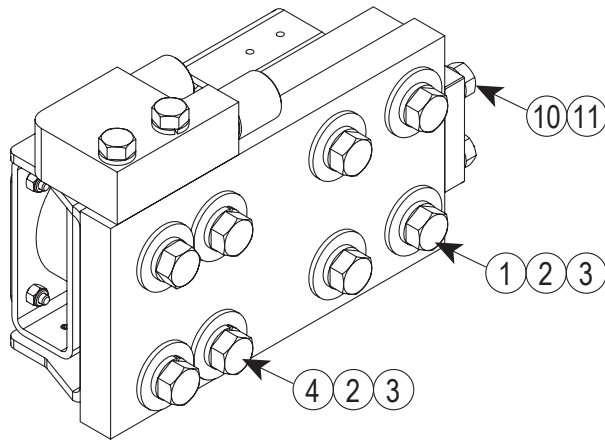
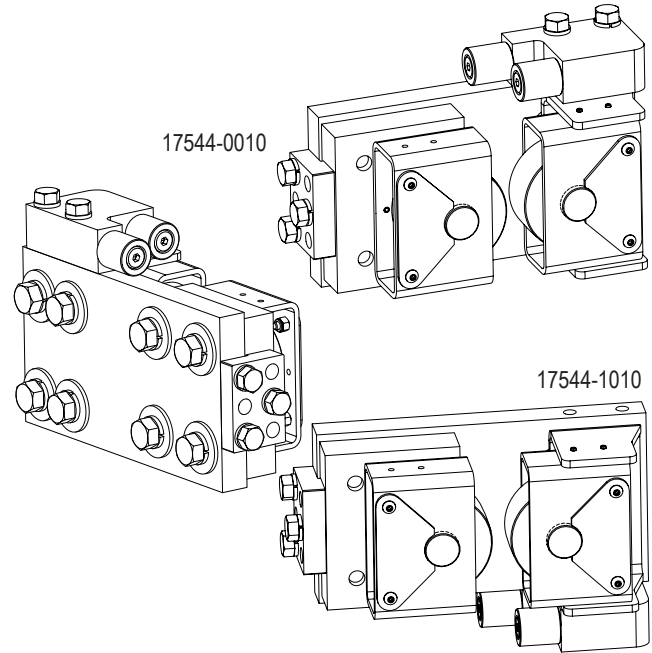
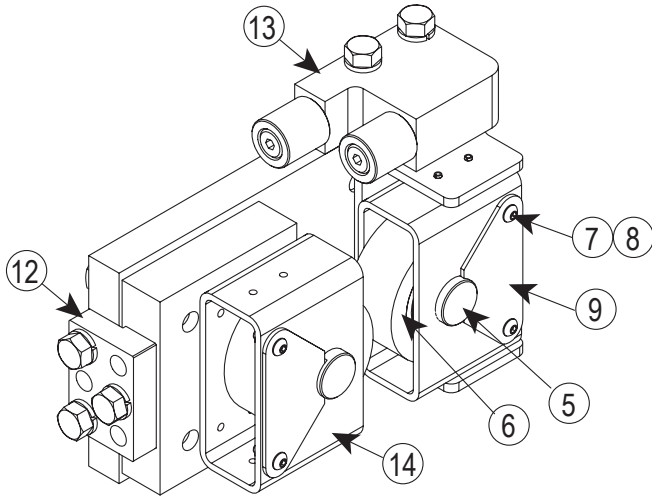

Item	Qty	Part No.	Description
1	4	6758-0036	Screw, HHC, 5/8-11 x 2.25, GR5
2	8	5858-0015	Lock Washer, Std, 5/8
3	8	6296-0015	Washer, Std, Flat, 5/8
4	4	7278-0024	Screw, HHC, 5/8-11 X 1.5, GR5
5	2	17546-0000	Pin, 30mm
6	2	17376-0000	Wheel, Polyurethane, 3.5 x 1.5
7	4	2888-0012	Screw, BHSC, 1/4-20 x 3/4
8	4	6708-0009	Nut, Lock, Nylon, 1/4-20
9	2	17545-0000	Plate, Retainer
10	3	9237-0024	Screw, HHC, 1/2-13 x 1.5, GR5
11	3	5858-0013	Lock Washer, Std, 1/2
12	1	17561-0000	Bar Clamp
13	1	17840-0000	Guide Roller Block Assembly
14	1	17543-0100	Polyurethane Wheel Assembly

Twin Roller Guide Wheelblock Assembly

RH - 17544-0020

Steel Wheels

LH - 17544-1020

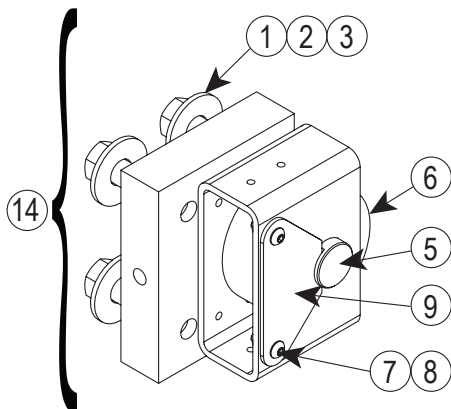
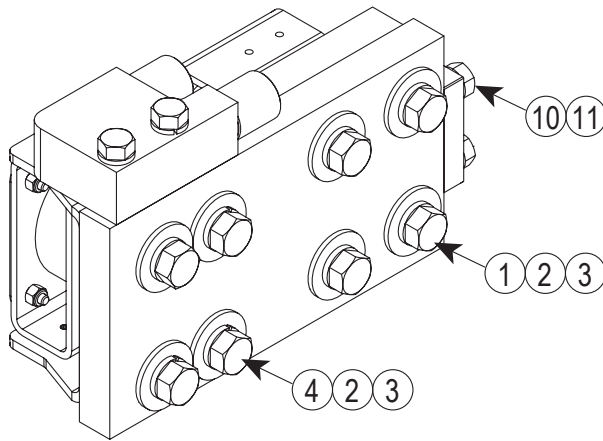
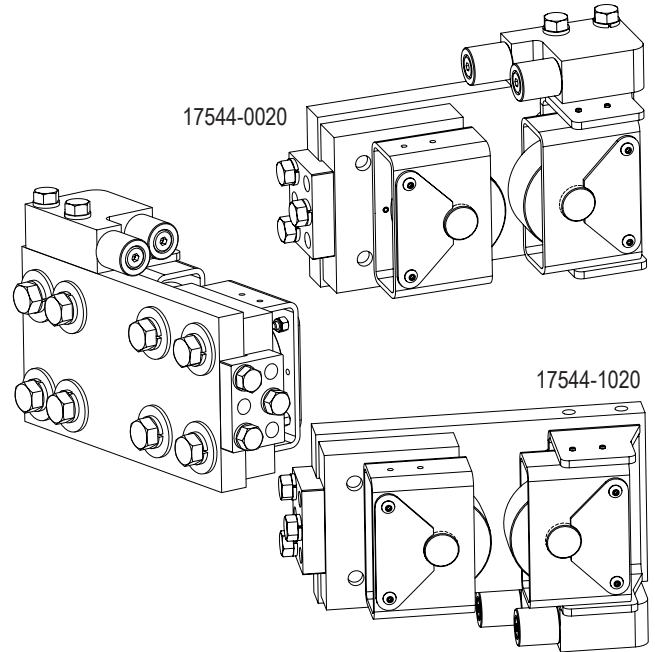
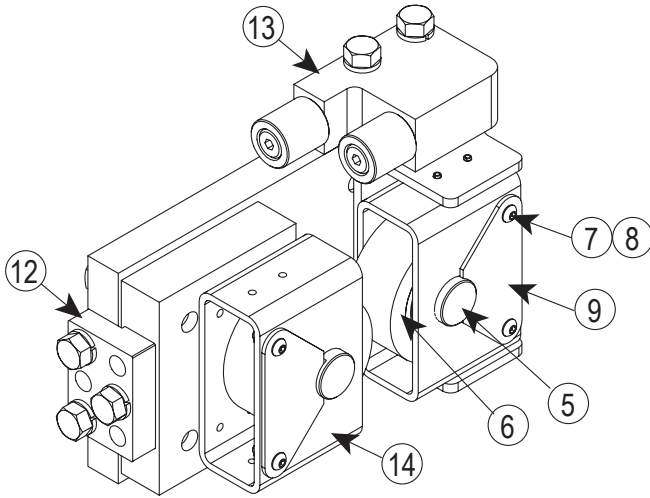

Item	Qty	Part No.	Description
1	4	6758-0036	Screw, HHC, 5/8-11 x 2.25, GR5
2	8	5858-0015	Lock Washer, Std, 5/8
3	8	6296-0015	Washer, Std, Flat, 5/8
4	4	7278-0024	Screw, HHC, 5/8-11 X 1.5, GR5
5	2	17546-0000	Pin, 30mm
6	2	17381-0000	Wheel, Steel, 3.5 x 1.5
7	4	2888-0012	Screw, BHSC, 1/4-20 x 3/4
8	4	6708-0009	Nut, Lock, Nylon, 1/4-20
9	2	17545-0000	Plate, Retainer
10	3	9237-0024	Screw, HHC, 1/2-13 x 1.5, GR5
11	3	5858-0013	Lock Washer, Std, 1/2
12	1	17561-0000	Bar Clamp
13	1	17840-0000	Guide Roller Block Assembly
14	1	17543-0200	Steel Wheel Assembly

Single Roller Guide Wheelblock Assembly RH Upper - 17541-0000

Nyloil Wheels (green)

LH Upper - 17541-1000

RH Lower - 17542-0000

LH Lower - 17542-1000

Note: Apply moly coat grease to inside diameter of wheel prior to inserting pin.

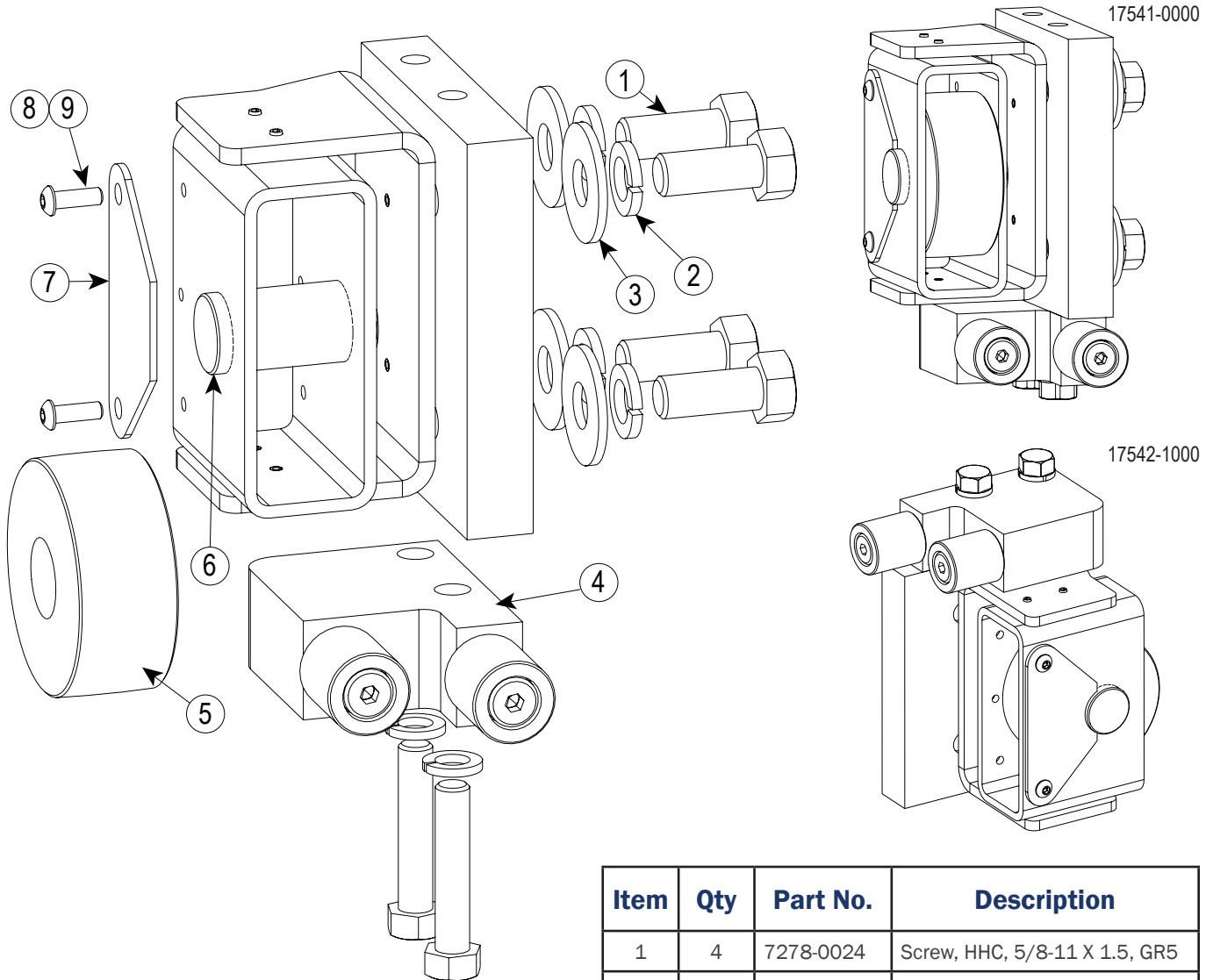

Item	Qty	Part No.	Description
1	4	7278-0024	Screw, HHC, 5/8-11 X 1.5, GR5
2	4	5858-0015	Lock Washer, Std, 5/8
3	4	6296-0015	Washer, Std, Flat, 5/8
4	1	17840-0000	Guide Roller Block Assembly
5	1	17548-0000	Wheel, Nyloil, 3.5 x 1.5
6	1	17546-0000	Pin, 30mm
7	1	17545-0000	Plate, Retainer
8	2	2888-0012	Screw, BHSC, 1/4-20 x 3/4
9	2	6708-0009	Nut, Lock, Nylon, 1/4-20

Single Roller Guide Wheelblock Assembly **RH Upper - 17541-0100** **Polyurethane Wheels (red)**
LH Upper - 17541-1100
RH Lower - 17542-0100
LH Lower - 17542-1100

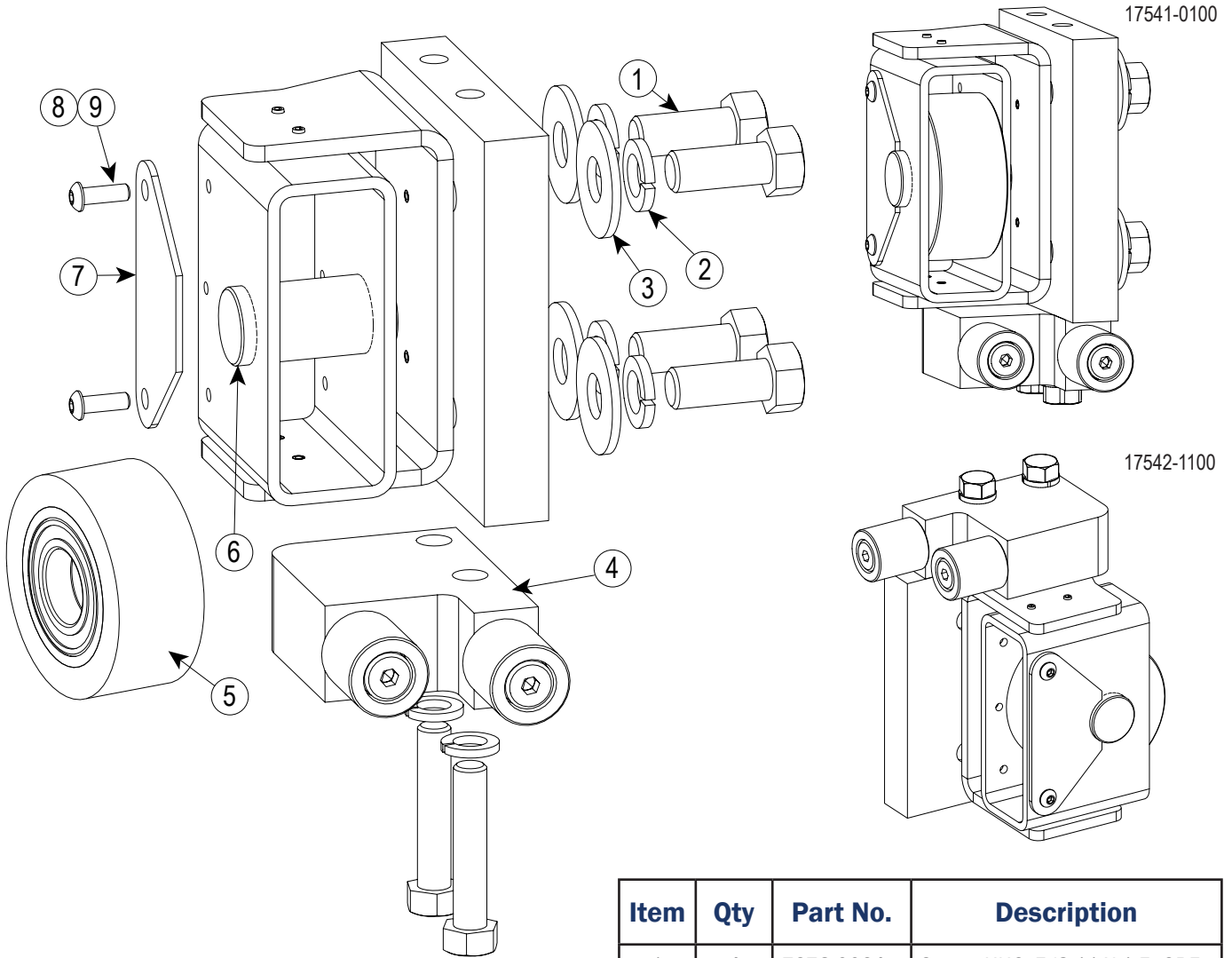

Item	Qty	Part No.	Description
1	4	7278-0024	Screw, HHC, 5/8-11 X 1.5, GR5
2	4	5858-0015	Lock Washer, Std, 5/8
3	4	6296-0015	Washer, Std, Flat, 5/8
4	1	17840-0000	Guide Roller Block Assembly
5	1	17376-0000	Wheel, Polyurethane, 3.5 x 1.5
6	1	17546-0000	Pin, 30mm
7	1	17545-0000	Plate, Retainer
8	2	2888-0012	Screw, BHSC, 1/4-20 x 3/4
9	2	6708-0009	Nut, Lock, Nylon, 1/4-20

Single Roller Guide Wheelblock Assembly **RH Upper - 17541-0200**
LH Upper - 17541-1200
RH Lower - 17542-0200
LH Lower - 17542-1200

Steel Wheels

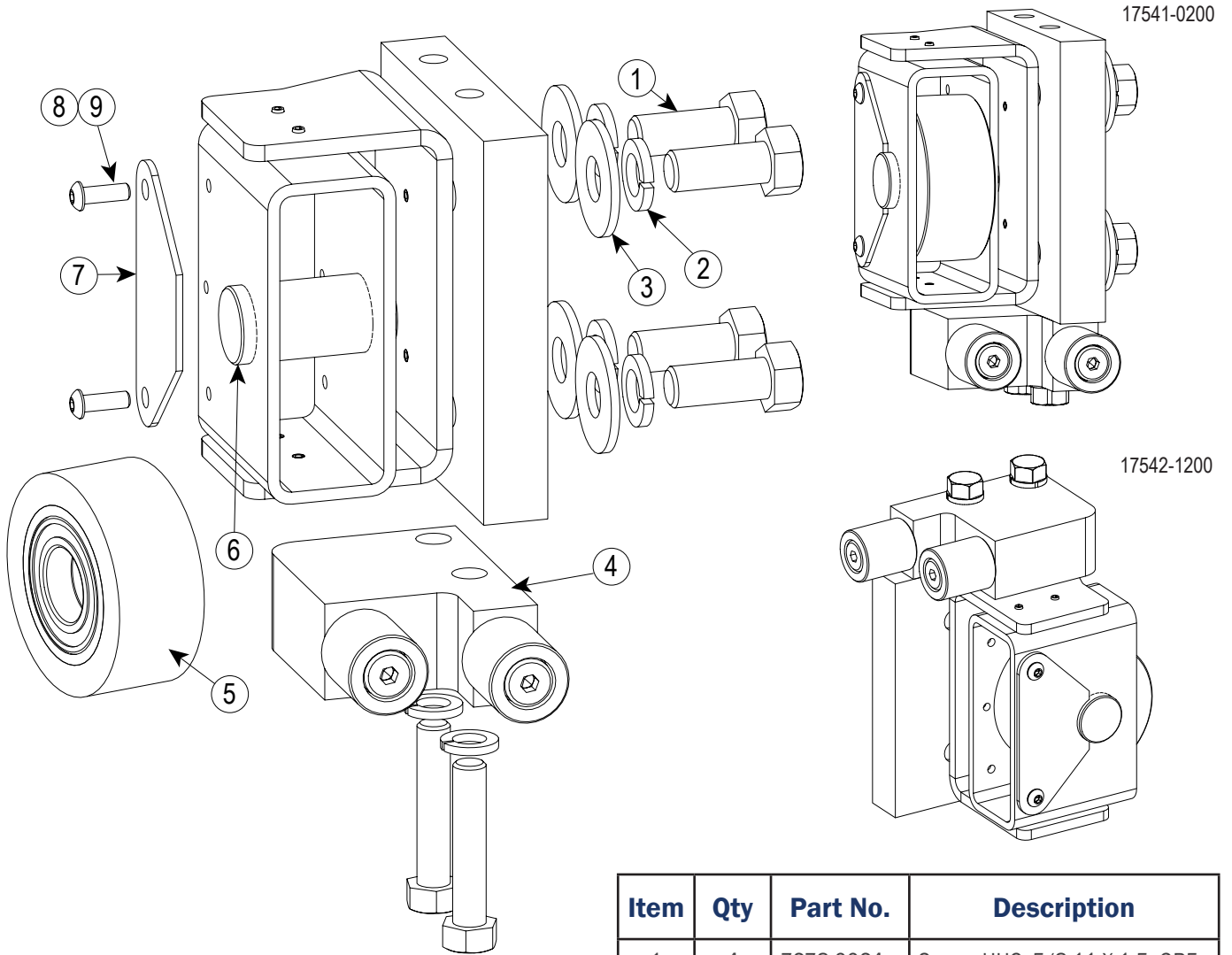

Item	Qty	Part No.	Description
1	4	7278-0024	Screw, HHC, 5/8-11 X 1.5, GR5
2	4	5858-0015	Lock Washer, Std, 5/8
3	4	6296-0015	Washer, Std, Flat, 5/8
4	1	17840-0000	Guide Roller Block Assembly
5	1	17381-0000	Wheel, Steel, 3.5 x 1.5
6	1	17546-0000	Pin, 30mm
7	1	17545-0000	Plate, Retainer
8	2	2888-0012	Screw, BHSC, 1/4-20 x 3/4
9	2	6708-0009	Nut, Lock, Nylon, 1/4-20



Environment

All components should be **stored indoors**. The area of storage should be kept at a constant temperature above 55° F (13° C) and relative humidity of approximately 40%, free from heavy dust and contaminants

NOTICE

Outdoor storage is **not** recommended. Our warranty policy does not cover damage as a result of improper storage.

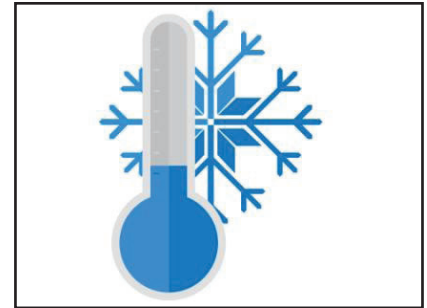

Avoid Cold Temperatures Figure 18-1

Stacking

Except for placing the parts container (crate) and bracing on the empty carriage, stacking of the various gate components is strictly forbidden. Enclosure and gate panels will warp. Objects stacked on top of the columns, drivebase assembly and/or hydraulic cylinders may cause severe damage. See Figure 18-2.

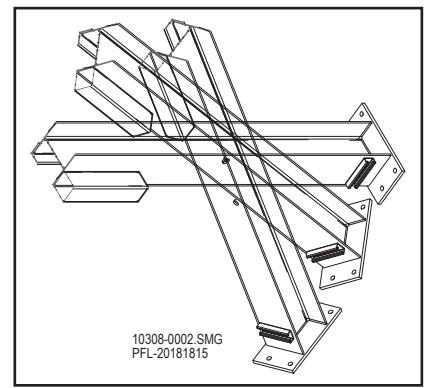

Do Not Stack Components Figure 18-2

Long Term Storage

Storage for more than two months after shipment, will require that the following maintenance procedures be performed every sixty days from date of shipment:

1. If **roller chains** are stored for an extended period of time or in a corrosive environment, they must be dipped or stored in a non-detergent oil to retain their original condition.
2. Lightly coat the **sprockets** with a non-detergent oil to prevent corrosion.
3. Lubricate the **safety cams** with a non-detergent oil and rotate to make sure the safety cams move freely. See Figure 18-3.
4. Elevate the **drivebase assemblies** off the ground and cover with a tarp. Allow adequate ventilation to minimize condensation. Protect all exposed or unpainted shaft and flange surfaces with an anti-corrosion agent or grease. Store in a location free from shock and vibration, to avoid false brinelling of the bearing elements and raceways.

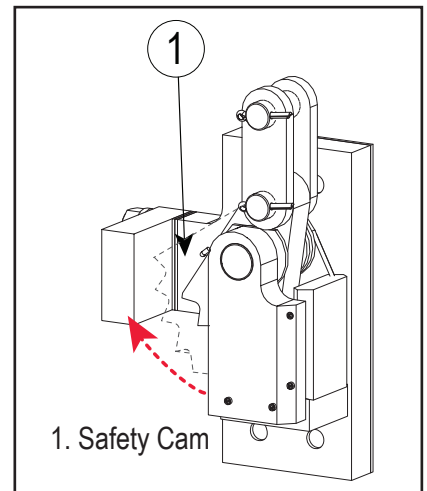

Lubricate and Rotate Safety Cam Figure 18-3

Long Term Storage
(continued)

 **DANGER**



High Voltage! Employees servicing or maintaining VRCs may be exposed to death or serious personal injury if hazardous energy is not properly controlled. Follow your facilities procedures or OSHA lockout/tagout (LOTO) procedures anytime maintenance or service is being performed on any electrical box or component. Only qualified and trained service technicians are to apply power to the motor.

 **CAUTION**

The incoming voltage source must match the voltage identified on the rating tag. The rating tag provides essential technical information required for any installation, maintenance, or repairs. Do not remove, damage, or modify the rating tag.

NOTICE

A qualified person is defined as a person who, by possession of a recognized degree or certificate of professional standing, or by extensive knowledge, training, and experience, has successfully demonstrated his/her ability to solve problems relating to the subject matter and work.

5. Rotate the drivebase shaft. **Apply power** to the motor/brake with the correct voltage and correct brake wiring configuration with the vent plug installed in the reducer. This will rotate the drive shaft and cycle the brake once. **Manually cycle the brake** several times using the lever on the side of the motor. After rotating with temporary power, remove the vent plug and install the original plug to prevent contamination of the reducer oil. Before initial use, drain and replace the reducer oil.
6. Apply lithium-type grease to the **pillow block and bearings**. Wrap or trap the pillow blocks to avoid exposure to contaminants if needed.
7. Plug the **electrical component** inlets to prevent moisture and other contaminants from entering them. Store in a dry, temperature controlled location to prevent corrosion. Place silica gel desiccant inside the control enclosure. Inspect the inside of the control enclosure for any moisture build up. See Figure 18-4.
8. Make sure the **parts crate** remains sealed and dry.



Place Inside Control Enclosure
Figure 18-4

Storage for Longer
than Six Months

For units stored longer than six months, it is recommended that you contact the PFlow Industries, Inc. Customer Support Department for additional information that may be available prior to starting up your unit.

Equipment Manuals

The VRC installation manual, electrical, and owner's manuals are located in the parts container (crate). Do not open the parts container (crate). If the manuals are required, contact the PFlow Industries, Inc. Customer Support Department for an electronic copy (.pdf).



Before You Begin

Read this entire manual.

Purpose

The PFlow Industries, Inc. Vertical Reciprocating Conveyor (VRC) is designed for the movement of materials only, up to the VRC's rated capacity, from one level to the next. Passengers are not allowed. The placement of capacity labels, and safety warnings are the installer's responsibility. Make sure the warning labels are placed on each gate and each push-button station.

PFlow Industries, Inc. supplies the appropriate signage in a manila envelope in the parts crate with the original shipment. Contact PFlow Industries, Inc. Customer Support Department for signage if another language is needed.

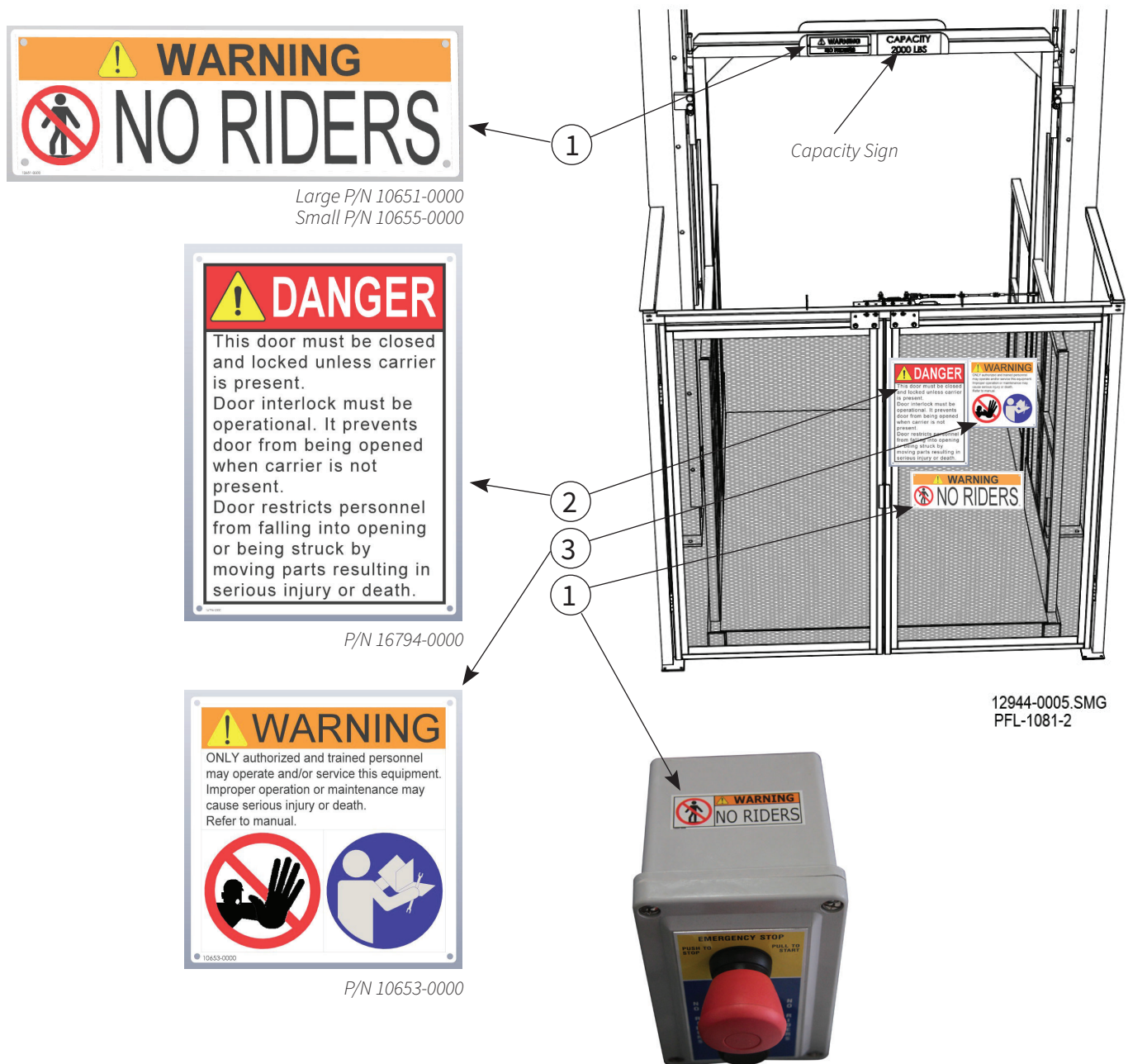

Section 19 | Signage Locations



MATERIAL HANDLING SOLUTIONS

www.pflow.com
P 414 352 9000
F 414 352 9002
6720 N. Teutonia Ave.
Milwaukee, WI 53209



Installation Questionnaire



MATERIAL HANDLING SOLUTIONS

www.pflow.com
 P 414 352 9000
 F 414 352 9002
 6720 N. Teutonia Ave.
 Milwaukee, WI 53209

Thank You

PFlow Industries, Inc. would like to thank you for the opportunity to serve you. Your business is appreciated. Please help us to ensure that your expectations are met by taking a few minutes to tell us about the equipment and service that you have received. Complete the Installation Questionnaire and Acceptance Certificate. Return both forms to PFlow Industries, Inc. via e-mail to csd@pflow.com. Additional space for comments is available on the next page.

Yes ✓ No ✓

Product Perception

Was the equipment shipment complete as expected?		
What items were missing, if any?		

Was the equipment in good condition?		
Describe the equipment damage or concerns with the workmanship, if any.		

Did the equipment match the General Arrangement (GA) drawing?		
Was the equipment dimensionally correct with form, fit, and function?		
Describe any problem areas in detail.		

Electrical Installation

Was the electrical field wiring completed as required?		
Were there any issues with the electrical components?		
After the electrical installation was completed, was it necessary to return for final adjustments, testing, and training?		
Were you made aware of any electrical problems?		
Describe any "No" answers in detail.		

Testing

Was the equipment tested at full load capacity?		
Were all gates tested to ensure proper operation and interlock operation?		

PFlow Serial Number	Customer/User	Date
Questionnaire Completed by	E-mail Address	
Company	Phone Number	

Installation Questionnaire



MATERIAL HANDLING SOLUTIONS

www.pflow.com
P 414 352 9000
F 414 352 9002
6720 N. Teutonia Ave.
Milwaukee, WI 53209



Acceptance Certification



MATERIAL HANDLING SOLUTIONS

www.pflow.com
 P 414 352 9000
 F 414 352 9002
 6720 N. Teutonia Ave.
 Milwaukee, WI 53209

Acceptance

We, the Customer, accept the equipment listed below as being properly installed, tested, and performing to our satisfaction. This form covers both the mechanical and the electrical installation of the equipment. This acceptance in no way releases either PFlow Industries, Inc. or the installing contractor(s) of any warranty obligations. If there are any exceptions or unresolved items, please include detailed information.

PFlow Serial Number:	Model Number:	<input type="checkbox"/> B	<input type="checkbox"/> D	<input type="checkbox"/> DB	<input type="checkbox"/> F	<input type="checkbox"/> M	<input type="checkbox"/> 21	Other _____
Job Name:								
Site Street Address:								
Site Mailing Address:								
Site City:						State:		Zip Code:
Customer Contact Name:						Contact Title:		
Customer Contact Phone: ()						Ext		E-Mail:

Tests Performed	Load Capacity:				Start-up Date:
	Load Test:	<input type="checkbox"/> Yes	<input type="checkbox"/> No	at ____ % of lift capacity	Customer Initials:
	Operation Test:	<input type="checkbox"/> Yes	<input type="checkbox"/> No		Comments:
	Gate/Interlock Operation:	<input type="checkbox"/> Yes	<input type="checkbox"/> No	<input type="checkbox"/> Not Applicable	
	Other Test:				
	Other Test:				

Personnel Instructed on the Operation and Preventive Maintenance:	
Name:	Company:
Name:	Company:

Accepted by:	Acceptance Date:
Name/Phone:	PFlow Rep Present:
Title:	Name:
Company:	Company:

Please return a copy of this form to the PFlow Industries, Inc. Customer Support Department at csd@pflow.com.

Acceptance Certification



MATERIAL HANDLING SOLUTIONS

www.pflow.com
P 414 352 9000
F 414 352 9002
6720 N. Teutonia Ave.
Milwaukee, WI 53209

