



---

## **F Series | Mechanical VRC 4-Post**

---

### **Owner's Manual with Eurodrive Motor**

#### **Important:**



**Read this entire manual.  
Important safety information  
is included.**

The illustrations depicted in this manual are not to scale or detail. The illustrations are for reference only.

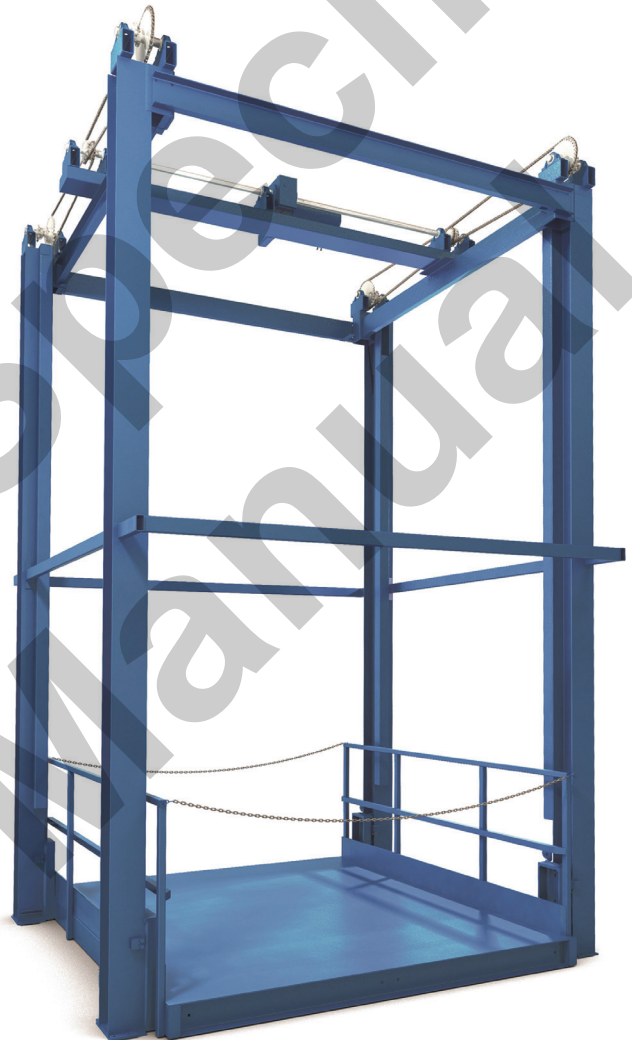



Description		Section   Page
<b>1. Contact Information</b>	15705-0011	1   1
<b>2. General Information</b>	15710-0004	2   1
Introduction		2   1
General Overview		2   1
Code Requirements		2   1
Parts		2   1
Service		2   1
Feedback		2   1
<b>3. Warranty Information</b>	15710-0014	3   1
Parts and Labor		3   1
Definitions		3   1
Warranty		3   1
Exclusions		3   1
Obligation		3   1
Liability		3   2
Warranty Procedures		3   2
Pre-Authorization		3   2
Invoices		3   2
<b>4. Important Safety Information</b>	15708-0200-01	4   1
Read the Entire Manual		4   1
Intended Purpose		4   1
Potential Risks and Possible Misuse		4   1
Safety Alert Symbols		4   1
Danger Statements		4   2
Warning Statements		4   2
Caution Statements		4   4
Electrical Safety Precautions		4   5
De-energize the Circuit		4   5
Electrical Safety Precautions		4   6
Working on Energized Circuits		4   6
Notes for the Installation Electrician		4   6
Entrance Below a Raised Carriage Deck	15709-0083	4   7
<b>5. Glossary</b>	15710-0018	5   1
Unique Descriptions and Names		5   1
Gate Types		5   8
Identifying Call Outs		5   9



Description		Section   Page
<b>6. Electrical Standards and Definitions</b>	15709-0085	6   1
Field Electrical Wiring Standards		6   1
Definitions		6   1
Requirements		6   1
Electrical Ruling Bodies		6   2
PFlow's Standard		6   2
Outdoor Application		6   2
Corrosive Application		6   2
Hazardous Location		6   3
Class Definitions		6   3
Division Definitions		6   3
Group Designations		6   3
<b>7. Mechanical Overview</b>	15704-1008	7   1
Lift Columns		7   1
Drivebase Assembly		7   2
Safety Cam and Wheelblock		7   3
Lift Chains		7   4
Safety Cam Function		7   5
Enclosures		7   6
Gate Assemblies		7   7
<b>8. Electrical Overview</b>	15704-0009	8   1
Main Control Panel		8   1
Push-Button Stations		8   1
Main Disconnect Switch		8   1
Drivebase Assembly		8   2
Limit Switches		8   2
<b>9. Sequence of Operation</b>	15704-1015	9   1
Important Safety Information		9   1
Sequence		9   2
To Operate the Lift		9   5



Description		Section   Page
<b>10. SEW Eurodrive Motor Identification</b>	15705-8010	10   1
Safety Information		10   1
DRN Gearmotor Labeling		10   2
Code Definitions		10   2
DRN Motor Labeling		10   3
Code Definitions		10   3
Motor Options and Nomenclature		10   4
Motor Option Codes		10   4
Activate Breather Valve		10   5
Confirm the Oil Level		10   5
Brake Running Operation		10   6
<b>11. SEW Eurodrive Motor Maintenance and Troubleshooting</b>	15705-8011	11   1
Safety Information		11   1
Brake Running Operation		11   2
Brake Maintenance		11   2
Air Gap Values		11   3
Adjust the Air Gap		11   4
Troubleshooting the Motor		11   5
Troubleshooting the Brake		11   6
Removing the Brake		11   7
Disposal of the Brake and Gearmotor		11   7
Gear Unit Lubrication		11   8
Lubricant Replacement		11   8
Maximum Oil Temperature		11   8
Lubrication Notes		11   9
Oil Volume		11   9
Changing the Oil		11   9
Oil Plug Connections		11   10

# Table of Contents



**MATERIAL HANDLING SOLUTIONS**

www.pflow.com  
 P 414 352 9000  
 F 414 352 9002  
 6720 N. Teutonia Ave.  
 Milwaukee, WI 53209

Description		Section   Page
<b>12. Cleaning</b>	15709-0088	12   1
Important Safety Information		12   1
Cleaning		12   1
<b>13. Preventive Maintenance and Schedule Checklist</b>	15704-1014	13   1
Important Safety Information		13   1
Checklist		13   2
<b>14. Troubleshooting</b>	15705-0021	14   1
<b>15. Adjust Overcurrent Sensor</b>	15709-0052	15   1
<b>16. Recommended Spare Parts</b>	15704-1013	16   1
<b>17. Parts</b>	15704-1016	17   1
Drivebase Assembly		17   1
Chain Arrangement		17   2
Chain Tensioner Assembly		17   3
Drive Chain Tension Sensor Assembly		17   4
Interlocks		17   5
Gate Status Switches		17   7
Safety Cam Assembly		17   8
Guide Roller Block Assembly		17   9
Twin Roller Guide Wheelblock Assembly		17   10
<b>18. Recommended Storage Requirements</b>	15709-0080	18   1
Stacking		18   1
Long Term Storage		18   1
Storage for Longer than Six Months		18   2
Equipment Manuals		18   2
<b>19. Signage Locations</b>	15709-0035	19   1
<b>Installation Questionnaire</b>	15708-1500	Forms   1
<b>Acceptance Certificate - VRC</b>	15710-0017-VRC	Forms   1

# Table of Contents



**MATERIAL HANDLING SOLUTIONS**

[www.pflow.com](http://www.pflow.com)  
P 414 352 9000  
F 414 352 9002  
6720 N. Teutonia Ave.  
Milwaukee, WI 53209





PFlow Industries, Inc.  
6720 N. Teutonia Avenue  
Milwaukee, Wisconsin 53209



Office  
Phone: 414-352-9000  
Fax: 414-352-9002



Customer Support Department  
e-mail: [csd@pflow.com](mailto:csd@pflow.com)



Sales  
e-mail: [sales@pflow.com](mailto:sales@pflow.com)

For a list of contact personnel visit the PFlow Industries, Inc. website at:  
<https://www.pflow.com/contact>

---

## Documentation

PFlow Industries, Inc. reserves the right to make changes or improvements to the standard model line at any time. PFlow Industries, Inc. reserves the right to make changes to subsequent editions of the manual without prior notice to holders of this edition.

---

## Copyright Notice

© Copyright February 2024 by PFlow Industries, Inc.

All rights reserved.

No part of this manual may be reproduced or used in any form without expressed written permission from PFlow Industries, Inc.

This publication may be photocopied by the original purchaser. Any other type of reproduction is prohibited without express written permission from PFlow Industries, Inc.

---

## Trademarks

All trademarks referenced in this manual are the property of their respective owners.

---

## System Modifications/Disclaimer

Mechanical or electrical modifications performed on the equipment not approved by PFlow Industries, Inc. may void any warranty and/or service agreements. Please contact the PFlow Customer Support Department for assistance with service modifications.

---

## Training

Training is available upon request from the Customer Support Department. Half-Day, Full-Day, and Two-Day sessions are customized to fit specific needs - either for a single equipment type or for the entire product line.

---

## On-site Supervision

On-site supervision services are available from the Field Service Department. Contact our Field Service Manager for more details.

---

## Source Language

This manual is written in American English.

---

## Section 1 | Contact Information



**MATERIAL HANDLING SOLUTIONS**

[www.pflow.com](http://www.pflow.com)  
P 414 352 9000  
F 414 352 9002  
6720 N. Teutonia Ave.  
Milwaukee, WI 53209







---

<b>Introduction</b>	This manual provides information about the PFlow Industries, Inc. custom designed Vertical Reciprocating Conveyor (VRC). As the nations' leading manufacturer of vertical material handling equipment, PFlow Industries, Inc. is confident that this new VRC will provide many years of reliable service.
<b>General Overview</b>	The VRC provides a safe and simple means of moving material from one level to another. The simplicity of design and few moving components ensure a trouble-free, long life, with low maintenance and little downtime.
<b>Code Requirements</b>	<b><i>This VRC is designed for the movement of materials only, up to the VRC's rated capacity, from one level to the next. Do not allow anyone to ride on the VRC.</i></b> VRCs are <b>not</b> elevators, and are specifically excluded within the scope of the ASME A17.1 Safety Code for Elevators and Escalators. VRCs are included in ASME B20.1 Safety Standard for Conveyors and Related Equipment, which is incorporated by reference into OSHA 29 CFR 1910. A copy of the ASME B20.1 standard can be purchased at <a href="http://www.asme.org">www.asme.org</a> and other sources. PFlow Industries, Inc. recommends that this standard be referenced for appropriate installation, maintenance, inspection, and operation in relation to hazards. All electrical designs and components are in accordance with National Electric Code (NEC) requirements. Local codes may require initial inspection of the installation and periodic inspection and testing of the unit. Contact PFlow Industries, Inc. for more information in the event an inspection is required.
<b>NOTE</b>	<i>The information and illustrations in this manual are intended only as an aid to understanding the VRCs general installation. The information and illustrations do not cover every possible contingency or circumstance regarding nonstandard options or site conditions.</i>
<b>Parts</b>	If there is a problem, call PFlow Industries, Inc. at (414) 352-9000, during normal business hours, 8:30 a.m. to 5:00 p.m. central standard time, Monday through Friday. Outside of those hours, see the PFlow Industries, Inc. Contact Information page for additional information. Use the model number and serial number or the PFlow Industries, Inc. General Arrangement (GA) drawing number for the lift in all correspondence.  Equipment damage resulting from modification in any manner from the original model, including the substitution of parts other than factory authorized parts, will void the warranty. Furthermore, PFlow Industries, Inc. will not be liable for any loss, injury, or damage to persons or property, nor for direct, indirect, or consequential damage of any kind resulting from modified or substitution of parts other than factory authorized parts of said material or equipment.  PFlow Industries, Inc. maintains a complete stock of, or has access to, all replacement components. Detailed records of all equipment sold are kept. If a component is damaged in shipment, is defective or missing, contact PFlow Industries immediately.
<b>Service</b>	The PFlow Industries, Inc. Customer Support Department will assist maintenance and service personnel with any questions or problems regarding the equipment or installation.
<b>Feedback</b>	Your feedback is important. Please help PFlow Industries, Inc. understand if the equipment has met your expectations. Please complete the questionnaire in this manual. The questionnaire will help us address any comments and/or concerns.

## Section 2 | General Information



**MATERIAL HANDLING SOLUTIONS**

[www.pflow.com](http://www.pflow.com)  
P 414 352 9000  
F 414 352 9002  
6720 N. Teutonia Ave.  
Milwaukee, WI 53209





**Parts and Labor**

<b>Parts:</b>		<b>Labor:</b>	
Structure	Lifetime	Structure	Lifetime
Manufactured Components	1 Year	Manufactured Components	1 Year
Purchased Components	1 Year	Purchased Components	Supplier
Gates and Enclosures	90 Days	Gates and Enclosures	90 Days

**Definitions**

- Structure is defined as columns, carriage, and pre-fabricated bracing (excluding carriage side guards).
- Manufactured components are defined as those components manufactured by PFlow Industries, Inc.
- Purchased components are those components that are used as supplied by vendors and covered by the Supplier’s labor warranty.

**Warranty**

PFlow Industries, Inc. expressly warrants to the original purchaser that this product will be free from defects in material and workmanship under normal, intended use. The warranty period begins 60 days after shipment.

**Exclusions**

This warranty does not apply to:

1. Equipment or components damaged or broken in transit or shipping.
2. Replacement of wear parts.
3. Equipment failures caused by abuse, misuse, exceeding recommended capacities, impact with other objects, negligence, improper installation, unskilled use, unskilled maintenance, inadequate maintenance, or incorrect adjustments.
4. Exposure to a corrosive or abrasive environment or exterior elements unless specifically built for that environment.
5. Equipment that has been repaired, altered or modified in any manner outside of the manufacturing facility, substitution of parts other than factory authorized parts, removal of any parts, or addition of any parts without prior written permission by PFlow Industries, Inc.
6. Any losses or damages resulting from loss of data, loss of revenue or profits, loss of products, incidental or consequential damages, delays, or expenses incurred by failure of said part or parts even if advised of the possibility thereof.
7. Lost time and/or additional trips for missing or damaged components.
8. Expedited freight charges.

**Obligation**

The obligation for PFlow Industries, Inc. is limited to only the replacement or repair of defective components that received prior authorization. This is the owner’s sole remedy.

PFlow Industries, Inc. will bear normal labor charges performed by an authorized PFlow Industries, Inc. service agent during standard business hours, excluding overtime, holiday rates, or any additional fees.

This warranty applies to all models and no person except an officer of PFlow Industries, Inc. is authorized to modify this warranty or to incur on behalf of PFlow Industries, Inc. any other obligation or liability in connection with PFlow Industries, Inc. equipment.



**Liability**

PFlow Industries, Inc. believes, to the best of our knowledge, that the information in the equipment manuals are accurate. In the event that technical or typographical errors exist, PFlow Industries, Inc. reserves the right to make changes to subsequent editions of the manual without prior notice to holders of this edition. The reader should consult PFlow Industries, Inc. if errors are suspected.

The customer’s right to recover damages caused by fault or negligence on the part of PFlow Industries, Inc. shall be limited to the amount paid to PFlow Industries, Inc. by the customer. The limitation of liability of PFlow Industries, Inc. will apply regardless of the form of action, whether in contract or tort, including negligence. Any action against PFlow Industries, Inc. must be brought within one (1) year after that cause of action accrues.

PFlow Industries, Inc. will not be liable for any loss, injury, or damage to persons or property, nor for direct, indirect, or consequential damage of any kind resulting from failure or defective operation of said material or equipment.

**Warranty Procedures**

All billing must be in accordance with our Warranty Procedures. Replacement of defective parts will be handled in accordance with the Return Materials Authorization (RMA) policy for PFlow Industries, Inc.

**Pre-Authorization**

- All warranty work must be pre-authorized by PFlow Industries, Inc. Customer Support Department prior to starting work.
  - Where distance and or experience may be more cost-effective, PFlow Industries, Inc. reserves the right to use alternate organizations.
  - Labor is defined as a maximum of two hours travel per call, plus reasonable on-site repair time as determined by PFlow Industries, Inc.
  - Local purchase of components must be pre-authorized.
1. Notify the PFlow Industries, Inc. Customer Support Department of the problem for authorization.
  2. PFlow Industries, Inc. will determine:
    - The cause of the problem.
    - Who will do the repair work.
    - The repair details involved.
  3. If PFlow Industries, Inc. decides that your organization or your subcontractor will do the work, an authorization number will be assigned which must be referenced on all subsequent paperwork.

**NOTE** *Notify PFlow Industries, Inc. by phone, FAX, or e-mail during the next business day if an event occurs during our non-working hours. Issuance of an authorization number does not guarantee approval and/or payment.*

**Invoices**

1. Submit an invoice for approval within 30 days after the date the work was completed. Payment is made 30 days after the date of approval.
2. A deduction from outstanding payments to PFlow Industries, Inc. for warranty is never authorized.
3. Invoices received without sufficient information will be returned. Invoices will be reconsidered for approval when complete documentation is received. All invoices must include, in detail, the following:

<input type="checkbox"/> PFlow serial number.	<input type="checkbox"/> Labor hours expended resolving the problem.
<input type="checkbox"/> Date the work was performed.	<input type="checkbox"/> Rates per hour.
<input type="checkbox"/> Description of the problem.	<input type="checkbox"/> Copies of receipts for materials purchased.
<input type="checkbox"/> Travel time incurred.	<input type="checkbox"/> Detailed description of work completed.



**Read the Entire Manual**

Important: Carefully read the entire manual upon receipt of the VRC. Improper installation, alteration, adjustment, service, cleaning, or maintenance could result in death, severe injury, or property damage. Instructions and warnings must be read and thoroughly understood by all operators and users. PFlow Industries, Inc. recommends that the owner conduct regular staff training including safety instructions on a regular basis to avoid the risk of accident or damage to the VRC.

Following procedures other than those indicated in this guide to install, use, and maintain the VRC is considered inappropriate and may cause fatal accidents, personal injury, or property damage, in addition to invalidating the warranty.

**Intended Purpose**

The intended purpose of the PFlow Industries, Inc. Vertical Reciprocating Conveyor (VRC) is to provide a safe and simple means of moving materials only, up to the VRCs rated capacity, from one level to another. VRCs are **not** elevators. The VRC is exclusively intended for use in establishments where all operators have been trained to understand the purpose, limitations, and associated hazards of the VRC. Any other use is strictly forbidden.

**Potential Risks and Possible Misuse**

PFlow Industries, Inc. has attempted to protect against as many hazards as possible. The following potential risks should be addressed before the VRC is put into operation:

- Risk of injury caused by falling products.
- Risk of injury caused by product extending beyond the confines of the carriage.
- Risk of injury caused by exceeding the weight capacity of the VRC.
- Hazards occurring at places where the VRC connects to incoming and outgoing conveyors.
- Risk of injury if any safety features are bypassed.
- Risk of injury due to the use of corrosive chemicals or water jet.

**Safety Alert Symbols**

To ensure your safety and the safety of those around you, it is important that you read, observe, and understand ALL safety precautions relative to a particular task. Safety precautions in the manual are labeled with an alert symbol followed by the word **DANGER**, **WARNING**, or **CAUTION**.



This is the safety alert symbol. It is used to alert you to potential physical injury hazards. Obey all safety messages that follow this symbol to avoid possible injury or death.



Indicates a hazardous situation that, if not avoided, will result in death or serious injury.



Indicates a hazardous situation that, if not avoided, could result in death or serious injury.



Indicates a hazardous situation that, if not avoided, could result in minor or moderate injury.

**NOTICE**



Used to address practices not related to physical injury.







 **DANGER**

- Stay within the rated lift capacity.
- Make sure all safety devices are in place and operable before using the equipment. If any safety device is missing or inoperable, immediately remove the equipment from service.
-  High Voltage! A qualified electrician must install all electrical connections and permanent wiring in accordance with applicable local or national electrical codes. Make sure the equipment is properly grounded in accordance with local electrical codes or, in the absence of local codes, with the current edition of the National Electrical Code NFPA No. 70.
- Falling column hazard! Make sure all beams, columns, posts, enclosure panels, and components are properly supported during installation. Illustrations may show the beams, columns, posts, enclosure panels, and components unsupported in order to make the equipment and installation instructions clearly understood.
- Keep clear of unsupported platforms. Stay out of the area under a raised platform. If a maintenance operation requires the carriage to remain in the raised position, refer to Bulletin 15709-0083 for additional information or contact PFlow Industries, Inc. Customer Support Department for assistance.

 **WARNING**

- This equipment can be dangerous if not used properly. Allow only competent adults who have been properly trained and authorized personnel to operate this equipment.
-  Passengers are not permitted. Riding may result in death or serious personal injury.
- This equipment must be maintained to ensure safety. Allow only properly trained personnel to service the equipment. Implement a routine safety inspection plan and follow the recommended preventive maintenance schedule in the owner's manual.
-  Lockout/tagout equipment before performing any adjustments or maintenance. If the equipment is not locked out, it could start unexpectedly and cause injury or damage. **Make sure all personnel are aware of the potential for stored energy to be present even after the power has been locked out.** Refer to ANSI Z244.1 and OSHA 29 CFR 1910.147 for minimum requirements for a lockout/tagout system. There may be additional state or local requirements.
-  Components and accessories may be heavy. To prevent serious injury, use the appropriate lifting apparatus when handling the components and installing the VRC.

### **WARNING**

- If any defects relating to operating safety and reliability are detected or if any damage occurs, the VRC must be taken out of operation immediately.
- Before the VRC is put into operation, all VRC parts must comply with all relevant health and safety directives and regulations.
- Do not switch the main power supply on or start the VRC when persons are in contact with the VRC.
-  Make sure that no persons or objects are within the range of any moving parts of the VRC.
-  Climbing, sitting, walking, or riding on equipment while the equipment is in operation could result in death or serious injury.
- If this VRC needs to be modified in any way, contact PFlow Industries, Inc. for assistance. Do not make any unauthorized changes.
-  **Falling Hazard!** Close all gates before the carriage is moved. Never leave the lift unattended with the gates in the open position. Never close gates when a person is on the carriage or within the fenced area.
- Place the load in the center of the carriage platform to avoid shifting loads. Lock rolling casters in place. Make sure that any portion of the load does not overhang the perimeter of the carriage. Prevent unstable load conditions.
- If the carriage deck does not stop after contact has been made with the limit switch arm, or continues to drift past the floor level, the lift motor brake is not working properly. Discontinue use of the VRC and contact PFlow Industries, Inc. for assistance.
-  Lockout/tagout the VRC before removing jammed product. Be aware that stored energy in the lift components may move or shift when the jam is removed. De-energize any circuit before work is begun.
- Do not overtravel! Stops, mechanical or electrical, must be in place to prevent the carriage from traveling beyond the intended floor level. Overtravel could cause permanent damage to the carriage or failure of the lifting mechanism.
-  **Entanglement hazard!** Secure long hair, wear snug-fitting clothing, and avoid wearing jewelry while using the VRC.



---

 **CAUTION**



- Inform personnel about the location and operation of emergency stops and power disconnection points.
  - During operation, the surfaces of some components may become hot. Avoid touching hot surfaces or wear protective gloves.
  - If any unsafe or unusual conditions are observed, stop the equipment and remove it from service. Report the condition to your supervisor.
-





Electrical Safety Precautions

 **DANGER**



High Voltage! Employees servicing or maintaining VRCs may be exposed to death or serious personal injury if hazardous energy is not properly controlled. De-energize any circuit before work is begun. Follow your facilities procedures or OSHA lockout/tagout (LOTO) procedures anytime maintenance or service is being performed on any electrical box or component.

 **CAUTION**

The incoming voltage source must match the voltage identified on the rating tag. The rating tag provides essential technical information required for any installation, maintenance, or repairs. Do not remove, damage, or modify the rating tag.

De-energize the Circuit

1. Lockout/tagout whenever any work, maintenance, or service is performed on any electrical box or component. Make sure circuits are de-energized before starting work, using a functional, properly rated, and well maintained multimeter or voltage sensing device. Make sure the device is rated for the level of voltage being measured and is sensitive enough for the application.
2. Use fuse pullers to change a fuse; **never** use bare hands, pliers, or screwdrivers.
3. Install covers on exposed electrical devices or wires to protect personnel from serious injury.
4. Ground all metal connection boxes, switch boxes, starting boxes, transformers, motors, limit switches, interlocks, and push-button stations to prevent shock to personnel.
5. When using a portable meter, never leave one lead dangling with the other lead connected. Anyone touching the lead may receive a shock through the meter.
6. Make sure that all is clear following lockout/tagout procedures before applying power to a circuit. This is necessary in order to protect personnel from injury and to prevent damage to the equipment.
7. Avoid accidental contact with equipment or conductors which are known to be energized or are **not** known to be de-energized. If it is necessary to work on equipment while it is energized, use extra care. Always test and repair equipment that appears damaged or delivers an electric shock.

Take time to be careful! Follow all safety precautions to prevent death or personal injury.

**Electrical Safety Precautions**

 **DANGER**



High Voltage! To prevent serious injury, death, or property damage, all electrical connections and permanent wiring must be installed by a licensed electrician in accordance with applicable local or national electrical codes. Arc flash and shock hazard appropriate PPE is required. This equipment must be adequately grounded in accordance with local electrical codes or, in the absence of local codes, with the current edition of the National Electrical Code NFPA No. 70.

**Working on Energized Circuits**

When electrical repair or maintenance work is required that prohibits de-energizing the circuits involved, extreme caution must be used. The work should be completed only by authorized, well trained and supervised personnel who are fully aware of the dangers involved. All practical safety measure must be used to protect the personnel performing the required work. In addition to the NFPA No. 70 codes, the following precautions **must** be taken:

1. Remove all wristwatches, watch chains, rings, necklaces, metal appendages to clothing, oversized metallic belt-buckles, metal piercings, or loose clothing. These items have the potential to make accidental contact with energized surfaces. In addition, secure long hair with a hair net or cover with a plastic helmet.
2. Remove all hair barrettes or bobby pins. These items are electrically conductive and accidental contact may cause serious personal injury.
3. Wear dry clothing and shoes. Moisture should not be present on the soles of shoes. Water is electrically conductive and accidental contact may cause death or serious personal injury.
4. Insulate the worker from the ground. Cover any adjacent grounded metal surfaces with an insulating material. Suitable insulating materials are dry wood, rubber mats, dry canvas, dry phenolic material, or heavy, multi-ply paper (cardboard). Make sure that the insulating material has no holes present and there are no conductive materials (e.g., staples) embedded. Cover a sufficient area with the insulating material to make sure that adequate space is permitted for worker movement.
5. Use insulated tools when working on energized circuits or fuse box. These insulated tools must be rated to withstand the voltage of the energized circuits.

**Notes for the Installation Electrician**

The installation electrician must take the following precautions:

1. Locate and review the electrical schematics furnished with the equipment.
2. Verify the proper fit-up, wiring and operation of all required electrical components.
3. Mount the push button station out of reach of someone located on the carriage (approximately 6' [1,829 m]).
4. Wire standard lift limit switches on the chain tensioning assembly (see the job specific electrical schematic as required) for mechanical VRCs as follows:  
If the tensioner chain becomes slack causing the arm on the limit switch to move down or if a strong tension is exerted on the tensioner chain causing the arm to move up, there is a break in the control power. The limit switches are designated with an LS# on the electrical schematic.



## Safety First

The most common reason to access the area below a raised carriage deck is to clean debris from the pit or hoistway. This is best accomplished using a long handled broom or rake to avoid entry under the raised carriage deck. Entry under the raised carriage deck is acceptable only when unavoidable and then only if the proper precautions are taken. It is the user's responsibility to ensure that the following conditions be met before allowing qualified personnel to enter the area under the raised carriage deck.

- Work must be performed by qualified maintenance technicians.
  - ◇ A qualified person is defined as a person who, by possession of recognized degree or certificate of professional standing or by extensive knowledge, training, and experience, has successfully demonstrated his/her ability to solve problems relating to the subject matter and work.
- The facility has performed a Risk Assessment per ASME B20.1 5.16
  - ◇ Reference OSHA 3071 for Job Hazard Analysis
  - ◇ Reference CEMA Technical Report 2015-01, ASSE Z590.3, and MIL-STD-882 for Risk Assessment examples.
- A proper lockout/tagout (LOTO) procedure has been performed on the VRC.
  - ◇ Refer to ANSI/ASSE Z244.1-2003 (R2014), Control of Hazardous Energy — Lockout/Tagout and Alternative Methods, and OSHA Standard 29 CFR 1910.147, The Control of Hazardous Energy (Lockout/Tagout).
- At least two (2) means of support are used to secure the raised platform.
  - ◇ The lifting systems can be used as one means of support provided that no work is to be done on the hydraulic system or mechanical drive system and an appropriate LOTO has been performed on the VRC.
  - ◇ Additional means of support include adequately sized maintenance chains, maintenance pins, DeckLocks, or straps with shackles around the drivebase that are capable of supporting the weight of the carriage.

## Minimize the Hazards

Every employee must be aware of the hazards before entering the area under a raised carriage. Take appropriate steps to minimize these hazards and any others that are identified. Some of the more common hazards are:

- Inadequate refuge space
- Confined space
- Improper air quality
- Inadequate lighting
- Improper access
- Tripping hazards
- Unsafe or lack of pit ladders
- The presence of moisture/water/oil
- Moving equipment

## General Guidelines

- Where a VRC is operating in a multiple unit hoistway, that portion of the hoistway where the work is to be performed shall be fully separated or accessible equipment locked out.
- Ensure that all portable lights and tools are connected through a Ground Fault Circuit Interrupter (GFCI).
- Provide adequate lighting especially if in a shaftway.
- For a deep pit, never "jump" into the pit – always use a ladder.
- Use proper hand protection while cleaning the area beneath a raised carriage.
- Remove parts, lubricants, cleaning equipment, etc. from inside the pit.
- Do not stand on the hydraulic piping or electrical conduit.
- Never straddle over the traveling cable(s) if so equipped and protect it against damage.

# Entrance Below a Raised Carriage Deck



MATERIAL HANDLING SOLUTIONS

www.pflow.com  
P 414 352 9000  
F 414 352 9002  
6720 N. Teutonia Ave.  
Milwaukee, WI 53209

---

## Pit Access

Access to the area beneath the raised carriage deck can be gained through manual measures implemented by qualified maintenance technicians.

---

## Manual Access

1. Call the carriage to the lower level.
  2. Open the lower gate and bypass the gate open switch at the interlock or in the main control panel. If there is any confusion about how to do this, call PFlow Industries, Inc. Customer Support Department.
  3. Barricade the lower level gate opening to prevent unintended access and provide hazard warning signs.
  4. Verify that the carriage is empty. Raise the carriage to the upper level making sure all personnel are clear of the moving carriage.
  5. Lockout the VRC in accordance with the facility lockout/tagout program.
  6. Secure the carriage at the upper level using adequately sized maintenance chains, maintenance pins, or straps with shackles around the drivebase that are capable of supporting the weight of the carriage to provide additional safety.
- 

## NOTICE

Do not attempt to do any work on the lifting system (e.g., hydraulic system, motor drive). When work is to be done on the hydraulic system or mechanical drive system, a different procedure must be followed. The carriage must be landed on stands or secured by another means in order to prevent any weight from relying on the lifting means or when the hydraulic pressure is fully relieved. Consult PFlow Industries, Inc.

---

7. Return to the lower level and verify that the gate and the carriage does not move if the push-buttons are pressed. Wedge or block the lower level gate in the open position to prevent the gate from closing while someone is in the pit area.
  8. Perform the necessary maintenance, adjustments, or cleaning under the carriage.
  9. Exit the pit and remove the wedge or block holding the lower level gate open.
  10. Reverse the process to return the VRC into service.
-



## Unique Descriptions and Names

PFlow Industries, Inc. has incorporated, as well as created, a number of unique descriptions, names, and terminology for parts, components, and devices included in the Vertical Reciprocating Conveyor (VRC). This glossary includes these unique terms and other common terms to help understand this manual and the information it contains. In addition, the glossary will aid the user in communicating the correct information during troubleshooting and service situations. Although the wording and descriptions may sound familiar to the person who has read the manual, other terms and descriptions might not. It is recommended by PFlow Industries, Inc. that this glossary be reviewed before reading the remainder of this manual.

<b>Alkyd paint</b>	A fast-drying enamel paint, color-mixed per the customer's request, and applied using standard methods as specified by the paint manufacturer.
<b>ANSI</b>	American National Standards Institute: <a href="http://www.ansi.org">www.ansi.org</a>
<b>ASME</b>	American Society of Mechanical Engineers: <a href="http://www.asme.org">www.asme.org</a>
<b>Authorized person</b>	Trained or qualified personnel approved to perform a specific duty or duties.
<b>Back-frame</b>	The vertical portions of the carriage on a cantilever VRC, typically a series D vertical support mast.
<b>Backstop panel</b>	Also known as a Mezzanine roll-off panel, this is a panel that is installed opposite the loading edge at upper loading levels of a VRC platform that does not penetrate a floor. The backstop panel helps protect personnel and/or products from falling off the platform when loading or unloading. This term should not be confused with the term "backstop" as defined in ASME B20.1.
<b>Backstop</b>	As defined by ASME B20.1; A mechanical device to prevent reversal of a loaded conveyor under action of gravity when forward travel is interrupted.
<b>BVAC</b>	A bi-panel vertical acting gate.
<b>Cantilever</b>	A style of VRC where the carriage rides along the guide columns that are located on the same side of the carriage. This style lift can accommodate loading on three sides; right, front, and left.
<b>Capacity</b>	The maximum load for which the VRC is designed.
<b>Carriage</b>	The entire structural assembly that travels on the guide columns and carries the load.
<b>Carriage gate</b>	A gate that is mounted directly on the carriage deck.
<b>CEMA</b>	Conveyor Equipment Manufacturers Association: <a href="http://www.cemanet.org">www.cemanet.org</a>
<b>Chain</b>	See Drive chain, Lift chain and Roller chain.



---

<b>Chain Driven Live Roller (CDLR)</b>	A horizontal conveyor that is driven by separate loops of chain or a continuous chain. The chain contacts all roller sprockets, depending on the type and function of the horizontal conveyor. Either double or single sprockets are fitted to the horizontal conveyor rollers.
<b>Chain Guide Tube</b>	A tube welded to the back side of the VRC column that encloses the lift chain and tensioner chain.
<b>Chain tensioner</b>	A device that monitors the lift chain tension. If the lift chain is too tight, becomes slack, or breaks, the limit switch mounted on the chain tensioner will trip and remove control power.
<b>Columns</b>	The vertical structural members in which the wheelblocks attached to the carriage travel up and/or down.
<b>Column splice</b>	Columns shipped in more than one piece must be joined in the field during installation. Field assembly and welding is required.
<b>Constant Pressure Push Button</b>	A push button which must remain pressed and maintained by the operator in order to perform a desired operation. If the push button is released, the desired operation will stop.
<b>Controls</b>	Any combination of electrical devices used to control the operation of a VRC. This normally includes push buttons, relays, limit switches, interlocks, etc.
<b>Control Panel</b>	An enclosure housing various electrical components that control the VRC.
<b>Control voltage</b>	The control voltage is typically provided by the control transformer and is used to energize the various low voltage electrical devices.
<b>Conveyor, Vertical Reciprocating</b>	See Vertical Reciprocating Conveyor (VRC).
<b>Dead load</b>	A static load that is a permanent force, acting on a structure (see Platform).
<b>Deck</b>	The floor of the carriage (can be smooth plate, tread plate, or open).
<b>DeckLock System</b>	An added measure of safety to prevent uncontrolled descent of the carriage.
<b>Diagonal drop bar</b>	Load-defining bar and snap chain across operating end(s) of the carriage to define the load area on the platform which may minimize load movement. The diagonal drop bar is hinged at the base and swings down. This is not a load stop.
<b>Direct acting cylinder</b>	The cylinder which transmits lifting force directly to the carriage rather than through the use of cables, pulley, or chains.
<b>Drivebase assembly</b>	Gear reducer, brake motor and mechanical components that power the chain that lifts and lowers the carriage for mechanical VRCs. This assembly is typically mounted at the top of the lift guide columns.

---



---

<b>Drive chain</b>	Drive chains on the F series mechanical VRC, through a series of a shaft and sprockets allow the carriage to be raised and lowered.
<b>Drift</b>	The action of a lift carriage slowly dropping, usually due to slight internal leaks in a hydraulic system or mechanical slippage of a motor brake.
<b>EBVAC</b>	An electrically powered bi-panel vertical acting gate.
<b>Effective width/length</b>	Refers to usable space for the materials load on the carriage, not the overall dimensions which includes space allowed for carriage side guards and snap chains.
<b>Electrical cable</b>	Electrical cables consist of at least two conductors contained within a protective outer cover.
<b>Enclosure (lift guarding)</b>	Structure surrounding a VRC to prevent outside interference with its normal operation and to safeguard personnel. Typically 8' (2438mm) high panels composed of expanded metal or other materials that will prevent a 2" (51mm) diameter ball from passing through (ASME B20.1 requirement).
<b>Epoxy coating</b>	Abrasion-resistant, two-part industrial-strength protective coating system applied over sandblasted and primed steel or direct to metal. The epoxy coating is ideal for outdoor, chemical, or caustic wash-down environments or applications where standard alkyd enamel is viewed as insufficient.
<b>EVAC</b>	An electrically powered single panel vertical acting gate.
<b>Expanded metal (EM)</b>	A sheet of metal uniformly slit and stretched, forming diamond-shaped openings in the metal sheet. Expanded metal is a one piece construction that will not unravel under normal circumstances and will hold its shape. Expanded metal comes in a standard (raised) or flattened diamond pattern in a variety of gauges, opening sizes, materials and sheet sizes.
<b>Explosion proof (EXP)</b>	Electrical devices (e.g., control panels, motors, limit switches) that are designed to operate safely in a specific location or area where potentially explosive environments can or do exist.
<b>Floor-to-Floor distance</b>	The distance from one operating floor level to the adjacent operating floor level (see Vertical travel).
<b>Full Height Enclosures (FHE)</b>	Structure surrounding the full height of a VRC to prevent outside interference with its normal operation and to safeguard personnel. Typically panels composed of expanded metal or other materials that will prevent a 2" (51mm) diameter ball from passing through (ASME B20.1 requirement).
<b>Gate</b>	A device that opens and closes manually or automatically to allow access to the carriage for loading and unloading. The gate is normally a swing, sliding, or vertical acting device constructed of similar expanded metal as the enclosure (see specific gate type).

---



<b>General Arrangement (GA) drawing</b>	The drawing produced by PFlow Industries, Inc. which shows the VRC lift, gates, and enclosures. The drawing may show but does not specify building details.
<b>Guarded by location</b>	Describes moving parts so protected by the parts remoteness from the floor, platform, walkway, or other working level, or by the parts location with reference to the frame, foundation, or structure to reduce the foreseeable risk of accidental contact by persons or objects. The parts remoteness from foreseeable, regular, or frequent presence of public or employed personnel may constitute guarding by location in reasonable circumstances. (See ASME B20.1 standard)
<b>Guide angles</b>	Guide angles are attached to the guide column to help capture and contain the guide wheels in the columns and guide the carriage.
<b>Guide column</b>	The structural members connected to the carriage that guide the carriage travel up and down.
<b>Header</b>	Header refers to the horizontal structure spanning the width of the carriage or gate. The carriage header defines the load height on straddle units.
<b>HMI (Human Machine Interface)</b>	The user interface in the control system that provides graphic control of the VRC. The HMI communicates with the programmable logic controller (PLC).
<b>Hollow shaft</b>	VRC mechanical shaft of the mechanical drivebase which penetrates the gear motor rather than coupling to the gear motor. This minimizes wear points.
<b>Hydraulic cylinder</b>	A device which converts fluid power into linear force and motion. The hydraulic cylinder usually consists of a movable element such as a piston and piston rod, plunger or ram, operating within a cylindrical bore.
<b>Hydraulic power unit</b>	Refers to motor, pump, and reservoir assembly. The reservoir is shipped with oil. Most hydraulic power units come with the control panel attached and pre-wired to the hydraulic pump.
<b>Incoming voltage</b>	The main voltage being supplied for operation of the equipment.
<b>Interlock (Gate/Door)</b>	An electro-mechanical locking system used on the gates or access doors of a VRC. The system prevents the VRC operation unless all such gates or access doors are closed. The system also prevents the opening of any such gate or access door unless the VRC carriage is present at that particular landing or opening.
<b>Intermediate level</b>	A floor level or levels between the uppermost and bottommost operating floor.
<b>Junction box</b>	An electrical control box used to join, centralize, and distribute wiring from different locations.
<b>Keylock control</b>	A keyed push button station that prevents unauthorized use of the VRC.
<b>Kick plate</b>	A curb on the outermost edge of the inoperable sides of the carriage deck which is designed to contain product and is a minimum of 4" (102mm) high.
<b>Knock-down (KD)</b>	Lift components shipped in two or more pieces. Typically field welding is required (e.g., KD carriage, KD headers, KD uprights, KD gates, etc.).





---

<b>Landing</b>	A permanent-working surface at a fixed elevation used for loading or unloading the carriage.
<b>Lift chain</b>	A chain that lifts the carriage and load.
<b>Lift location light</b>	Illuminated push button that indicates at which level the carriage is located.
<b>Lifted load</b>	The total weight that the VRC is designed to lift at a specific speed. Typically, this is the dead load plus live load (see Rated load).
<b>Limit switch</b>	An electrical device which is used to control the carriage position and monitor various mechanical devices.
<b>Load pattern</b>	<p>A method to describe the direction a load can be moved on and off a carriage at different operating floors or levels. These can be used in combinations.</p> <ul style="list-style-type: none"> <li>● <b>“C” load pattern:</b> Carriage configuration allowing a load/unload opening on one side of the carriage deck.</li> <li>● <b>“Z” load pattern:</b> Carriage configuration allowing a load/unload opening on opposite sides of carriage deck.</li> <li>● <b>“90 degree” load pattern:</b> Carriage configuration allowing a load/unload openings at right angles on the carriage deck.</li> </ul>
<b>Load test</b>	The carriage is loaded to rated capacity, and the lift is operated.
<b>Macropoxy</b>	Macropoxy is a fast drying, polyamide epoxy designed to protect steel in industrial exposures. Ideal for protection of sharp edges, corners, and welds.
<b>Mechanical stop</b>	A mechanical means of stopping travel at a fixed position.
<b>Momentary contact push button</b>	A push button which only has to be pressed for an instant to activate the desired operation.
<b>Non-operating end</b>	The side(s) of a carriage not used for loading/unloading. Handrails or expanded metal sides and kick plate are normally supplied as minimum guarding.
<b>Operating end</b>	The side(s) of the carriage used for loading/unloading. At a minimum the side(s) are normally equipped with a safety chain as guarding.
<b>Overall dimension</b>	The outside dimension of the carriage structure or the entire lift.
<b>Overtravel limit switch</b>	A safety device provided on mechanical VRCs to stop carriage travel beyond the uppermost or lowermost floor level if the floor level positioning limit switch fails.
<b>Photo eye</b>	Photoelectric sensor that uses a focused beam of light to span the distance to a reflector. The VRC controls receive a signal when the reflected beam of light is detected by a sensor.
<b>Pit</b>	A depression in the floor a minimum of 1" (25mm) deeper than the carriage profile, which allows the carriage deck to be flush at operating floor or level.
<b>Platform</b>	The structure that forms the floor of the carriage and that directly supports the load (see Deck).
<b>Pneumatic gate operator</b>	A device that requires in-plant, clean and dry air to automatically open and close a gate. The device can be operated by either manually through the use of pull cords or push buttons, or automatically through the use of a PLC.

---



---

<b>Pressure switch (hydraulic)</b>	A sensor which detects hydraulic pressure. The sensor can be set to trip at a predetermined pressure. When this pressure setting is reached, the pressure switch will activate, opening the control circuit and stopping the pump motor.
<b>Programmable Logic Controller (PLC)</b>	A micro-processor based device that controls the VRC or Cartveyor™ through a resident software program.
<b>Push-button (PB) station</b>	The wall mounted, pedestal mounted, or hand held device used to control the operation of the VRC.
<b>Qualified person</b>	A person, who by possession of a recognized degree, certificate, professional standing, or skill, and who by knowledge, training and experience, has demonstrated the ability to deal with problems relating to the subject matter, the work, or the project.
<b>Ramp</b>	An access ramp used to load on and off of a carriage deck.
<b>Rated load</b>	The load the VRC is designed for and installed to lift at a rated speed (see Lifted load).
<b>Reflector</b>	A plastic, prismatic object used to reflect a beam of light emitted from a photoelectric sensor.
<b>Roll-off panel</b>	See Back-stop panel.
<b>Roller chain</b>	The type of chain drive most commonly used for transmission of mechanical power. The roller chain consists of a series of short cylindrical rollers held together by side links and connecting pins. The roller chain is driven by a toothed wheel called a sprocket.
<b>Safety cam</b>	Spring-loaded, hardened steel cam directly attached to the lift chain or gate chain that engages if the lift chain or gate chain breaks or slackens, preventing the carriage or gate panel from dropping more than a few inches.
<b>Side guards</b>	A protective enclosure on the outermost edge of the inoperable sides of the deck welded to the carriage to contain load. Can be rails, sheet steel, or expanded metal.
<b>Slack chain device</b>	A device that monitors a chain and trips if the chain goes slack. If the chain becomes slack or breaks, the limit switch mounted on the slack chain device will trip and remove power to the circuit.

---



---

<b>Spliced guide column</b>	Guide column that is fabricated and delivered in two or more sections necessitated by manufacturing, handling, or installation constraints.
<b>Sprocket</b>	A wheel typically mounted on a shaft. The wheel has a row of teeth around its edge that fit into the links of a chain.
<b>Straddle</b>	A style of VRC where the carriage rides between two guide columns that are located on opposite sides of the carriage. This style of lift will accommodate “C” and “Z” type loading patterns.
<b>Top of roller (TOR)</b>	Top elevation of a horizontal conveyor system roller which is also the lower elevation of the load.
<b>Touchscreen</b>	See HMI.
<b>Transom</b>	A panel or panels used to close an enclosure opening above the VRC entrance.
<b>Travel</b>	The difference in elevation between the bottommost level of the carriage platform and the uppermost level of the carriage platform, regardless of whether the carriage is pit or floor mounted.
<b>UHMW (Ultra-High Molecular Weight)</b>	An abrasion-resistant, high-impact, polyethylene material used throughout the VRC to protect and/or guide moving parts.
<b>Uprights</b>	The portion of the carriage that houses the wheels that guide the carriage between the columns.
<b>VAC</b>	A single panel vertical acting gate.
<b>VFD (Variable-Frequency Drive)</b>	A VFD is a type of drive used in electro-mechanical drive systems to control AC motor speed and torque by varying the motor frequency and voltage.
<b>Velocity fuse</b>	A device that senses hydraulic flow across a control orifice when the pressure differential exceeds a predetermined amount. A spring-biased poppet closes, shutting flow to the damaged hydraulic circuit and prevents the lift carriage from descending.
<b>Vertical travel</b>	Distance the carriage deck travels; floor-to-floor or total distance (see Travel).
<b>Vertical Reciprocating Conveyor (VRC)</b>	A reciprocating power actuated lifting device (not designed to carry passengers or an operator) that receives loads on a carriage and transports these objects from one operating elevation to another.
<b>VRC specification sheet</b>	PFlow Industries, Inc. informational data sheet providing general information on a specific VRC.
<b>Wheelblock assembly</b>	Sub-assembly fastened to the carriage upright that contains the guide roller elements and safety cam for the chain driven VRC lift. The lift chain is typically attached to the wheelblock assembly safety cam.

---



---

**Gate Types:**

**Single swing gate**

This type of gate hinges on one side and latches on the other, may be either right or left-hand swing. Clear space is required in front of the VRC for the gate to swing open.

---

**Bi-parting swing gate**

The bi-parting, swing gate has hinges on each side and latches in the center. Clear space is required in front of the VRC for the gates to swing open.

---

**Single panel vertical acting gate (VAC)**

The VAC gate panel closes to the floor and opens in the upward direction.

---

**Double panel vertical acting gate (BVAC)**

The BVAC gate is the same as the single panel VAC above in operation and use except the two (2) panels telescope from a nested position.

---

**Horizontal sliding gate**

The horizontal sliding gate operates in the same manner as a vertical acting gate except the gate functions in the horizontal direction.

---

**Roll-up door**

The roll-up door can be anything from an industrial type roll-up steel door to self-storage facility type door.

---

**F Series**

Drive chain sprocket

Drive chain tensioner assembly

Drivebase assembly

Strut channel

Drive chain

Lift chain

Drive support strut

Column

Column-to-Column  
brace

Carriage

Carriage upright

Twin roller guides

Deck, Platform

Chain tensioner

Landing

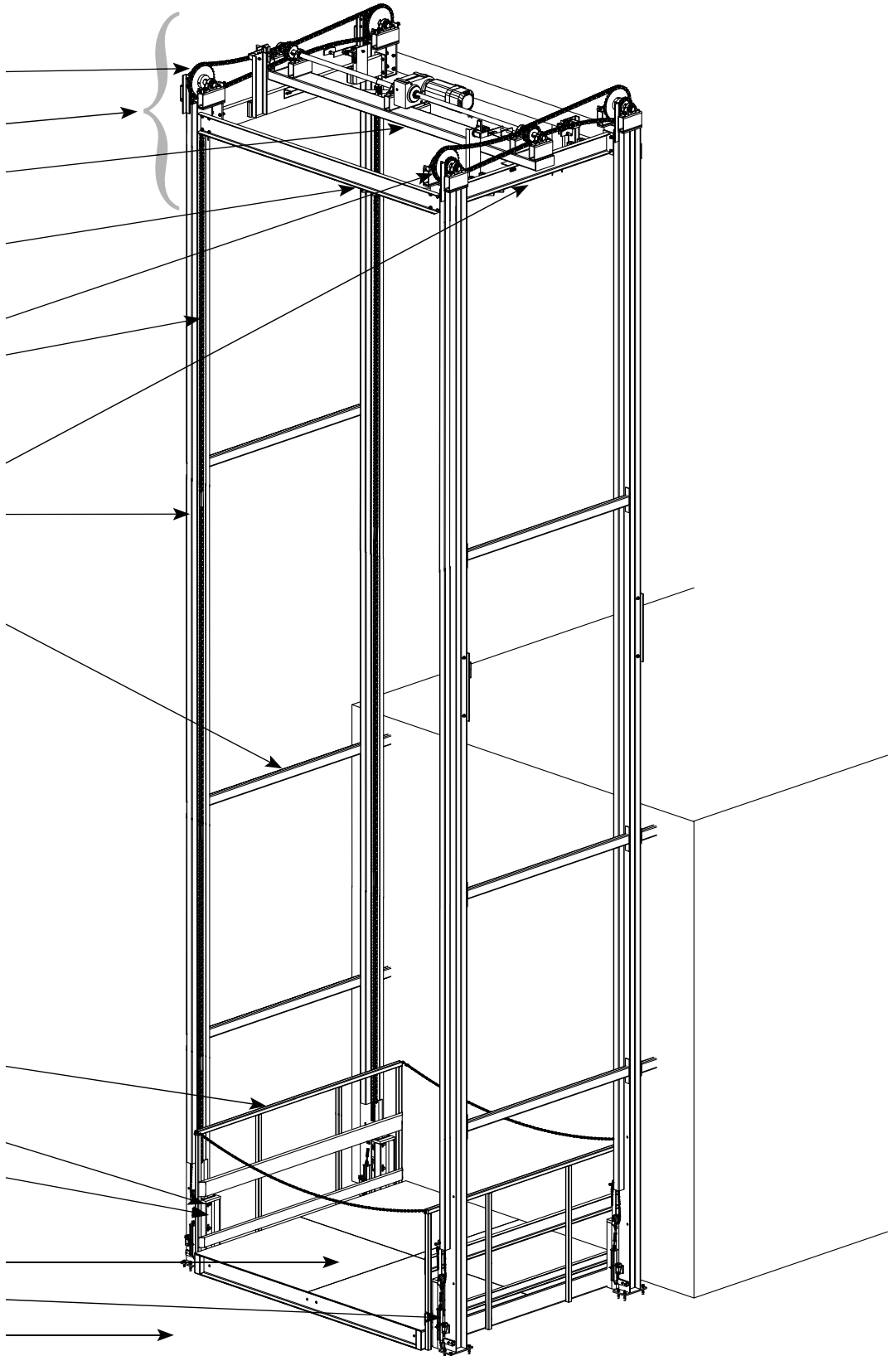

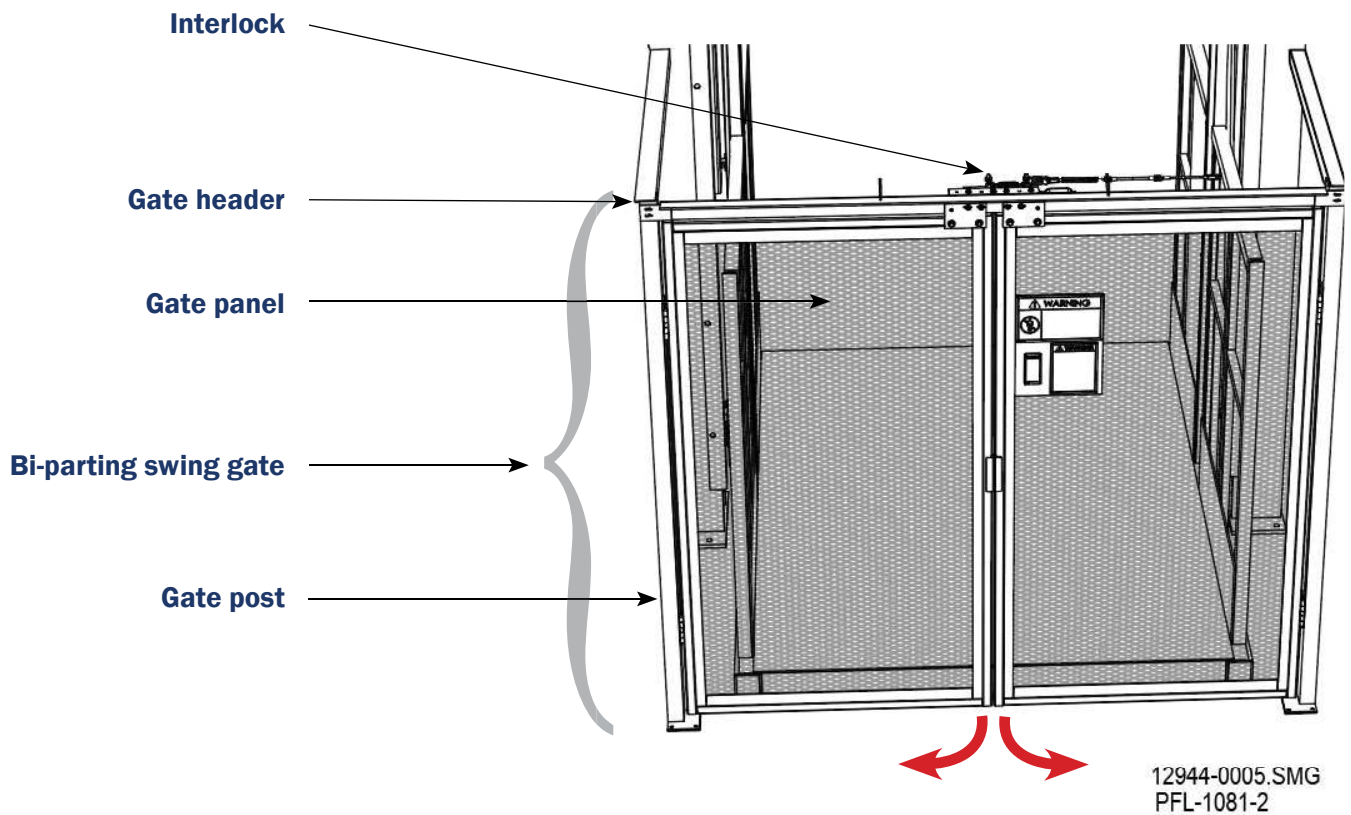
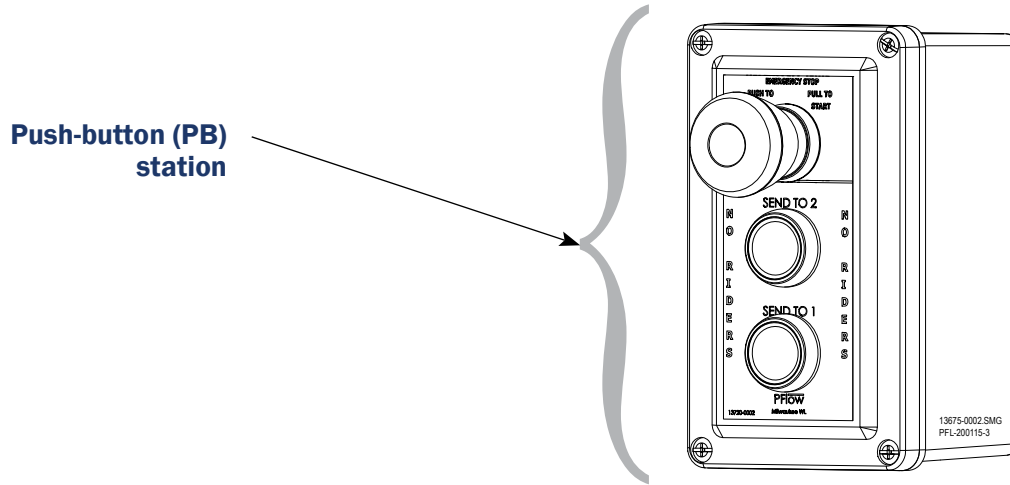



**Field Electrical Wiring Standards**

All electrical wiring and craftsmanship completed in the field shall be in accordance with existing state, local and National Electrical Code (NEC) standards.

**Definitions**

**In-field electrical wiring**

All hard wiring of all electrical devices external of control panel.

**Control circuit**

The control circuit refers to all circuits and devices at 120 VAC and below.

**Power circuit**

Power circuit refers to all circuits and devices at 208 VAC and above.

**Systems**

Systems refers to automated vertical and horizontal conveyors.

**Requirements**

1. It is recommended that all control circuit wiring is #14 AWG, copper, stranded, type THHN or equal, 600 VAC.
2. It is required that all power circuit wiring is #12 AWG minimum (sized appropriately for the load), copper, stranded, type THHN or equal. A green grounding wire shall be provided to power devices.
3. Per NFPA 79, the colors of individual conductors shall be:
 

Power wiring - Black	24 VAC neutral - White
115 VAC - Red	24 VDC - Blue
115 VAC neutral - White	0VDC - White/blue
24 VAC - Red/black	Ground - Green or green/yellow

**Note:** These colors only apply to individual conductors. These colors do not apply to prefabricated cables.

4. All wires must be labeled on each end with the wire number from the electrical drawing using a machine or computer generated label, utilizing black characters on a white background.
5. All field devices must be individually terminated in the control panel.
6. Screw on solderless connectors (wire nuts) shall be of the insulated type, spring lock, and of the proper size to accommodate wires.
7. Terminal lugs shall be of the insulated type, crimp style, and of the proper size to accommodate wire(s) and terminal fasteners.
8. Conduit and related hardware shall conform to local, state, and NEC standards. The minimum size shall be 1/2". Connectors and couplings shall be appropriate for conduit type.
9. Flexible conduit shall be a minimum of 1/2", shall be of the liquid-tight type, and shall be installed with compatible liquid-tight connectors.
10. The customer shall locate and install a fused disconnect switch within the line of sight of the control panel. The customer shall ensure accessibility to the disconnect switch with regard to existing electrical codes and standards.
11. Control wiring and conduit shall be separate from the power wiring and conduit.
12. When mounting resistor banks, make sure the resistor elements are horizontally positioned.
13. Drop cords (flexible cords) shall be multi-conductor festoon-type cable where applicable.

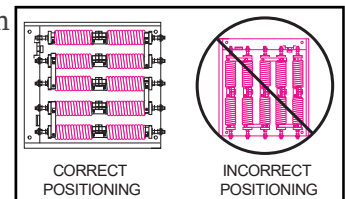

*Resistor Bank Positioning*



**Electrical Ruling Bodies**

- 
- NEMA** ***National Electrical Manufacturers Association*** provides national testing and manufacturing standards body of electrical apparatus.
- 
- UL** ***Underwriters Laboratories, Inc.*** is an independent testing laboratory. Many local codes require UL control panels and electrical apparatus.
- 
- JIC** ***Joint Industry Council*** is an advisory group that provides standards for production equipment, safety, and dependability.
- 
- NFPA** ***National Fire Protection Association*** is the ruling board of NEC and sets national fire and safety standards for equipment and manufacturing facilities.
- 
- CSA** ***Canadian Standards Association*** is a regulatory agency of Canada.
- 
- ANSI** ***American National Standards Institute*** oversees the creation, promulgation, and use of thousands of norms and guidelines that directly impact businesses.
- 
- ASME** ***American Society of Mechanical Engineers*** is a leader in technical innovation with a focus on advancing and applying engineering knowledge and communicating the excitement of engineering. This group is the Secretariat for ANSI.
- 
- NEC** ***National Electrical Code*** is an advisory board to NFPA with recommendations and codes usually adopted throughout the United States.
- 

**PFlow's Standard**

NEMA 12 classification is to be used in a general purpose, indoor only application.

All PFlow Industries, Inc. control systems are built to a NEMA 12 minimum classification. All PFlow Industries, Inc. control systems conform to the following standards:

- **NFPA 70 (NEC):** The National Electrical Code.
  - **NFPA 79:** Electrical standard for industrial machinery.
- 

**Outdoor Application**

Outdoor equipment or electrical devices exposed to severe weather conditions should not be rated less than NEMA type 4. This is a watertight, dust-tight, indoor-outdoor classification that will provide protection against splashing water, seepage of water, falling or hose-directed water, and severe external condensation.

---

**Corrosive Application**

The chemical industry on the whole usually specifies a minimum NEMA type 4X. A NEMA 4X rating is similar to a NEMA 4 with added corrosion resistance.

---





---

**PFlow's Standard  
(continued)**

**Hazardous Location**

Hazardous locations are an extremely specialized electrical classification. Few electrical experts exist in this field. All hazardous locations must be handled as defined by the class, division, and group designator for the job site condition.

The NEC has three classes (I, II, III), - two divisions, (1 and 2) and seven group designations (A, B, C, D, E, F, and G).

---

**Class Definitions**

**Class I locations:** Locations in which flammable gases, flammable liquid-produced vapors, or combustible liquid-produced vapors are or may be present in the air in quantities sufficient to produce explosive or ignitable mixtures.

**Class II locations:** Locations that are hazardous because of the presence of combustible dust.

**Class III locations:** Locations that are hazardous because of the presence of easily ignitable fibers or where materials producing combustible flyings are handled, manufactured, or used, but in which such fibers/flyings are not likely to be in suspension in the air in quantities sufficient to produce ignitable mixture.

---

**Division Definitions**

**Division 1** is an extremely dangerous explosive condition that exists normally.

**Division 2** is a dangerous explosive condition that could exist but usually does not.

---

**Group Designations**

Group designations are given by the NFPA, State Fire Marshals, insurance companies or consulting engineering firms according to the gasses, dust, or other particles in the area and the spark or temperature needed to produce an explosion.

---

## Section 6 | Electrical Standards and Definitions



**MATERIAL HANDLING SOLUTIONS**

[www.pflow.com](http://www.pflow.com)  
P 414 352 9000  
F 414 352 9002  
6720 N. Teutonia Ave.  
Milwaukee, WI 53209





**Mechanical Overview**

Each F series (mechanical) Vertical Reciprocating Conveyor (VRC) consists of four (4) columns, a drivebase assembly with a gearmotor reducer, drive shaft with four (4) corner lift sprocket assemblies, a moving carriage deck, and if furnished, interlocked safety gates or doors. See Figure 7-1. In addition, a main control panel, and one push-button station per level are furnished. For more information on the electrical components, see Section 8 in this manual.

**Lift Columns**

The frame consists of four (4) vertical upright columns. These are anchored to the floor at the lower floor level, positioned by the drivebase at the top, and braced to the building structure. Exact bracing varies by application.

Each column has a guide angle welded to one flange of the column to form a track. A chain tube guard is welded to the face of the other flange.

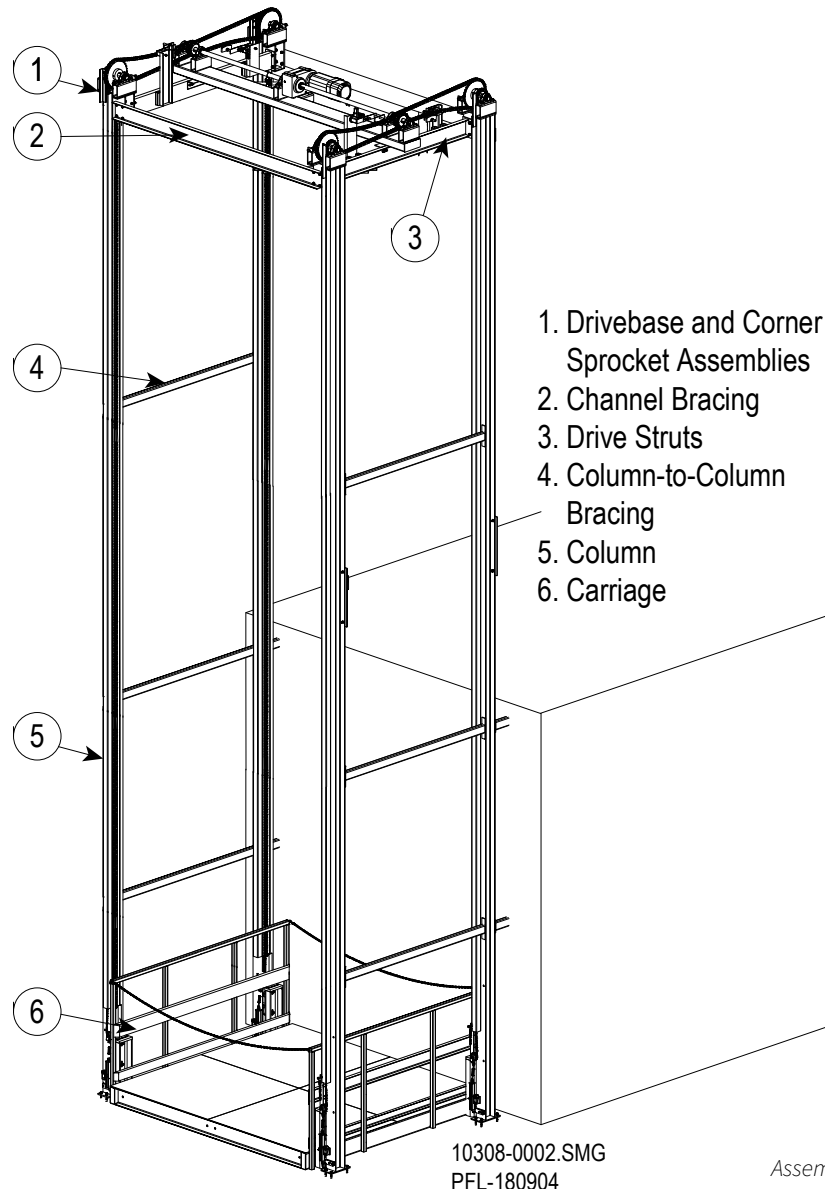

Assembled F Series  
Figure 7-1

**Drivebase Assembly**

The drivebase assembly consists of a motor, brake, gearmotor reducer (commonly referred to as a gear motor assembly), lift sprockets, a drive shaft, bearings, and a support structure. Roller chains connect the drive sprocket on the shaft of the drivebase assembly to the larger driven sprocket on the corner assemblies on top of each column. Roller lift chains connect to safety cams and tensioner chains and chain tensioners complete the components. See Figure 7-2, Figure 7-3, and Figure 7-4.

**NOTICE** This VRC uses special high strength chain. Do not use standard ANSI roller chain or connecting links as a replacement. Contact PFlow Industries, Inc. Customer Support Department for the required chain specification.

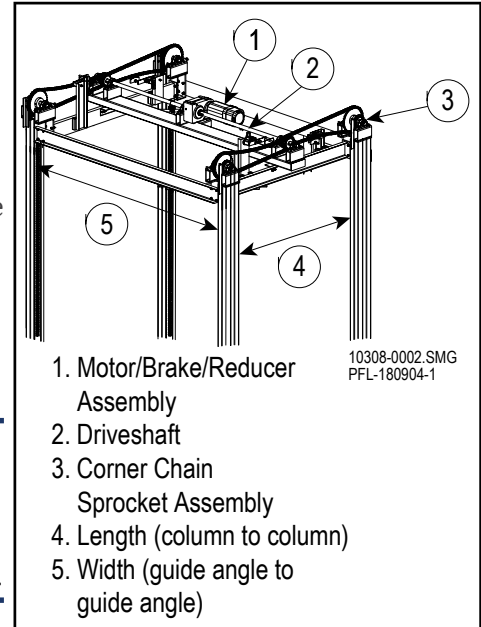

Drivebase Assembly  
 Figure 7-2

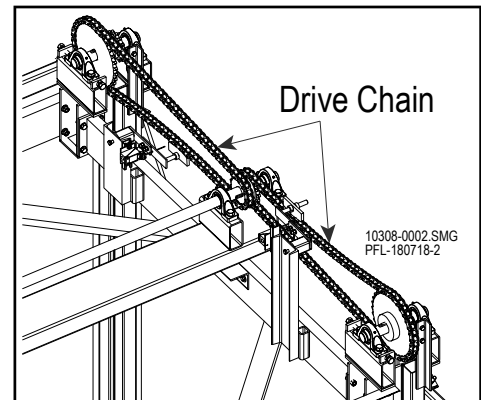

Drive Chain  
 Figure 7-3

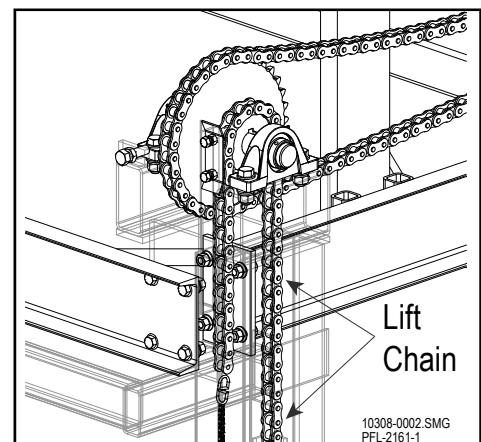

Lift Chain  
 Figure 7-4

**Safety Cam and Wheelblock**

Four (4) safety cam assemblies are bolted to the carriage uprights and reside inside the column. Two (2) twin roller guide wheelblock assemblies are bolted to the carriage (one on each front side) with one wheel riding within the column and the other wheel riding on the outside of the column. Two (2) special wheelblock assemblies are bolted to the carriage (one on each back side) with the block and one roller riding within the column and one roller riding on the outside of the column. This allows the wheels to ride along the lift columns and guide the carriage travel. See Figure 7-5.

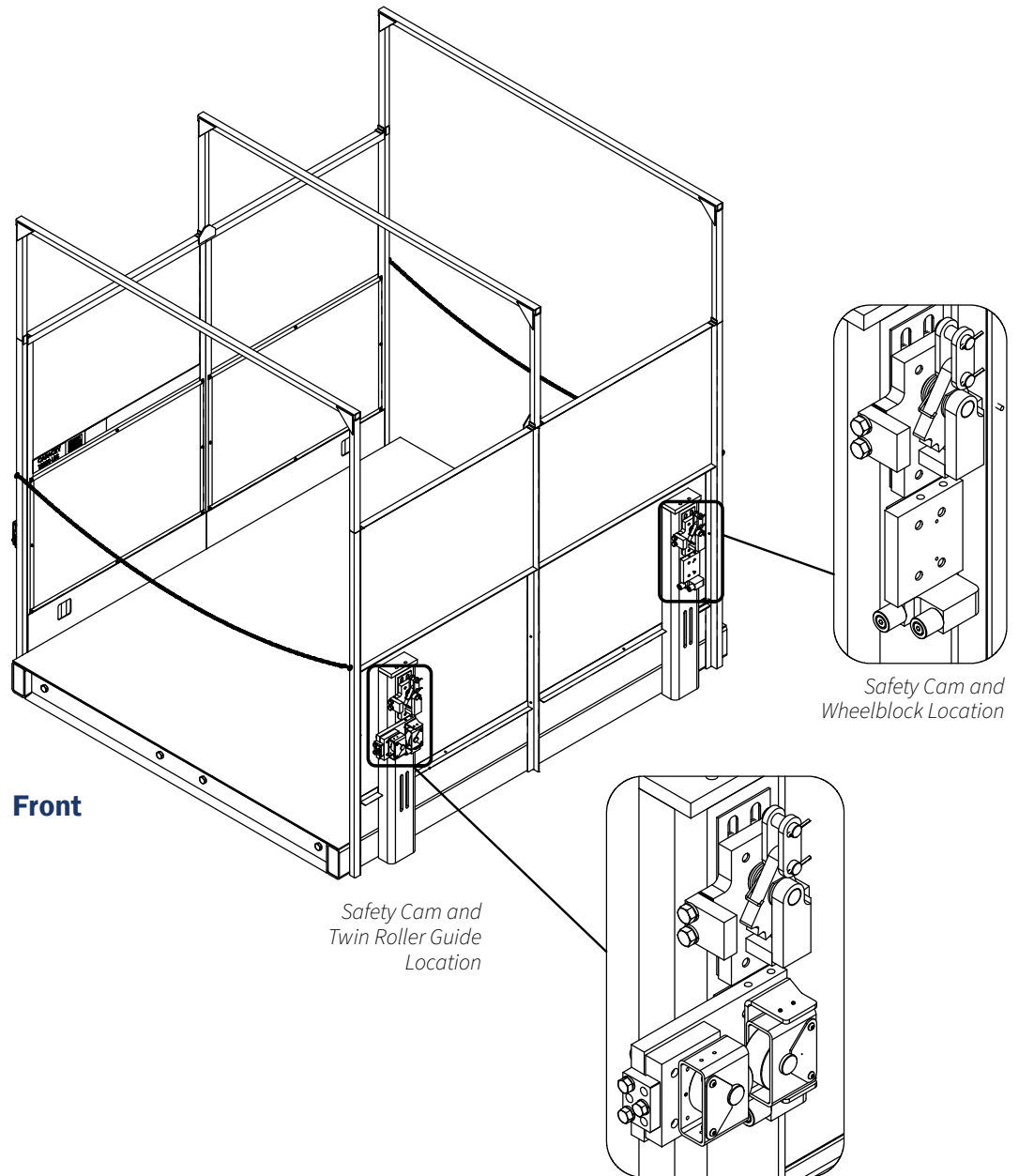

**Front**

*Safety Cam and Wheelblock Location*

*Safety Cam and Twin Roller Guide Location*

*Safety Cam and Rollers  
Figure 7-5*

**Lift Chains**

Inside each column, one end of the lift chain connects to a safety cam assembly which is bolted to the carriage upright.

The lift chain goes up and over the lift sprocket at the top of the column drivebase assembly, then proceeds downward through the chain guard (chain tube), and connects to the smaller tensioner chain.

The tensioner chain then travels around the small chain tensioner sprocket and back up to the carriage to fasten to a bolt on the standoff on the carriage upright.

The tensioner sprocket is spring-loaded by the chain tensioner which maintains tension on the chain/tensioner combination. If the lift chain is pulled too tight or becomes slack, the chain tensioner limit switch is activated to shut off power to the VRC.

The chain tensioner is adjusted at a turnbuckle on the chain tensioner assembly.

See Figure 7-6.

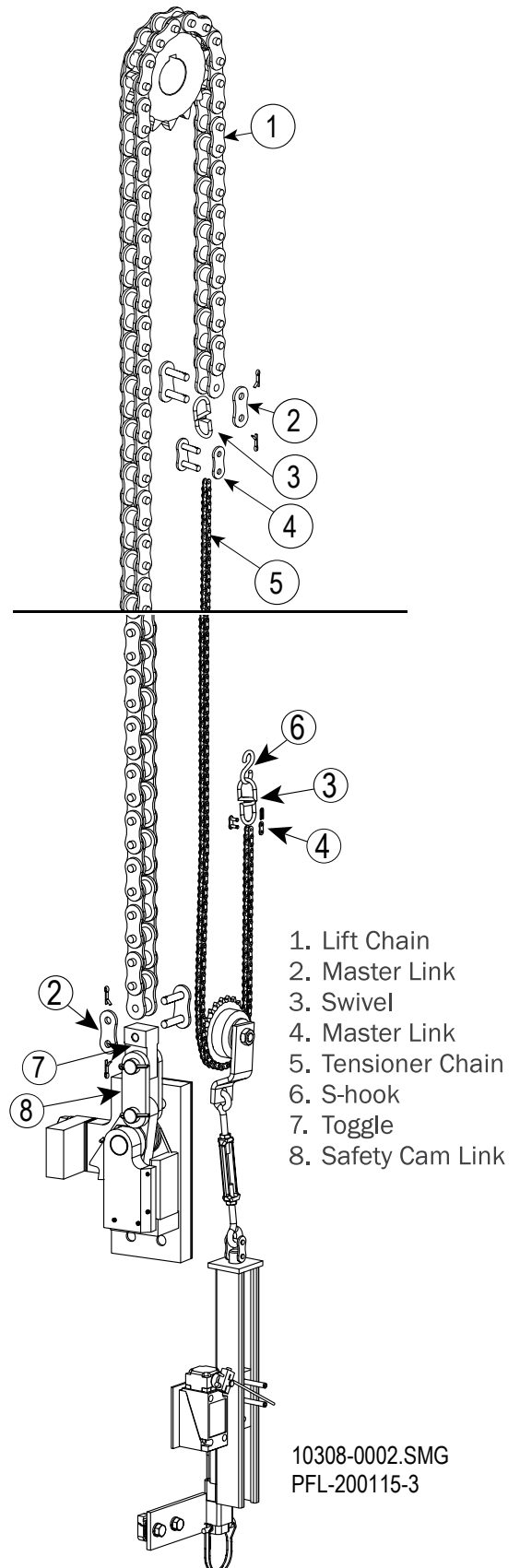

Lift Chain System  
 Figure 7-6

10308-0002.SMG  
 PFL-200115-3

**Safety Cam Function**

Each safety cam assembly has teeth and a shoe. The shoe (bolted to the safety cam assembly base) fits around the outside of the column guide angle track while the steel safety cam is pivoted on the safety cam mounting block. It is torsion spring-loaded. If the lift chain breaks or becomes slack, the safety cam pivots into a jam position with the column guide angle to stop the carriage from falling. The safety cam shoe on the outside of the guide angle track helps wedge the safety cam teeth. See Figure 7-7 and Figure 7-8.

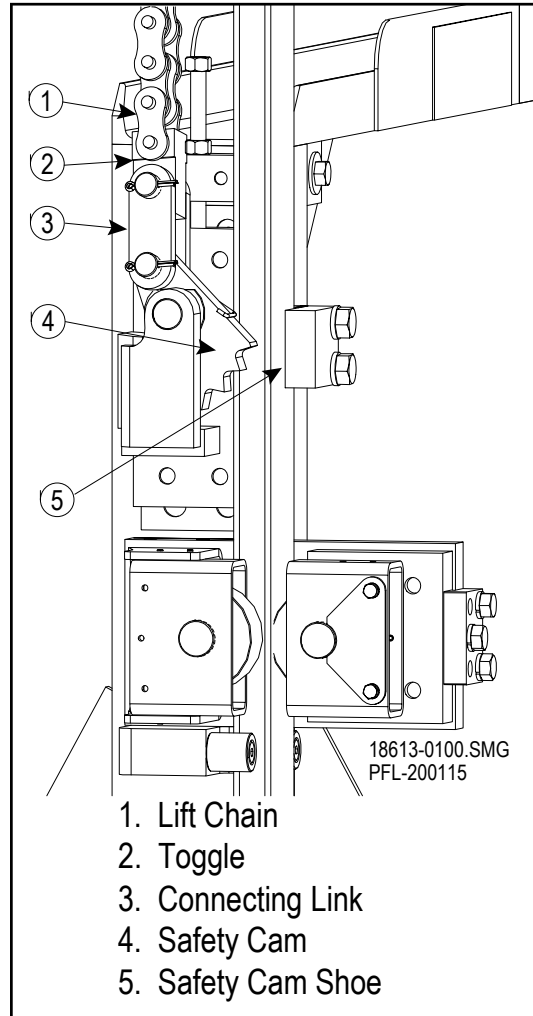

*Safety Cam Disengaged  
 Figure 7-7*

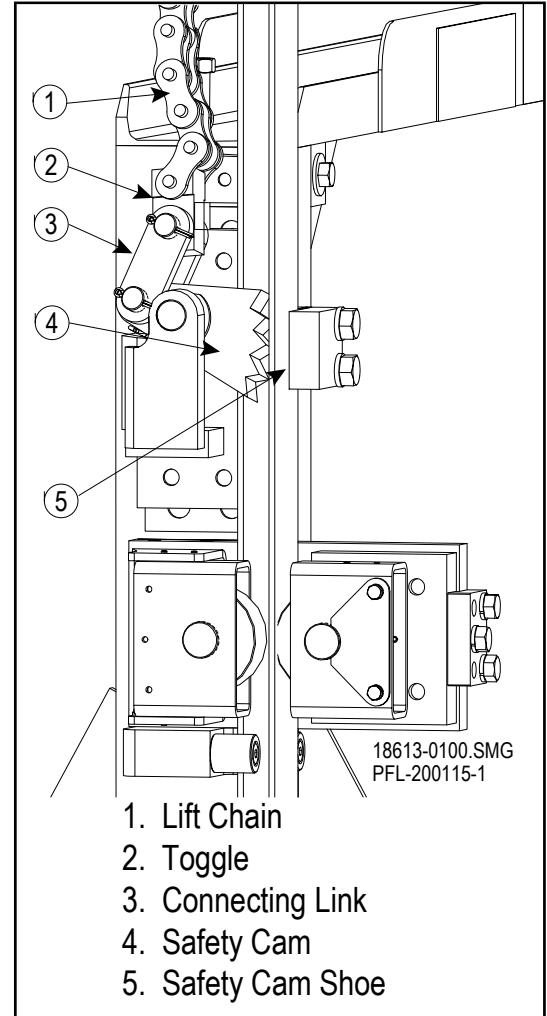

*Safety Cam Engaged  
 Figure 7-8*



**Enclosures**

In accordance with ASME B20.1, Section I-3.9, PFlow Industries, Inc. supplies standard 8' (2,438 m) tall enclosure panels to be installed around the Vertical Reciprocating Conveyor (VRC) as required by site conditions. The enclosure panels are steel with 1-1/2" (38mm) angle frame and 16 gauge flattened expanded metal designed to reject a ball 2" (51mm) in diameter. PFlow Industries, Inc. standard enclosure panels are typically 8' tall (2,438 m). Full height enclosures (FHE) are furnished when designed for site specific requirements. See Figure 7-9.

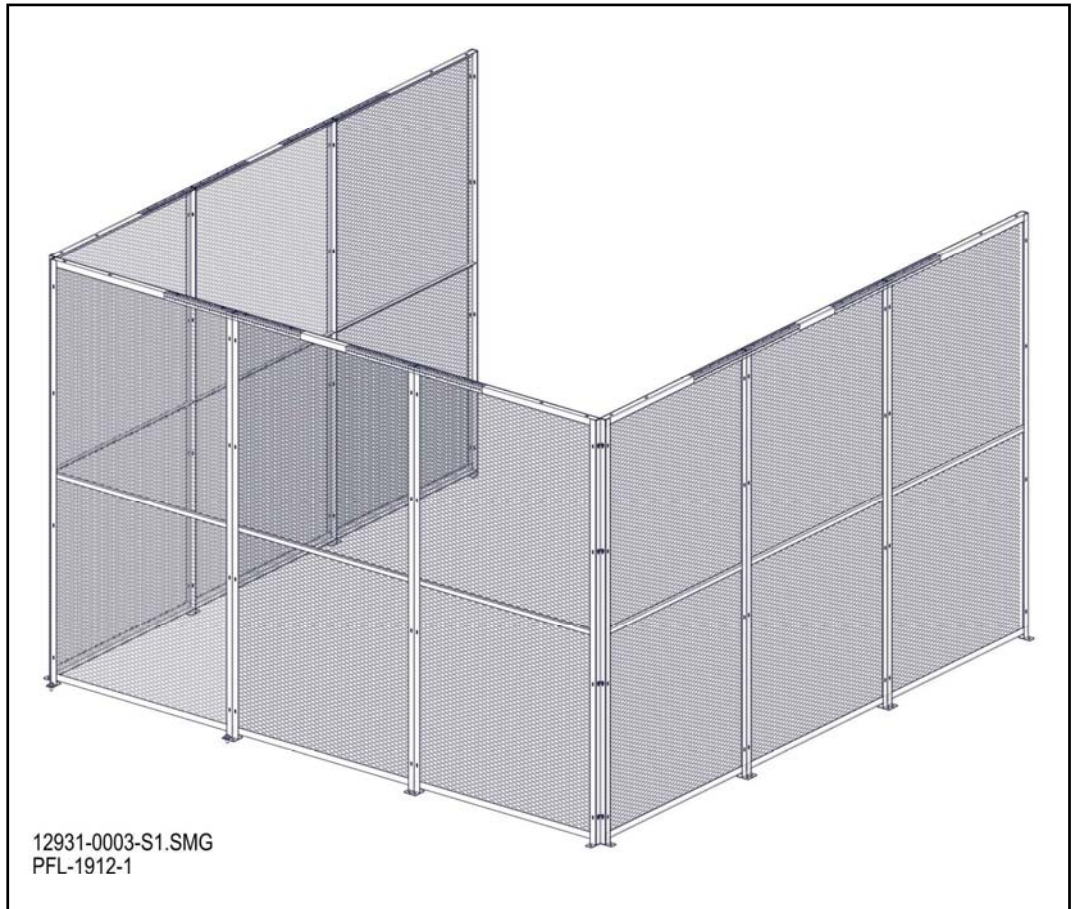

*Floor Level Enclosures  
Figure 7-9*



**Gate Assemblies**

A safety gate assembly or door is provided at each level opening accessing in the lift area. All gates and/or doors accessing the lift area are electromechanically interlocked. When a gate or door is open the interlock prevents movement of the carriage away from the respective level. When the carriage is not present at a level, opening the gate or door is prevented by the mechanical interlock. See Figure 7-10.

PFlow Industries, Inc. offers various styles of interlocks depending upon the gate type and application.

The parts section of this manual contains views with part numbers.

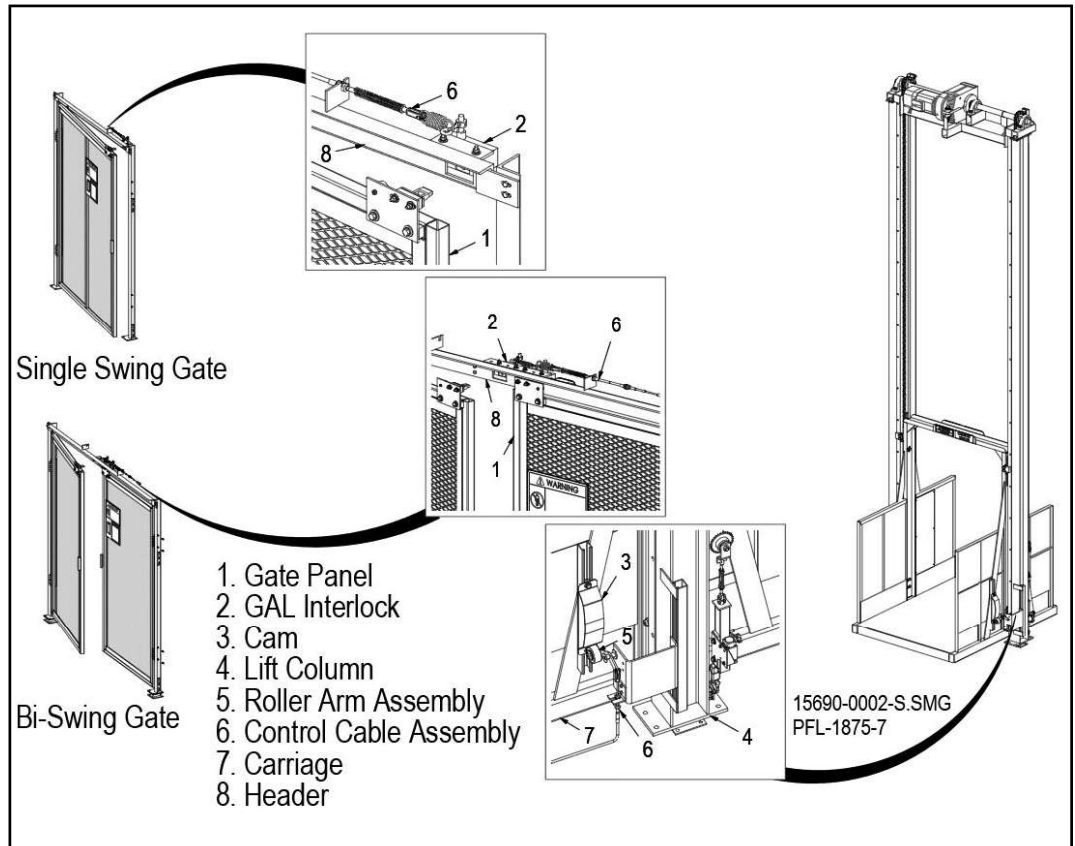

Swing Gate Interlock Examples  
 Figure 7-10

Examples

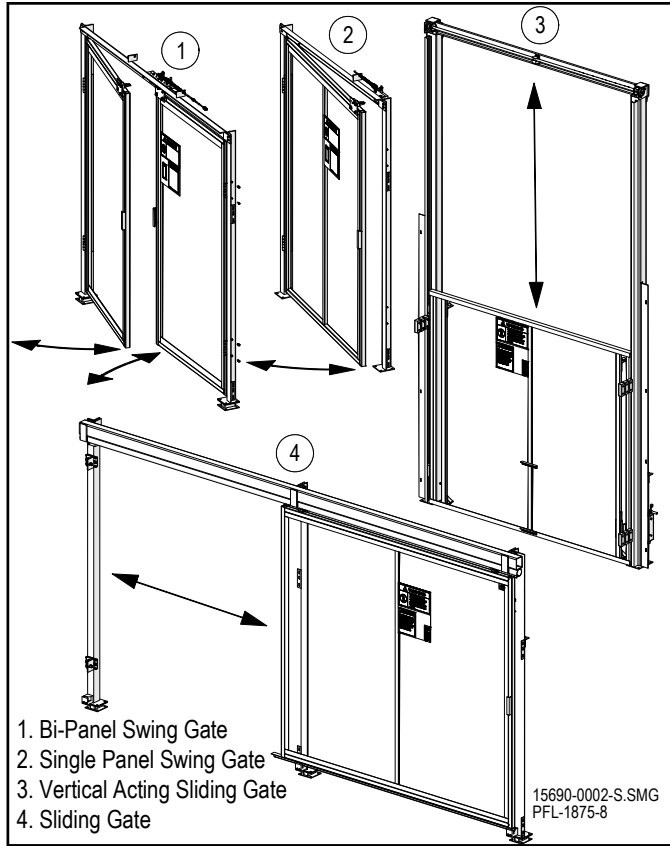

Swing Gate Interlock Examples  
 Figure 7-11

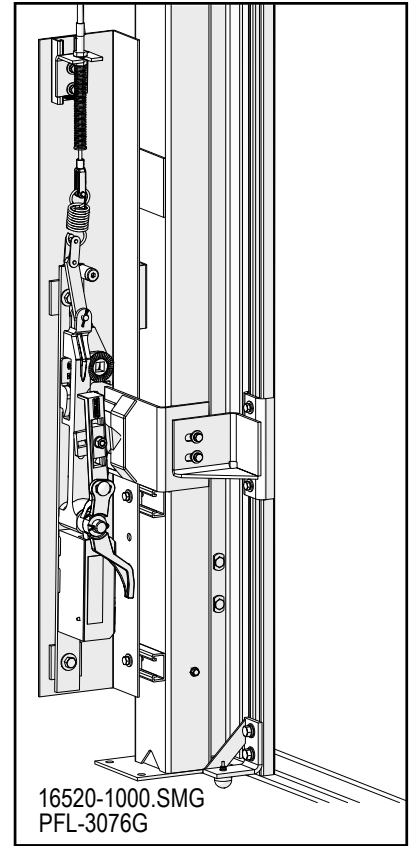

Peelle - VAC  
 Figure 7-12

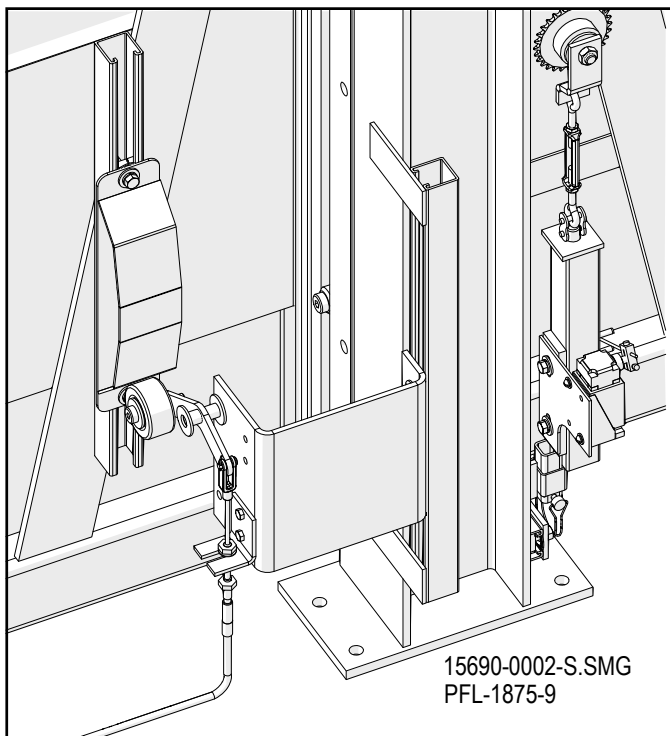

Cable Actuator  
 Figure 7-13

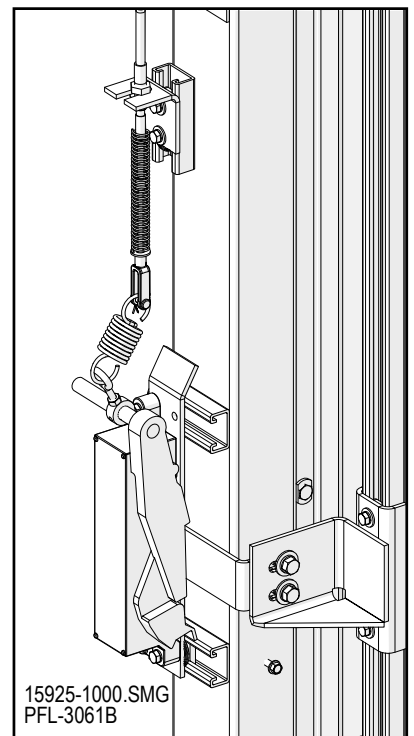

Anderson - VAC  
 Figure 7-14



**Electrical Overview**

The following is a standard description of the electrical wiring of an F series VRC. This does not include any specifics on options available or ordered (e.g., gates, DeckLocks, photo eyes). A copy of the electrical schematic can be found in the control panel and the shipping packet originally included in the parts crate.

**⚠ WARNING**

Falling hazard! Make sure all safety devices are in place and operable before using the equipment. If any safety device is missing or inoperable, immediately remove the equipment from service.

Per ASME B20, all gates or doors accessing the lift area must be electro-mechanically interlocked. This requires electrical contacts to prevent the lift from operating if a gate is open when the carriage is at the level and mechanical locks to lock the gate until the carriage is at that level.

**NOTE**

*Different gate interlock types and styles are supplied depending upon the gate type and site conditions. Standard gate styles incorporate one to four electrical components per gate.*

**Main Control Panel**

All electrical devices are connected individually to the main control panel. The main control panel contains a fused transformer, motor starter, relays, etc. A motor overload and current sensor is provided to protect the motor from excessive current draw.

**Push-Button Stations**

One (1) push-button station is normally supplied for each level. ASME B20.1 code requires that the push-button stations be remotely located and unable to be activated by someone standing on the carriage. Each push-button station contains Send to “x” push-buttons and an emergency stop (E-stop).

The Send to “x” push-buttons are momentary contact. This means the operator can press and release the Send to “x” push-button and the carriage will travel to the selected level. The operator does not need to hold the Send to “x” push-button for the carriage to continue moving. When pressed, the emergency stop prevents the carriage from moving. The emergency stop must be pulled out before carriage movement can be initiated again.

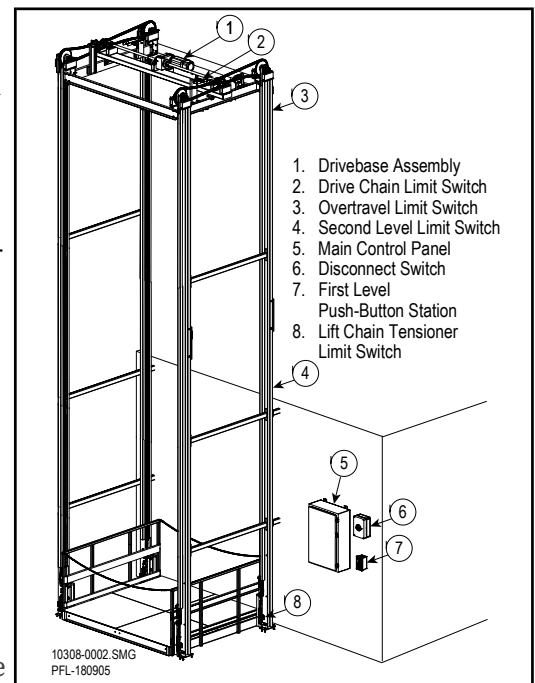

Electrical Components Figure 8-1

**Main Disconnect Switch**

As required by NEC code, the main disconnect switch must be lockable and located within line of sight of the control panel and no more than 6' 6" (1,981 m) off the floor.



---

**Drivebase  
Assembly**

The motor / brake is located on the drivebase assembly. The motor and brake wiring must be verified prior to energizing the VRC.

**Limit Switches**

The F series VRC has eight (8) limit switches incorporated into a standard two-level VRC: one (1) at each level to stop the carriage, one (1) overtravel, two (2) lift chain tensioner switches, and four (4) drive chain tensioner switches. All limit switches require field mounting and wiring. VRCs servicing more than two levels require two (2) additional limit switches for each intermediate level.

---



**Before You Begin**

**Read this entire manual before operating the Vertical Reciprocating Conveyor (VRC).**

Service must be performed by qualified and trained service technicians only.

**NOTICE**

A qualified person is defined as a person who, by possession of a recognized degree or certificate of professional standing, or by extensive knowledge, training, and experience, has successfully demonstrated his/her ability to solve problems relating to the subject matter and work.

Personnel to carry out work on the VRC must exclusively be qualified personnel who - based upon their education, experience, instructions as well as knowledge concerning relevant standards and provisions, accident prevention, regulations and operating conditions - have been authorized by the person being responsible for safety, to carry out the activities described in these instructions and who - when doing so - are in a position to recognize possible risks early and to avoid them.

**! DANGER**



- Stay within the rated lift capacity.
- Make sure all safety devices are in place and operable before using the equipment. If any safety device is missing or inoperable, immediately remove the equipment from service.
- Falling hazard! Always make sure the carriage is present before walking through doorways.
- Keep clear of unsupported platforms. Stay out of the area under a raised platform. If a maintenance operation requires the carriage to remain in the raised position, refer to Bulletin 15709-0083 for additional information or contact PFlow Industries, Inc. Customer Support Department for assistance.

**! WARNING**



- This equipment can be dangerous if not used properly. Allow only competent adults who have been properly trained and authorized personnel to operate this equipment.
- Passengers are not permitted. Riding may result in death or serious personal injury.
- Close all gates before the carriage is moved. Never leave the lift unattended with the gates in the open position. Never close gates when a person is on the carriage or within the fenced area.
- Avoid Shifting Loads! Place the load in the center of the carriage platform to avoid shifting loads. Lock rolling casters in place. Make sure that any portion of the load does not overhang the perimeter of the carriage. Prevent unstable load conditions.

**Begin Sequence**

1. Press the desired floor level button. See Figure 9-1. The coil in the motor starter magnetically closes the high voltage contacts and the power circuit to the motor starter. See Figure 9-2. This action turns the motor in the needed direction.
2. The brake is released. The motor turns the gears in the reducer, which in turn rotates the keyed drive shaft. The drive sprockets on the shaft turn resulting in the raising or lowering of the lift chains. The lift chains are fastened to safety cams, which are bolted to the carriage uprights. Adjustments to the safety cam levels the carriage deck.
3. When the carriage arrives at the next level, the floor level limit switch is activated by a carriage mounted cam. See Figure 9-3. When the floor limit switch is activated, the switch cuts the power to the motor circuit. The motor starter contacts open, the motor stops, and the brake is applied. This stops and holds the carriage position.

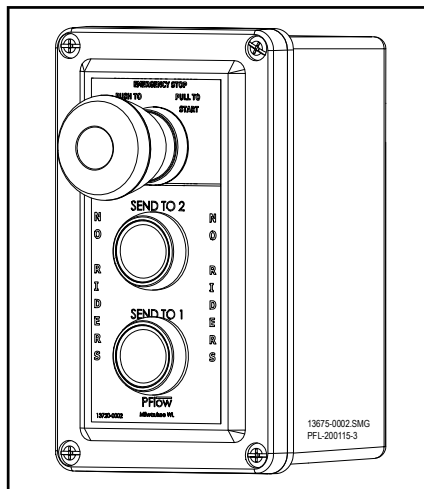

Push-Button Station  
 Figure 9-1

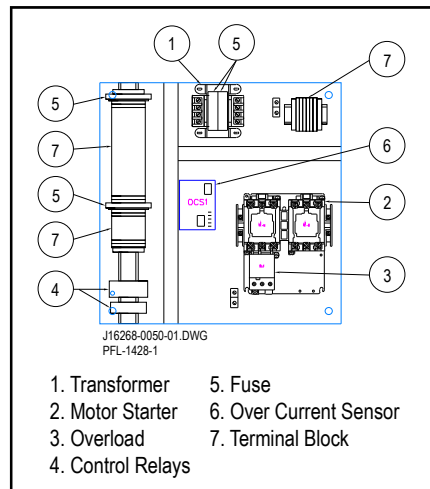

Control Panel Example  
 Figure 9-2

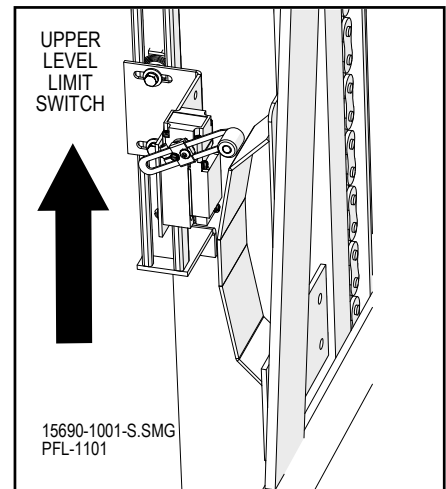

Limit Switch / Cam  
 Figure 9-3

**Sequence  
 (continued)**

- The carriage overtravel limit switch is a safety device mounted on the column above the uppermost floor level limit switch. In the event of failure to activate the uppermost floor level limit switch, the overtravel limit switch is activated when it comes into contact with the carriage mounted safety cam shoe on the side of the carriage. The switch cuts the power to the motor circuit. The motor starter contacts open, the motor stops, and the brake is applied. This stops and holds the carriage position. If the uppermost floor level limit switch fails, have a qualified electrical controls technician investigate why and correct the problem before re-activating the VRC. See Figure 9-4.

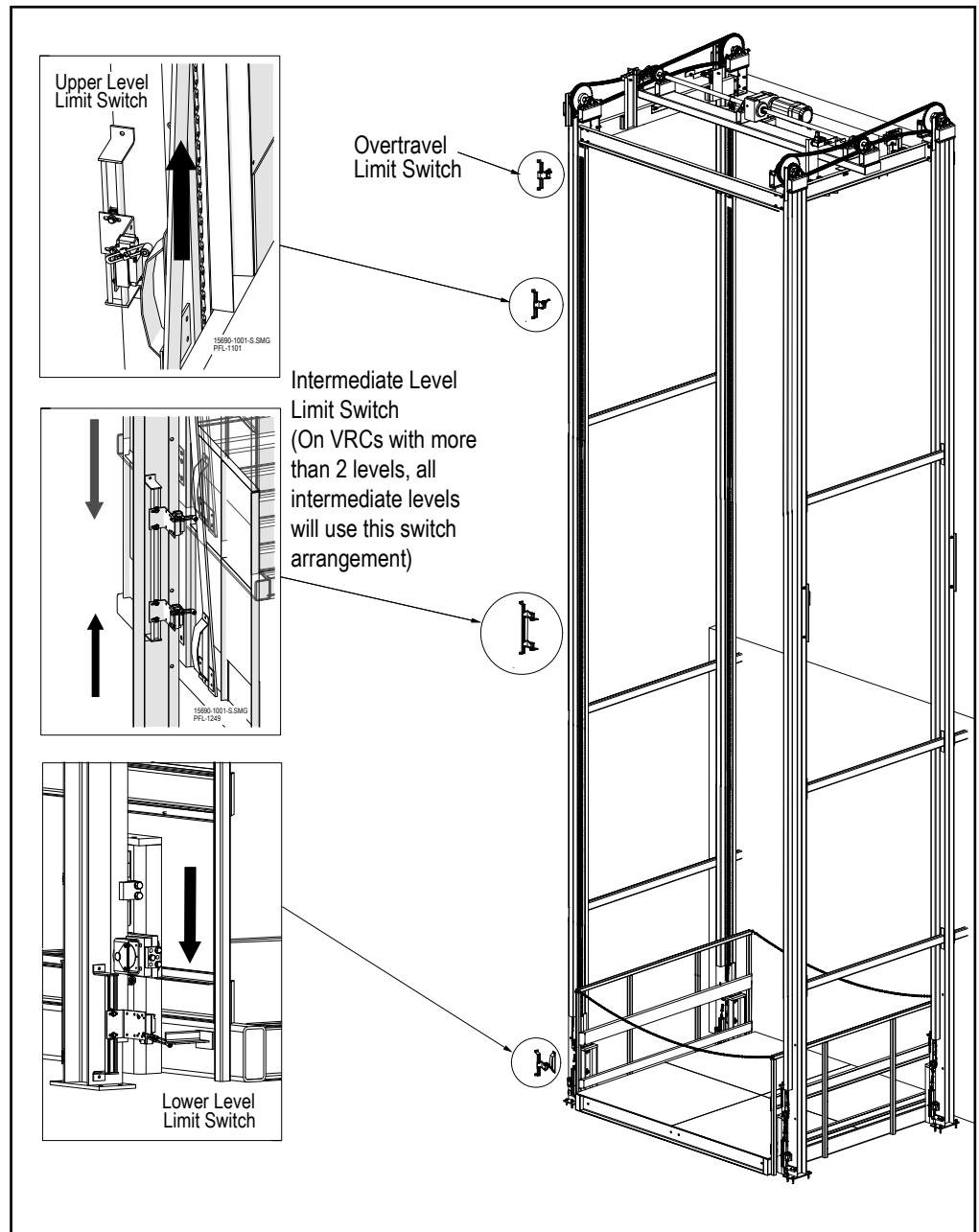

Limit Switch  
 Figure 9-4

**Sequence  
 (continued)**

5. If there is excessive motor current draw that causes motor overheating, the overcurrent sensor (OCS) in the control panel will protect the lift motor by cutting off the power to the control circuit. This will happen when the carriage is loaded beyond its rated capacity. See Section 15 for more information.
6. If either of the drive chains or lift chains break or becomes slack, the sensor limit switch activates to shut off power to the motor and apply the brake. The carriage stops. The VRC will not operate until the chain is repaired and the chain sensor readjusted. See Figure 9-5 and Figure 9-6.
7. The lift chain tensioner limit switch is typically mounted at the bottom of the lift column. If a lift chain becomes slack or broken, the chain tensioner limit switch activates to shut off power to the motor and apply the brake. The safety cam rotates and sets on the column. The carriage stops. The VRC will not operate until the lift chain is repaired and the chain tensioner readjusted. See Figure 9-6.

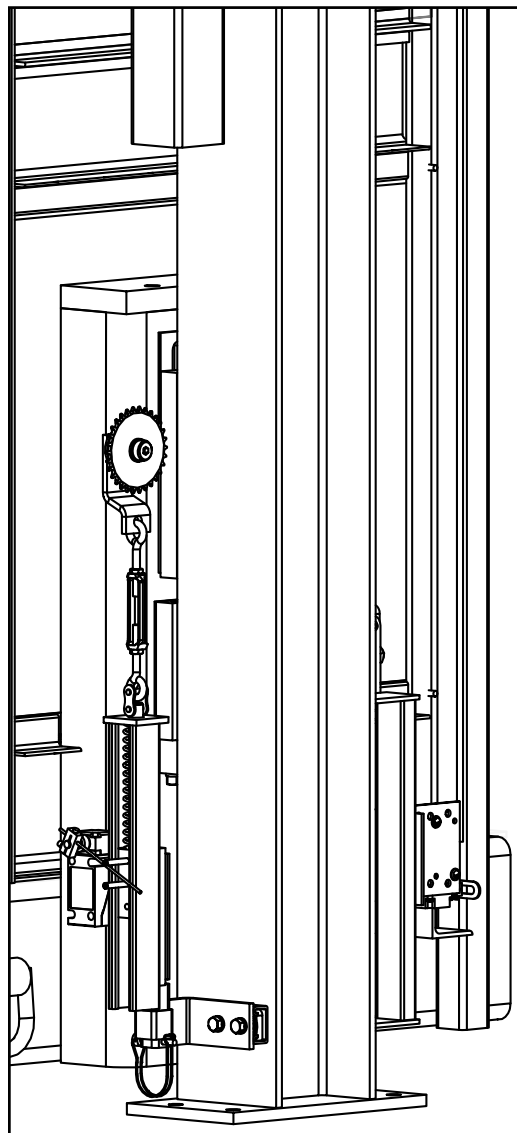

Lift Chain Tensioner  
 Figure 9-6

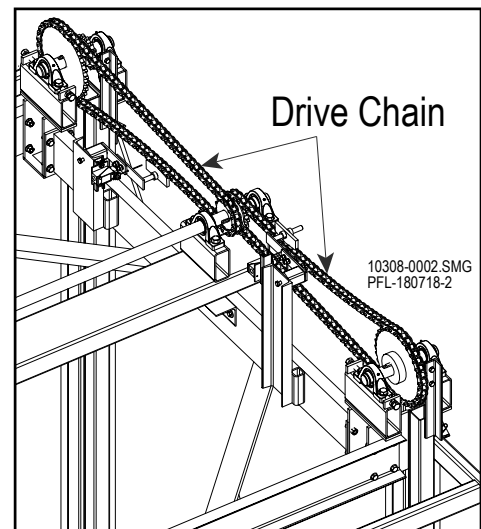

Drive Chain Tensioner Figure 9-5

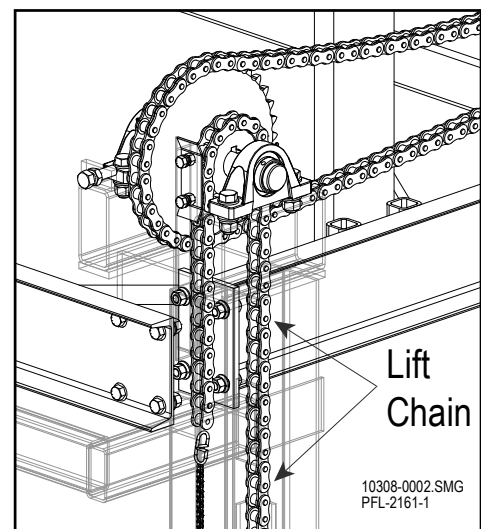

Lift Chain  
 Figure 9-7



### To Operate the Lift

1. Close all gates and make sure the gate latches are engaged.
2. Press the desired floor level button to move the carriage to the desired level. The carriage stops when the appropriate level is reached.
3. When the carriage arrives at the appropriate level and comes to a complete stop, open the gate.
4. If an emergency occurs while the carriage is moving, push the emergency stop (E-stop) button. The button will keep the VRC inoperable until the button is pulled out. See Figure 9-8.

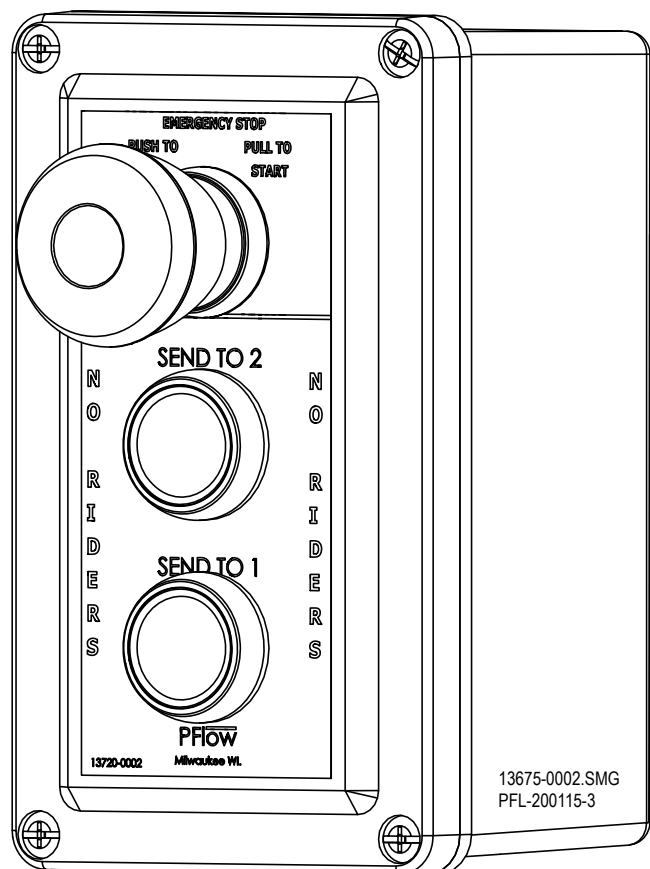

Push-Button Station  
Figure 9-8





**Before You Begin**

*Read this entire manual.*

This section is provided for the assistance of qualified and trained service technicians only and is not intended for use by untrained or unauthorized service personnel. This section is not a replacement for the SEW Eurodrive instructions. Additional resources and information can be found at [www.seweurodrive.com/support](http://www.seweurodrive.com/support) or confirm current information with SEW Eurodrive by calling 1-888-SEW-3876 and reference your serial number.

**NOTICE**

A qualified person is defined as a person who, by possession of a recognized degree or certificate of professional standing, or by extensive knowledge, training, and experience, has successfully demonstrated his/her ability to solve problems relating to the subject matter and work.

Personnel to carry out work on the motor or brake must exclusively be qualified personnel who - based upon their education, experience, instructions as well as knowledge concerning relevant standards and provisions, accident prevention, regulations and operating conditions - have been authorized by the person being responsible for safety, to carry out the activities described in these instructions and who - when doing so - are in a position to recognize possible risks early and to avoid them.

**Safety Information**



**⚠ DANGER**



High Voltage! Installation or maintenance work may only be performed when no power is available to the motor. Electric motors, electrical brakes, and variable frequency drives contain potentially dangerous high-voltage. Shut down the power at the circuit breaker or power switch. Employees servicing or maintaining VRCs may be exposed to death or serious personal injury if hazardous energy is not properly controlled. De-energize any circuit before work is begun. Do not touch live components or power connections immediately after disconnecting the device from the voltage supply because some capacitors may still be charged. Adhere to a minimum switch-off time of 10 minutes. Observe the corresponding labels on the device. Follow your facilities procedures or OSHA lockout/tagout (LOTO) procedures anytime maintenance or service is being performed on any electrical box or component.



Burn Hazard! Surfaces of motors and gear units may become hot during operation or shortly after start-up. In some instances additional protection against accidental contact may be necessary. Use caution to avoid burns or serious injury! Let the motor cool before work begins.

## Section 10 | SEW Eurodrive Motor Identification and Operation



MATERIAL HANDLING SOLUTIONS

www.pflow.com  
P 414 352 9000  
F 414 352 9002  
6720 N. Teutonia Ave.  
Milwaukee, WI 53209

### DRN Gearmotor Labeling

The SEW-Eurodrive model number consists of a series of letters to designate the type of unit or feature and numbers to designate the size and features of the unit.

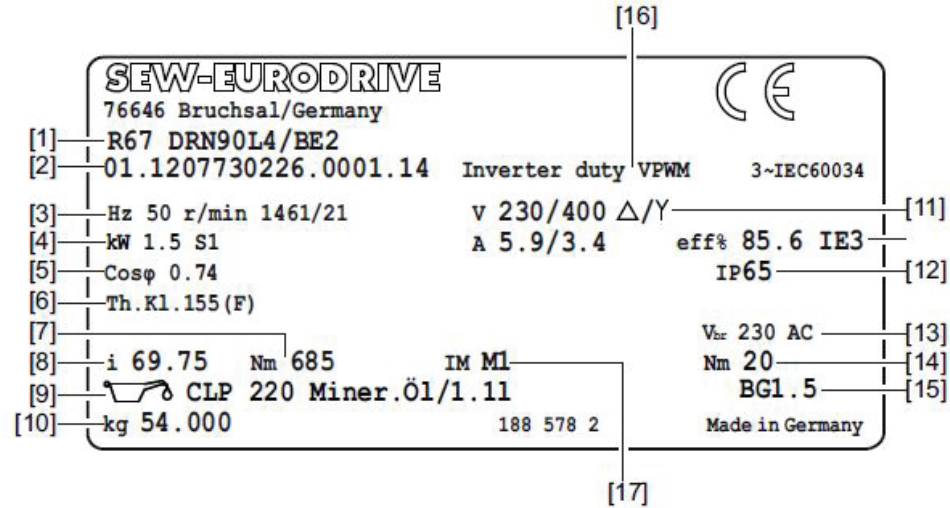

### Code Definitions

- |                                   |                            |
|-----------------------------------|----------------------------|
| [1] Type designation of gearmotor | [10] kb Weight             |
| [2] Serial number                 | [11] V Clamping connection |
| [3] Hz Line frequency             | [12] Degree of protection  |
| [4] kW Motor power                | [13] V Brake voltage       |
| [5] Power factor                  | [14] Nm Braking torque     |
| [6] Temperature class             | [15] Brake control         |
| [7] Nm Maximum output torque      | [16] Inverter operation    |
| [8] Gear unit ratio               | [17] Mounting position     |
| [9] Oil type and oil fill volume  |                            |

#### Explanation for serial number:

- 01 = Sales organization
- 012345678 = Order number (8 digits)
- 26 = Order item (2 digits)
- 0001 = Item number
- 14 = Year of manufacture

### NOTICE

Observe the data on all nameplates and verify published ratings for the item(s) in question. Do not operate any SEW Eurodrive equipment outside the published performance range. Failure to comply may result in damage to the drive unit, driven machine, or the environment.



**DRN Motor Labeling**

The SEW-Eurodrive model number consists of a series of letters to designate the type of unit or feature and numbers to designate the size and features of the unit.

[1] —	<b>SEW-EURODRIVE</b>						
	76646 Bruchsal / Germany						
[2] —	<b>DRN90L4/FF</b>						
[3] —	01.1808089014.0001.16						
[4] —	50 Hz	r/min 1461	v 220-230Δ/380-420Y	IP54	TEFC	3~IEC60034	
[5] —	kW 1.5	S1	A 6.0/3.45	P.F.0.74	Nom.Eff% 85.6	IE3	
[6] —	kW 1.5	S1	A 5.2/3.0	P.F.0.7	Nom.Eff% 86.5	IE3	
[7] —	60 Hz	r/min 1767	254-266Δ/440-460Y	K.V.A. -Code M			
	Th.Kl. 130 (B)	S.F.1.0	ML 02	Design NEMA A	CT 300-1800rpm		
	<b>FF FF165 D200 WE 24X50</b>						
	<b>IM B</b>						
[10] —	kg23.555	AMB C° -20...40	1885723	Made in Germany			

**Code Definitions**

- [1] Manufacturer, compliance markings
- [2] Type designation of motor
- [3] Serial number
- Number of phases and underlying rating and performance standards
- [4] Hz Rate frequency
- Rated speed
- Nominal voltage
- [5] kW Rated power, operating mode
- Rated current
- IE class
- [6] Power factor for AC motors
- Degree of protection according to IEC 60034-5
- [7] Temperature class
- Rated efficiency for motors included in the scope of IEC 60034-30-1
- [10] Weight
- Ambient temperature range
- Country of origin

**Explanation for serial number:**

- 01 = Sales organization
- 18080890 = Order number (8 digits)
- 14 - Order item (2 digits)
- 0001 = Quantity
- 16 = Year of manufacture

**NOTICE**

Observe the data on all nameplates and verify published ratings for the item(s) in question. Do not operate any SEW Eurodrive equipment outside the published performance range. Failure to comply may result in damage to the drive unit, driven machine, or the environment.

## Section 10 | SEW Eurodrive Motor Identification and Operation



MATERIAL HANDLING SOLUTIONS

www.pflow.com  
 P 414 352 9000  
 F 414 352 9002  
 6720 N. Teutonia Ave.  
 Milwaukee, WI 53209

### Motor Options and Nomenclature

PFlow Industries, Inc. offers many options for its motors. The option code will be shown in the motor nomenclature.

Lettering on the motor housing:

**DRN132M4/BE11/HR/FI**

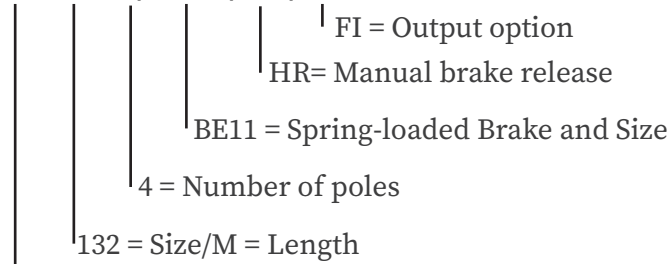

DR = Product Family/N = Product Line ID

### Motor Option Codes

DRN	Energy Efficient Motor, Premium Efficiency IE3	FI	IEC foot-mounted motor
BE	Spring-loaded Brake with specified size	F.A / F.B	Universal foot-mounted motor
HR	Manual brake release of the brake, re-engaging	FG	7-series integral motor, stand-alone
HF	Manual brake release, lockable	FF	IEC flange-mounted motor with bore
RS	Backstop	FT	IEC flange-mounted motor with threads
TF	Temperature sensor (PTC thermistor or PTC resistor)	FL	General flange-mounted motor (other than IEC)
TH	Thermostat (bimetallic switch)	FM	7-series integral motor with IEC feet
KY	KTY84 - 130 sensor	FE	IEC flange-mounted motor with bore and IEC feet
PT	1 or 3 PT100 sensor(s)	FY	IEC flange-mounted motor with threads and IEC feet
PK	PT1000 temperature sensor	FK	General flange-mounted motor (deviating from IEC) with feet
		FC	C-face flange-mounted motor, dimension in inches

**Activate Breather Valve**

1. Make sure the breather valve is activated before operating.
2. If not activated, pull the transport protection device up and away from the breather valve before starting the gearmotor.

**NOTICE**

Dirt and dust in the environment affect the function of the breather valve. Possible damage to unit. Inspect the breather valve function regularly and replace if necessary. In cases of high dirt and dust load use a breather filter instead of a breather valve.

Paint can block the breather valve and damage the sealing lips of the oil seals. Damage to unit. Protect the area by thoroughly covering the breather valve and sealing lip of the oil seals with strips prior to re-painting. Remove the protective strips after painting.

**Confirm the Oil Level**

1. Make sure the oil level corresponds to the mounting position before operating.
2. If the oil level is too low, open the oil fill plug and fill to the appropriate level with new oil of the same type through the oil fill plug. See Section 11 for additional details.
3. Tighten the oil fill plug.

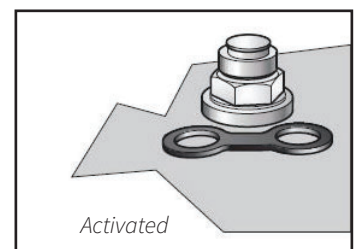
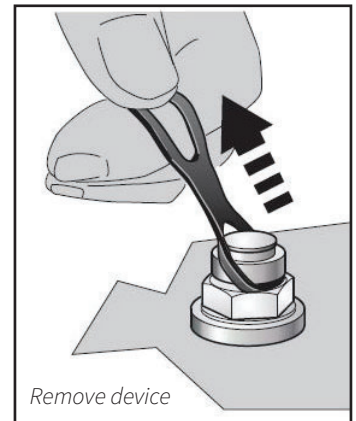
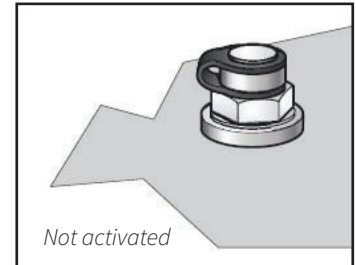

# Section 10 | SEW Eurodrive Motor Identification and Operation



**MATERIAL HANDLING SOLUTIONS**

[www.pflow.com](http://www.pflow.com)  
P 414 352 9000  
F 414 352 9002  
6720 N. Teutonia Ave.  
Milwaukee, WI 53209







## Before You Begin

**Read this entire manual.**

This section is provided for the assistance of qualified and trained service technicians only and is not intended for use by untrained or unauthorized service personnel. This section is not a replacement for the SEW Eurodrive instructions. Additional resources and information can be found at [www.seweurodrive.com/support](http://www.seweurodrive.com/support) or confirm current information with SEW Eurodrive by calling 1-888-SEW-3876 and reference your serial number.

### NOTICE

A qualified person is defined as a person who, by possession of a recognized degree or certificate of professional standing, or by extensive knowledge, training, and experience, has successfully demonstrated his/her ability to solve problems relating to the subject matter and work.

Personnel to carry out work on the motor or brake must exclusively be qualified personnel who - based upon their education, experience, instructions as well as knowledge concerning relevant standards and provisions, accident prevention, regulations and operating conditions - have been authorized by the person being responsible for safety, to carry out the activities described in these instructions and who - when doing so - are in a position to recognize possible risks early and to avoid them.

## Safety Information



### **DANGER**



High Voltage! Installation or maintenance work may only be performed when no power is available to the motor. Electric motors, electrical brakes, and variable frequency drives contain potentially dangerous high-voltage. Shut down the power at the circuit breaker or power switch. Employees servicing or maintaining VRCs may be exposed to death or serious personal injury if hazardous energy is not properly controlled. De-energize any circuit before work is begun. Do not touch live components or power connections immediately after disconnecting the device from the voltage supply because some capacitors may still be charged. Adhere to a minimum switch-off time of 10 minutes. Observe the corresponding labels on the device. Follow your facilities procedures or OSHA lockout/tagout (LOTO) procedures anytime maintenance or service is being performed on any electrical box or component.



Burn Hazard! Surfaces of motors and gear units may become hot during operation or shortly after start-up. In some instances additional protection against accidental contact may be necessary. Use caution to avoid burns or serious injury! Let the motor cool before work begins.

- Keep clear of unsupported platforms. Stay out of the area under a raised platform. If a maintenance operation requires the carriage to remain in the raised position, physically secure the carriage at the upper level using adequately sized maintenance chains, maintenance pins, DeckLocks, or straps with shackles around the drivebase that are capable of supporting the weight of the carriage to provide additional safety.

### NOTICE

Voltage to the brake must be applied and removed at the same time as the power to the motor.

## Brake Running Operation

Without any malfunctions occurring, the running operation does not require any maintenance except for a visual inspection of the brake disc lining, visual inspection of the pressure plates, and verifying the size of the air gap. See Figure 11-1. The air gap increases as the lining on the rotor wears. When the maximum air gap is reached, an adjustment of the air gap is required for the safe operation of the brake. The functional capability and safety function of the brake will be compromised as additional wear occurs and must be replaced. Inspections must be verified in accordance with the following schedule.

Inspection intervals:

Holding brake: At least every six months  
Use shorter intervals in case of frequent emergency stops

## Brake Maintenance

1. Remove cover.
2. Slide the rubber seal to the side to expose the stationary disc and brass shim.
3. Visually inspect the brake disc for damage.
4. Visually inspect the pressure plates for discoloration.
5. Measure the air gap with a feeler gauge at **three different positions around the brake** between the stationary disc and the coil. [See the next page for the appropriate measurement or confirm current information with SEW Eurodrive by calling 1-888-SEW-3876 and reference your serial number.]

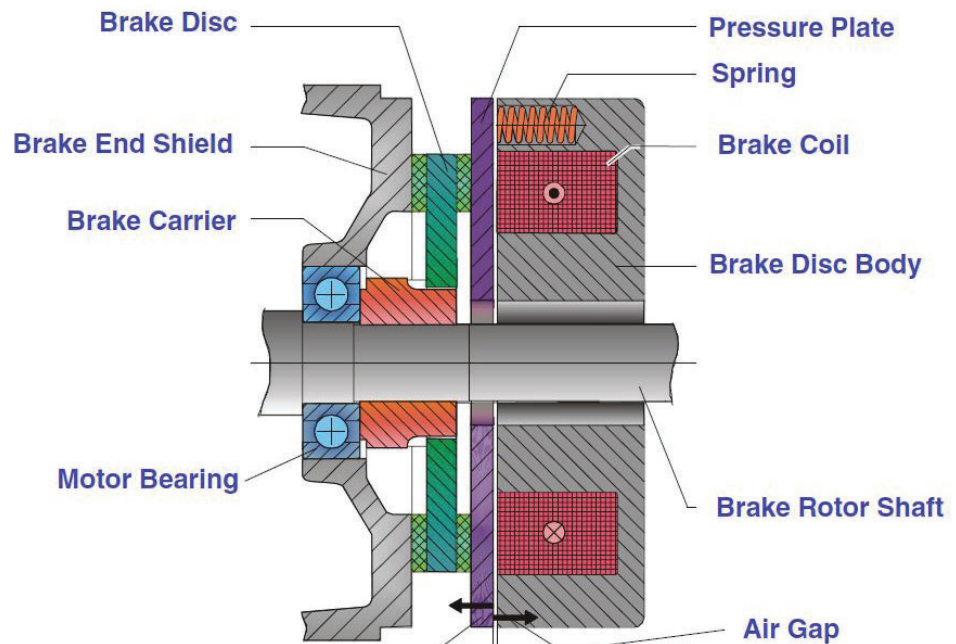

Air Gap Location  
Figure 11-1



**Air Gap Values**

Brake	Working air gap		Brake lining carrier
	min. <sup>2)</sup>	max.	Min.
	mm	mm	mm
BE03	0.25	0.65	— <sup>3)</sup>
BE05	0.25	0.6	11.0
BE1	0.25	0.6	11.0
BE2	0.25	0.6	11.0
BE5	0.25	0.9	11.0
BE11	0.3	1.2	12.5
BE20	0.3	1.2	12.5
BE30	0.3	1.2	12.5
BE32	0.4	1.2	12.5
BE60	0.3	1.2	14.0
BE62	0.4	1.2	14.0
BE120	0.6	1.2	14.0
BE122	0.8	1.2	14.0

- 1) The specified values are nominal values that were determined during rating operation. The actual braking work that can be reached before maintenance may vary depending on the actual load during operation.
- 2) When checking the working air gap, note that parallelism tolerance on the brake disk may give rise to deviations of +/-0.15 mm after a test run.
- 3) The brake lining carrier of the BE03 can not be replaced. Replace the brake when the maximum working air gap is reached.

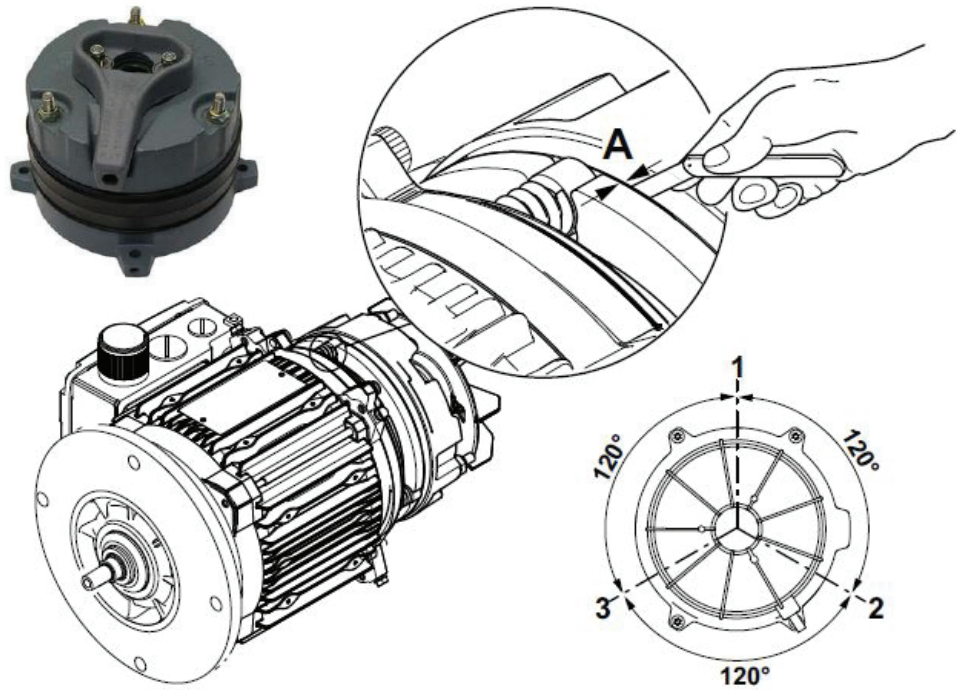

Feeler Gauge Positions  
Figure 11-2

**Adjust the  
Air Gap (if  
needed)**

Any adjustment to the air gap will also affect the play in the manual release.

Tighten or loosen the adjusting nuts equally and evenly around the brake as needed. Continue to measure the air gap with a feeler gauge at **three different positions around the brake** between the stationary disc and the coil until the minimal air gap clearance is reached. See Figure 11-3.

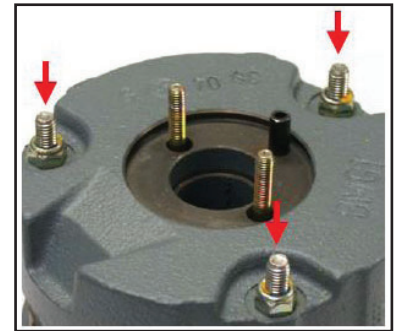

Adjusting Nuts  
Figure 11-3



**Troubleshooting the Motor**

The following table identifies some of the most common issues with speed reducers, the possible causes, and the suggested solution.

<b>Malfunction</b>	<b>Possible Cause</b>	<b>Solution</b>
<b>Motor does not start</b>	Supply cable interrupted.	Verify the connections and intermediate terminal points. Correct if necessary.
	Brake does not release.	Review brake troubleshooting.
	Supply cable fuse has blown.	Replace fuse.
	Motor protection switch has triggered.	Verify that the motor protection switch is set correctly. Refer to the specification on the nameplate.
	Motor protection does not trip.	Inspect motor protection control.
	Malfunction in control or in the control process.	Observe switching sequence. Correct if necessary.
<b>Motor only starts with difficulty or does not start at all</b>	Motor power designed for delta connection but connected in Y.	Correct the connection from Y to delta. Refer to the wiring diagram.
	Motor power designed for YY connection but only connected to Y.	Correct the connection from Y to YY. Refer to the wiring diagram.
	Voltage or frequency differs considerably from the setpoint, at least when switch on the motor.	Provide better supply system. Reduce the power supply load. Inspect cross section of supply cable. Replace with cable or larger cross section if necessary.
<b>Motor does not start in Y connection, only in delta connection</b>	Y connection does not provide sufficient torque.	If the delta inrush current is not too high (observe the regulations of the power supplier), start up directly in delta.
	Contact fault on Y/delta switch.	Inspect the switch. Replace if necessary. Inspect the wire connections.
<b>Incorrect direction of rotation</b>	Motor connected incorrectly.	Swap 2 phases of the motor supply cable.
<b>Motor hums and has high current consumption</b>	Brake does not release.	Review brake troubleshooting.
	Winding is defective.	Send motor to specialist workshop for repair.
	Rotor is rubbing.	Send motor to specialist workshop for repair.
<b>Fuses blow or motor protection trips immediately</b>	Short circuit in the motor supply cable.	Eliminate short circuit.
	Supply cables connected incorrectly.	Correct the connection. Refer to the wiring diagram.
	Short circuit in the motor.	Send motor to specialist workshop for repair.
	Ground fault on motor.	Send motor to specialist workshop for repair.



**Troubleshooting the Brake**

The following table includes typical problems during the operation of the brake, the possible causes, and instructions on how to solve the problem.

<b>Malfunction</b>	<b>Possible Cause</b>	<b>Solution</b>
<b>Brake does not release</b>	Incorrect voltage on brake control unit.	Inspect the nameplate and apply the correct voltage.
	Brake control unit failed.	Renew brake control, inspect resistors and isolation of the brake coils. Inspect switchgear, replace if necessary.
	Air gap is too large because the brake lining is worn.	Inspect and adjust working air gap. Inspect brake disc and replace the entire brake lining carrier if needed.
	Voltage drop along supply cable >10%.	Inspect the nameplate and apply the correct voltage. Inspect the cross section of the brake supply cable, increase cross section if necessary.
	Inadequate cooling, brake over-heating.	Provide cooling air supply or clear cooling air passages, inspect air filter, clean or replace if necessary. Replace type BG brake rectifier with type BGE.
	Brake coil has interturn short circuit or a short circuit to frame.	Inspect resistors and isolation of the brake coils.
		Replace complete brake and brake control (specialist workshop). Inspect switchgear and replace if necessary.
Rectifier is defective.	Replace rectifier and brake coil [it may be more cost effective to replace the complete brake].	
<b>Brake does not brake</b>	Brake locked by manual brake release HF.	Loosen the set screw, remove if needed.
	Working air gap so large that setting nuts for the manual release come into contact.	Set the working air gap.
	Manual brake release device not set correctly.	Set the setting nuts for the manual release correctly.
	Working air gap not correct.	Measure and set the working air gap.
	Brake lining worn.	Inspect brake disc and replace the entire brake lining carrier.
	Incorrect braking torque.	Inspect the dimensioning and, if necessary, change brake torque by type and number of brake spring, or by selecting a different brake.
<b>Brake application is delayed</b>	Brake is switched only on AC voltage side.	Switch both the DC and AC circuits; inspect wiring diagram.



## Removing the Brake



## Disposal of the Brake and Gear Motor

The brake can only be removed after power has been disconnected from the VRC, the brake and motor has been de-energized, and the brake is torque-free.

### **DANGER**



High Voltage! Employees servicing or maintaining VRCs may be exposed to death or serious personal injury if hazardous energy is not properly controlled. De-energize any circuit before work is begun. Do not touch live components or power connections immediately after disconnecting the device from the voltage supply because some capacitors may still be charged. Adhere to a minimum switch-off time of 10 minutes. Observe the corresponding labels on the device. Follow your facilities procedures or OSHA lockout/tagout (LOTO) procedures anytime maintenance or service is being performed on any electrical box or component.

Because of the different material components, the components of our spring-applied brakes and gear motors must be disposed of and recycled separately. Follow official regulations.

- Iron
- Aluminum
- Copper
- Plastics
- Electronic parts
- Oil and grease (not mixed with solvents)





---

**NOTICE** Improper oil levels may lead to premature component wear and diminished service life. The gear reducer may not receive proper lubrication if the unit is not mounted in the position for which it is designed.

---

Do not weld on the gear unit or use the gear unit as an earth or ground connection for any welding procedure as this may cause permanent damage to the bearings and gears.

---

Unless special measures are taken, the immediate vicinity around the gear drive or motor should not be exposed to any aggressive or corrosive substances, contaminated air, ozone, gases, solvents, acids, alkalis, salts, radioactivity, etc.

---

The single shaft key must engage the full bore-land length at each end of the hollow shaft.

## Gear Unit Lubrication

---

Proper gear unit lubrication is essential in order to reduce friction, heat, and component wear. Lubricants reduce heat and wear by inserting a protective “fluid boundary” between mating parts and preventing direct metal to metal contact. Lubricants also help prevent corrosion and oxidation, minimize foam, improve heat transfer, optimize reducer efficiency, absorb shock loads and reduce noise.

Most gear units are shipped from the factory with a pre-determined oil fill level in accordance to the specified gear unit size and mounting position.

---

**NOTE** *Consult the sticker adjacent to the fill plug to determine the type of lubricant installed at the factory. Some units have special lubricants designed to operate in certain environments or intended to extend the service life or service temperature range of the lubricant. If in doubt about which lubricant is needed for a certain application, please contact the PFlow Industries, Inc. Customer Support Department.*

## Lubricant Replacement

---

If the gear unit is filled with mineral oil, replace the lubricant at least after every 10,000 operating hours or after every two years. If the gear unit is filled with synthetic oil, replace the lubricant at least after every 20,000 operating hours or after every four years. Often gear units are exposed to extreme ambient conditions, hostile environments, wet conditions, or dirty and dusty operating areas. Especially in these situations, it is important to establish a condition-based oil service interval.

## Maximum Oil Temperature

---

To prevent gear unit from overheating, the maximum oil sump temperature limit of the gear unit must not be exceeded for prolonged periods of operation (up to 3 hours continuous operation depending upon gear unit size). Application limits are specified on the gear unit nameplate.

---





### Lubrication Notes

- Food-grade lubricants must be in compliance with FDA 212 CFR 178.3570 and qualify as an NSF-H1 lubricant. Please consult with lubrication manufacturer for more information.
- When making a lubrication change, verify with the lubrication supplier to assure compatibility and to obtain recommended cleaning or flushing procedures.
- Make sure not to mix different oils with different additive packages or different base oil formulation types. Polyglycol (PG) oils are not capable of being mixed with other oil types and should never be mixed with mineral oil or polyalphaolefin (PAO) synthetic oil.

### Oil Volume

Gear units are shipped from the factory with a pre-determined oil fill level in accordance to the specified reducer size and mounting position.

Actual oil volume can vary slightly depending upon the gear case size, mounting, and ratio. Prior to starting the reducer, check the oil fill level using the reducer's oil level plug and drain or add oil as needed.

### Changing the Oil

1. Determine the position of the oil level plug and the breather valve. Refer to the next page.
2. Place a container under the oil drain plug.
3. Slowly remove the oil level plug. Small amounts of oil may leak out if the permitted maximum oil level is higher than the lower edge of the oil level bore.
4. Remove the breather valve and the oil drain plug.
5. Drain the oil completely.
6. Re-insert the oil drain plug.
7. Fill with fresh oil of the same type via the breather bore. Do not mix different synthetic lubricants. Observe the oil quantity according to the specifications on the nameplate.
8. Re-insert the oil level plug and the breather valve.

### Lubricant Table

Brand	Product	ISO, NLGI	DIN (ISO)	Temperature (°C)	Mounting
TOTAL	Carter EP 220	VG 220	CLP PG	+80	R..
FUCHS	Renolin CLP 220	VG 220	CLP PG	+80	K37-187 (HK..)
FUCHS	Renolin P-G 220	VG 220	CLP PG	+60	F..
FUCHS	Renolin Unisyn CLP 220	VG 220	CLP PG	+40	
FUCHS	Renolin Unisyn CLP 150	VG 150	CLP PG	+25	
Castrol	Optimol Optigear BM 220	VG 220	CLP PG	+40	
Castrol	Optiflex A 220	VG 220	CLP PG	+20	
Castrol	Optigear Synthetic X 220	VG 220	CLP PG	+20	
Castrol	Optigear Synthetic X 150	VG 150	CLP PG	+20	
Castrol	Optigear BM 100	VG 68	CLP PG	+0	
Tribol	Tribol 1100/220	VG 220	CLP PG	+40	
Tribol	Tribol 800/220	VG 220	CLP PG	+20	
Tribol	Tribol 1510/220	VG 220	CLP PG	+20	
TEARCO	Meropa 220	VG 220	CLP PG	+40	
TEARCO	Synlube CLP 220	VG 220	CLP PG	+20	
TEARCO	Pinnacle EP 220	VG 220	CLP PG	+20	
TEARCO	Pinnacle EP 150	VG 150	CLP PG	+20	
TEARCO	Meropa 150	VG 68	CLP PG	+0	
KLUBER	Klüberoil GEM 1-220 N	VG 220	CLP PG	+40	
KLUBER	Klübersyn GH 6-220	VG 220	CLP PG	+20	
KLUBER	Klübersyn GEM 4-220 N	VG 220	CLP PG	+20	
KLUBER	Klübersyn GEM 4-150 N	VG 150	CLP PG	+20	
KLUBER	Klüberoil GEM 1-150 N	VG 150	CLP PG	+20	
KLUBER	Klüber-Summit HySyn FG-32	VG 32	CLP PG	+0	
bp	BP Energol GR-XP 220	VG 220	CLP PG	+40	
bp	BP Energol SG-XP 220	VG 220	CLP PG	+20	
Shell	Shell Omala S2 G 220	VG 220	CLP PG	+40	
Shell	Shell Omala S4 WE 220	VG 220	CLP PG	+20	
Shell	Shell Omala S4 GX 220	VG 220	CLP PG	+20	
Shell	Shell Omala S4 GX 150	VG 150	CLP PG	+20	
Shell	Shell Omala S2 G 150	VG 150	CLP PG	+20	
Shell	Shell Omala S4 GX 68	VG 68	CLP PG	+0	
Mobil	Mobilgear 600 XP 220	VG 220	CLP PG	+40	
Mobil	Mobil Glycoyle 220	VG 220	CLP PG	+20	
Mobil	Mobil SHC 630	VG 220	CLP PG	+20	
Mobil	Mobil SHC 629	VG 150	CLP PG	+20	
Mobil	Mobilgear 600 XP 150	VG 150	CLP PG	+20	
Mobil	Mobil SHC 626	VG 68	CLP PG	+0	
Mobil	Mobil SHC 624	VG 32	CLP PG	+0	

**Oil Plug Connections**

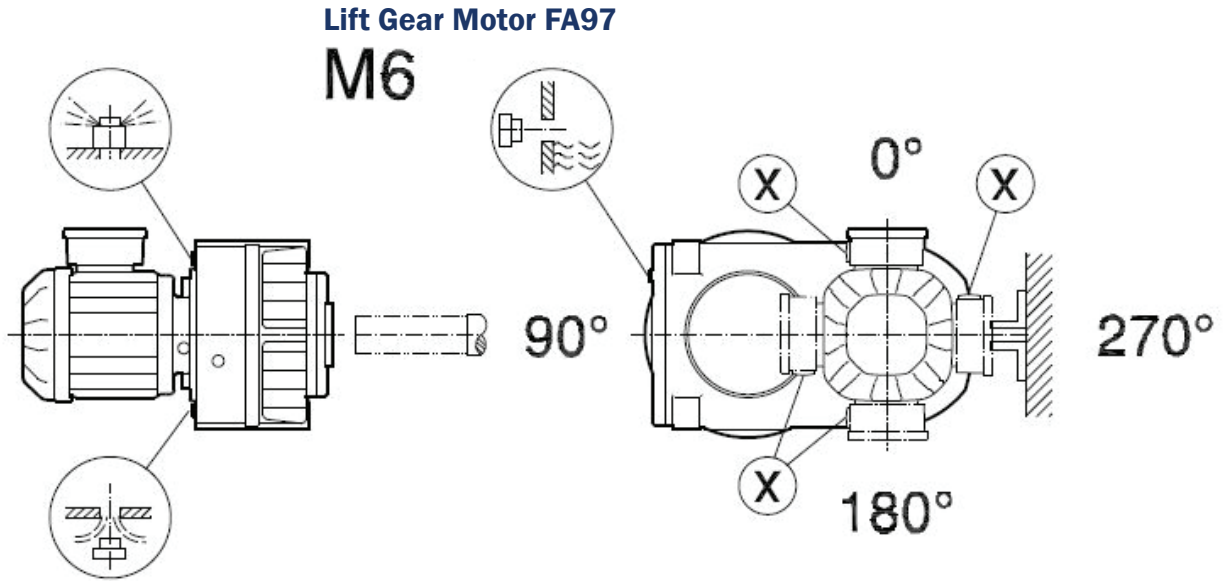

Icon	
	<b>Breather Valve</b>
	<b>Oil Level Plug</b>
	<b>Oil Drain Plug</b>

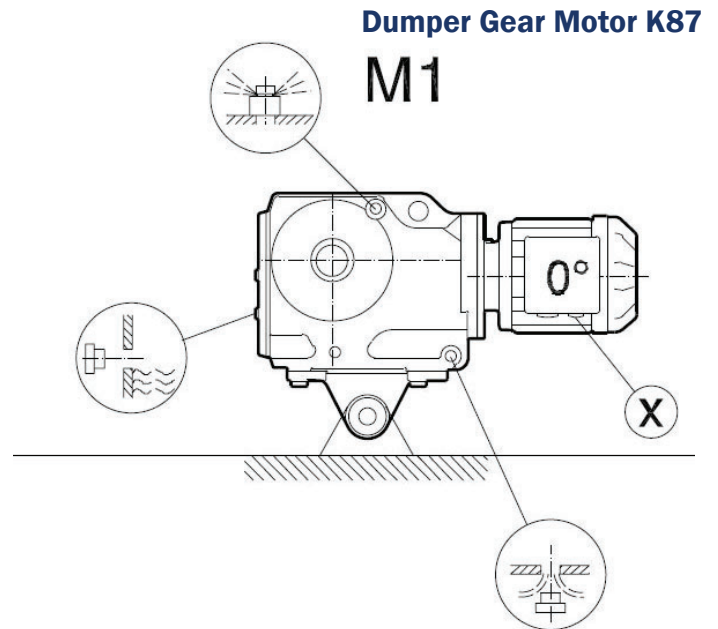

Oil Plug Locations  
Figure 11-4



**⚠ WARNING**

- Do not use any corrosive or flammable solvents or cleaning agents on the machine that contain TRI, PER, TETRA, or FCHC. Read the instructions on the packaging when use is made of chemical substances (cleaning agents).
- Electrical components should not make contact with water or other liquids.
- Do not clean the VRC or any of its components with compressed air or water under high pressure.
- Do not use abrasive steel pads, wire brushes, or scrapers when cleaning.
- Avoid parts made of rubber or plastic, such as cables and gaskets, from making contact with oil, solvents, or other chemicals.
- Climbing, sitting, walking, or riding on equipment while the equipment is in operation could result in death or serious injury.
- Close all gates before the carriage is moved. Never leave the VRC unattended with the gates in the open position. Never close gates when a person is on the carriage or within the fenced area.
- The most common reason for access to the area beneath the carriage is to remove debris from the pit. This is best accomplished using a long handled broom or rake to avoid entering the pit under the raised carriage deck. Only qualified person following proper lockout/tagout procedures with the carriage properly secured in a raised position are permitted to access the pit or hoistway enclosure at the bottom level. Refer to Bulletin 15709-0083 for additional information.
- Entanglement hazard! Secure long hair, wear snug-fitting clothing, and avoid wearing jewelry while using the VRC.



**Cleaning**

1. Remove all product from the VRC carriage.
2. Lockout the VRC in accordance with the facility Lockout/Tagout program.
3. Remove spills and dirt by hand.
4. Refer to Bulletin 15709-0083 for additional information on procedures to access the area beneath the carriage to remove debris from beneath the carriage.
5. Report any unsafe condition or damage to the personnel responsible for the VRC and make sure that any damage is remedied before restarting the VRC. Do not allow the VRC to operate when unsafe conditions arise.







The VRC requires minimal attention on a regular basis to prevent equipment failures or accelerated wear and tear. VRCs operating during multiple daily shifts need to be maintained more often. This section is provided for the assistance of qualified and trained service technicians only and is not intended for use by untrained or unauthorized service personnel. Make sure all steps are completed. A record of regular, properly conducted preventive maintenance provides a running history of any issues the VRC may have. The reports will identify trends, and helps anticipate expected wear and tear repairs. Sign and return to PFlow Industries, Inc. Customer Support Department via e-mail to [csd@pflow.com](mailto:csd@pflow.com)

**NOTICE**

A qualified person is defined as a person who, by possession of a recognized degree or certificate of professional standing, or by extensive knowledge, training, and experience, has successfully demonstrated his/her ability to solve problems relating to the subject matter and work.

**WARNING**



- If any defects relating to operating safety and reliability are detected or if any damage occurs, the VRC must be taken out of operation immediately.
- Lockout/tagout the VRC before performing any maintenance. De-energize any circuit before work is begun.
- Take appropriate measures for safely working at heights.
- Make sure that no persons or objects are within the range of any moving parts of the VRC.
- Climbing, sitting, walking, or riding on equipment while the equipment is in operation could result in death or serious injury.
- If this VRC needs to be modified in any way, contact PFlow Industries, Inc. for assistance. Do not make any unauthorized changes.
- Before the VRC is put into operation, all VRC parts must comply with all relevant health and safety directives and regulations.
- Close all gates before the carriage is moved. Never leave the lift unattended with the gates in the open position. Never close gates when a person is on the carriage or within the fenced area.
- Entanglement hazard! Secure long hair, wear snug-fitting clothing, and avoid wearing jewelry while using the VRC.

## Section 13 | F Series Preventive Maintenance and Schedule Checklist



MATERIAL HANDLING SOLUTIONS

www.pflow.com  
 P 414 352 9000  
 F 414 352 9002  
 6720 N. Teutonia Ave.  
 Milwaukee, WI 53209

✓	Action	How Often
	Verify overall operation.	monthly
	Verify that all level stops are flush with the floor level. Adjust as necessary.	monthly
	Verify that all areas under and around the VRC are clean.	monthly
	Verify that all gates and interlocks are functioning properly.	monthly
	Verify that all electrical components are undamaged.	monthly
	Verify that all gates and enclosures are undamaged and properly installed.	monthly
	Verify that all push-button stations and e-stops are functioning on each level.	monthly
	Identify any unsafe condition. Document and report the condition immediately to the customer and then PFlow Industries, Inc. Customer Support Department. Do not allow the VRC to operate when unsafe conditions arise.	monthly
	Verify that all nuts and bolts are tight. Adjust as necessary.	3 months
	Verify that all moving components are functioning properly.	3 months
	Inspect and lubricate all chains (e.g., lift, drive, tensioner, gate) with non-detergent, petroleum-based SAE 30 oil. Inspect for wear, rust, bent, cracked, or binding links.	3 months
	Inspect limit switches and operation. Adjust as necessary.	3 months
	Verify that the lift chain sprocket position is centered over the chain tube. Adjust the position if necessary. Apply Loctite® Blue #242® Threadlocker to the sprocket setscrews and split collar setscrews. Tighten and torque setscrews.	3 months
	Verify that the drive sprocket position is aligned with the face of the column sprocket. Adjust the position if necessary. Apply Loctite® Blue #242® Threadlocker to the setscrews. Tighten and torque setscrews.	3 months
	Inspect all additional options and accessories (e.g., DeckLocks, maintenance pins) and operation. Adjust as necessary.	3 months
	Inspect the wheelblock guide rollers for rotation interference and wear.	3 months
	Verify that all electrical connections are tight.	3 months
	Verify that all tensioners are properly adjusted. Adjust as necessary.	3 months
	Verify that the carriage is level. Adjust as necessary.	6 months
	Inspect all welding, bracing, and anchoring for structural integrity.	6 months
	Inspect all chain sprockets for wear.	6 months
	Lubricate the pillow block bearings on the drivebase with lithium axle grease. Apply Loctite® Blue #242® Threadlocker to the setscrews. Tighten and torque setscrews.	6 months
	Inspect the gear reducer oil level and replenish as necessary. The minimum acceptable oil level is 0.15" (4mm) below the oil level hole.	6 months
	Inspect the motor and brake. Measure and record the air gap on the brake.	12 months
	Inspect the twin roller guides, rear wheelblocks, and safety cams for deterioration.	12 months
	Replace gear reducer mineral oil every 10,000 operating hours or every two years.	2 years
	Replace gear reducer synthetic oil every 20,000 operating hours or every four years.	4 years

### Additional Notes or Follow-up Requirements

Customer signature:	Date work completed:
Name/Phone:	Authorized Technician(s):
Title:	Name:
E-mail:	Name:



## Before You Begin

**Read this entire manual before any troubleshooting and service is attempted on the Vertical Reciprocating Conveyor (VRC).**

Service must be performed only by qualified and trained service technicians familiar with the safe operation of this equipment.

### NOTICE

A qualified person is defined as a person who, by possession of a recognized degree or certificate of professional standing, or by extensive knowledge, training, and experience, has successfully demonstrated his/her ability to solve problems relating to the subject matter and work.

Personnel to carry out work on the VRC must exclusively be qualified personnel who - based upon their education, experience, instructions as well as knowledge concerning relevant standards and provisions, accident prevention, regulations and operating conditions - have been authorized by the person being responsible for safety, to carry out the activities described in these instructions and who - when doing so - are in a position to recognize possible risks early and to avoid them.

## DANGER



- High Voltage! A licensed electrician must install all electrical connections and permanent wiring in accordance with applicable local or national electrical codes. Make sure the equipment is properly grounded in accordance with local electrical codes or, in the absence of local codes, with the current edition of the National Electrical Code NFPA No. 70.
- Keep clear of unsupported platforms. Stay out of the area under a raised platform. If a maintenance operation requires the carriage to remain in the raised position, use a means of support such as adequately sized maintenance chains, maintenance pins, DeckLocks, or straps with shackles around the drivebase that are capable of supporting the weight of the carriage. Refer to Bulletin 15709-0083 for additional information.

## WARNING



- Assess the VRC and identify any potential load jams.
- Lockout/tagout equipment before performing any adjustments or maintenance. If the equipment is not locked out, it could start unexpectedly and cause injury or damage. **Make sure all personnel are aware of the potential for stored energy to be present even after the power has been locked out.** Refer to ANSI Z244.1 and OSHA 29 CFR 1910.147 for minimum requirements for a lockout/tagout system. There may be additional state or local requirements.
- Toppling Hazard! Secure all VRC components (e.g., lift chain, gate panels, enclosure panels) that may fall during the troubleshooting process.
- Falling Hazard! Secure all VRC access areas (e.g., gates, push-button stations) before any troubleshooting or service is begun. Never leave the VRC unattended with the gates in the open position. Never close gates when a person is on the carriage or within the fenced area.





The following table identifies some of the most common issues with the VRC, the possible causes, and the suggested solution.

Malfunction	Possible Cause	Solution
<b>Push-button controls do not start the motor.</b>	The emergency stop is pushed in.	Pull the emergency stop out.
	Gates or doors are open or ajar.	Verify that all gates and doors are closed.
	Proofed diagonal drop bar on the carriage is up.	Lower the drop bar into position.
	Main power disconnect is off.	Verify that there is a reason the power is off before turning the power on.
	Thermal overload has tripped.	Press the reset button. If it trips again, determine the cause. The motor is overheating.
	Control fuse is blown.	Investigate if the problem is related to the main power fuses or the control fuses. Correct the problem and replace the fuse.
	Power circuit between the disconnect and starter is dead.	Using a voltmeter, measure the voltage. Repair as needed.
	Loose lift chain or tensioner chain.	Tighten the chain or adjust the chain tensioner or chain sensor.
	Broken tensioner chain.	Repair or replace as needed.
<b>Motor starts and carriage raises, but motor stops before the second level.</b>	A switch on the DeckLock is not functioning properly.	Investigate the DeckLock switches and repair as needed.
	Gates or doors are open or ajar.	Close the gate or door. Inspect the door magnets and interlock. Adjust as needed.
	Object encountered.	Identify the problem. Remove or repair as needed.
	Drive component interference.	Remove object. Repair if needed.
	OCS relay has tripped.	Lower and remove excessive weight. Inspect brake for possible malfunction, excessive ambient temperature, or mechanical binding.
	Loose lift chain or tensioner chain.	Tighten the chain or adjust the chain tensioner or chain sensor.
Broken tensioner chain.	Repair or replace chain as needed.	





<b>Malfunction</b>	<b>Possible Cause</b>	<b>Solution</b>
<b>Lift motor starts for two seconds and stops.</b>	Overcurrent sensor or motor overload trips.	Lighten the lifted load.
<b>Carriage fails to stop at floor level.</b>	Floor level limit switch is inoperable.	Adjust, repair, or replace the floor level limit switch.
	Brake inoperable.	Determine cause and effect. Repair if needed.
<b>Carriage raises but will not lower.</b>	Safety cam has set.	Identify the problem and repair as needed.
<b>Carriage lowers but stops early.</b>	Debris in the pit.	Remove debris from pit and clean the area.
<b>Rough or noisy operation.</b>	Interference between the chain and chain guards or chain guides.	Determine the cause and correct.
	Shaft pillow block bearings are worn or dry.	Inspect, lubricate, and replace as needed.
	Motor / reducer.	Determine the cause and correct.
	Travel interference.	Identify the problem, remove, and repair as needed.
	Drive component interference.	Identify the problem, remove, and repair as needed.
	Wheel guide rollers are worn.	Inspect and replace as needed. Determine the cause and correct.
	Wheelblock guide shoe is rubbing on main beams.	Determine the cause and correct.
	Chain tensioner sprocket bushing is worn or corroded.	Inspect and replace as needed.
Carriage is not level.	Determine the cause and correct.	
<b>Motor hums but shaft does not rotate, then thermal overload trips.</b>	Single phasing.	Use a voltmeter to ensure the incoming main leads are wired properly. Repair as needed.





**Before You Begin**

*Read this entire manual.*

**Overcurrent Sensor (OCS) Purpose**

The PFlow Industries, Inc. Vertical Reciprocating Conveyor (VRC) is equipped with an Overcurrent Sensor (OCS). The OCS is pre wired and located inside the electrical control panel. See Figure 15-1.

The OCS monitors the motor amp draw and provides enhanced over current protection of the lift motor. The OCS must be adjusted to the maximum “expected” current draw. If the motor current rises above the OCS set point, the OCS will trip. Tripping can be caused by a circuit malfunction, overloading the capacity of the lift, or an overhanging load trapped between floors.



Overcurrent Sensor Figure 15-1

**Test and Calibrate the OCS**

1. Turn the trip point dial to its lowest position.
2. Place the maximum product weight on the carriage.

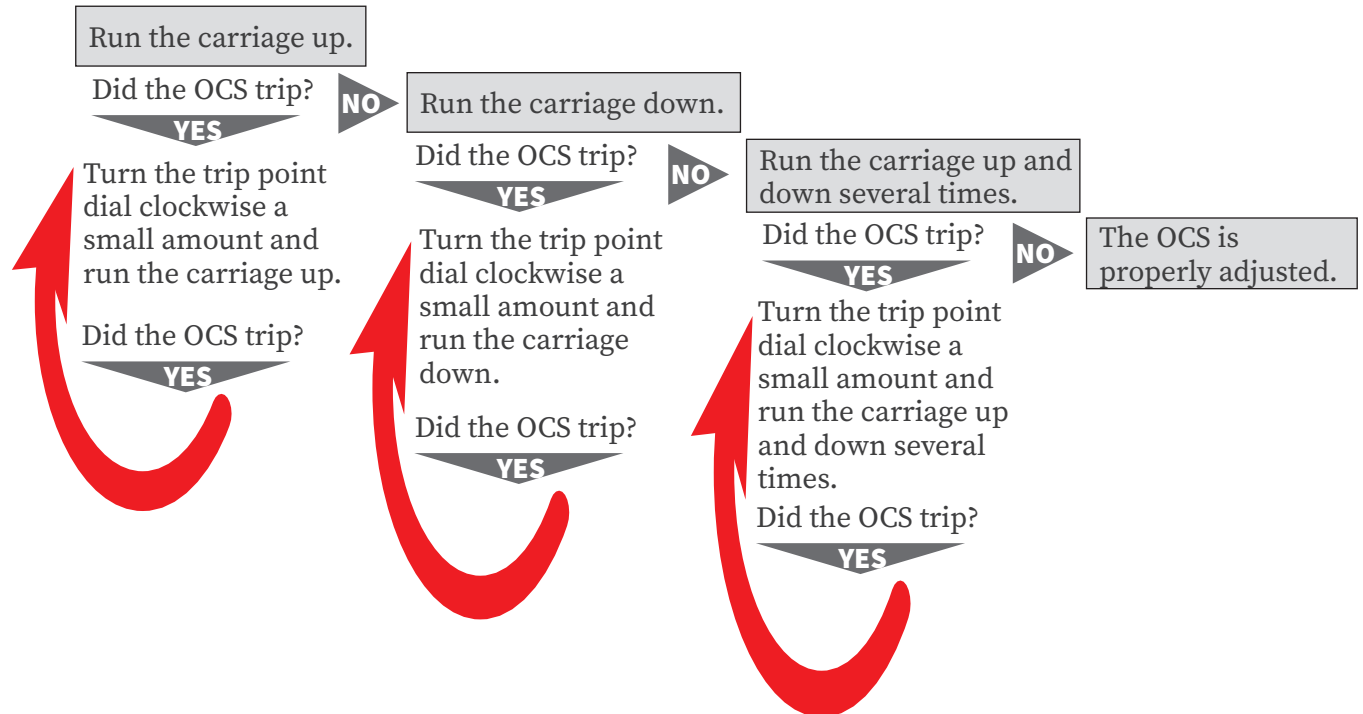

## Section 15 | Adjust Overcurrent Sensor



**MATERIAL HANDLING SOLUTIONS**

[www.pflow.com](http://www.pflow.com)  
P 414 352 9000  
F 414 352 9002  
6720 N. Teutonia Ave.  
Milwaukee, WI 53209



## Section 16 | Recommended Spare Parts F Series



MATERIAL HANDLING SOLUTIONS

www.pflow.com  
P 414 352 9000  
F 414 352 9002  
6720 N. Teutonia Ave.  
Milwaukee, WI 53209

This recommended spare parts list is generic (not specific to your unit). Part numbers are deleted due to variables specific to each application. This list is a guide to assist the customer in establishing an emergency inventory for your PFlow Industries, Inc. VRC. Convenience and minimal down time are two good reasons to maintain an inventory of spare parts. This list does not imply that any part is subject to failure. However, should any of these parts fail, they could put the VRC out of service.

Description	Quantity	Part Number
<b>Roller Guide Wheelblocks</b>		
<b>(choose one material type)</b>		
Wheel, Nyloil (green), 3-1/2	4	
Wheel, Polyurethane (red), 3-1/2	4	
Wheel, Steel, 3-1/2	4	
Pin, 30mm	4	
Plate, Retainer	4	
Roller, Guide, 1.25 OD	8	
Bolt, Shoulder, 1/2 x 1 3/4	8	
<b>Push-Button Stations</b>		
PB Station, 2-LVL, 22mm	1	
Emergency Stop (E-Stop)	1	
Operator Push-Button Black Flush	1	
<b>General</b>		
Paint 13 oz. PFlow Blue Aerosol Spray	1	
<b>Electrical Components</b>		
Fuse, 0.8A, 600V, Class CC, Time Delay	5	
Fuse, 1A, 250V, Time Delay	5	
Fuse, 2A, 250V, Non-Time Delay	5	
<b>Chains and Chain Tensioners</b>		
S Hook	4	
Swivel Round Eye Double	4	
Link, Master, #35, SBR	4	

Part numbers in this manual are subject to change or correction without notice. Minimum order charge is \$50, FOB Milwaukee, Wisconsin. Components replaced under warranty will be charged for in accordance with our RMA procedures. PFlow Industries, Inc. Customer Support Department must issue an authorization in advance of any claim for warranty and/or warranty labor. This list is based on the job as manufactured and shipped new from PFlow Industries, Inc. Any changes, updates, parts by others, or modifications after shipment are unknown to PFlow Industries, Inc.

**Section 16 | Recommended Spare Parts  
F Series**



**MATERIAL HANDLING SOLUTIONS**

[www.pflow.com](http://www.pflow.com)  
P 414 352 9000  
F 414 352 9002  
6720 N. Teutonia Ave.  
Milwaukee, WI 53209



**Before You Begin**

Part numbers in this manual are subject to change without notice. Components replaced under warranty will be charged for in accordance with our RMA procedures. Minimum order charge is \$35, FOB Milwaukee, Wisconsin.

**Drivebase Assembly**

These are custom-designed components and vary by job. To ensure correct replacement components are used, consult the PFlow Industries, Inc. Customer Support Department for proper part numbers. Please send a photo of the SO number from the reducer assembly and have the PFlow serial number available when requesting this information.

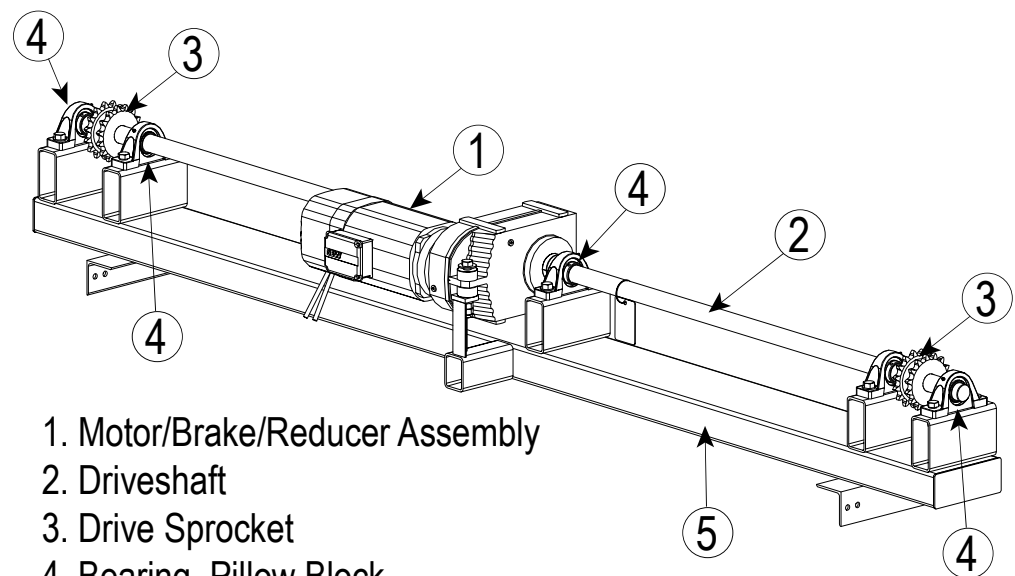

- 1. Motor/Brake/Reducer Assembly
- 2. Driveshaft
- 3. Drive Sprocket
- 4. Bearing, Pillow Block
- 5. Drivebase Weldment

10308-0002.SMG  
 PFL-180911-3



**Chain Arrangement**

The following drawings illustrate the path of the lift chain and tensioner chain. **The size of the drive and the chains vary by application. Consult PFlow Industries, Inc. Customer Support Department before ordering.**

Item	Qty	Part No.	Description
1	1	2693-1000	Chain, #100, SBR
	1	2693-6100	Chain, #100, HSP
	1	4102-1000	Chain, #120, SBR
	1	4102-6100	Chain, #120, HSP
	1	7880-1000	Chain, #140, SBR
	1	7880-6100	Chain, #140, HSP
2	2	2693-1001	Master Link, #100 Chain, SBR
	2	2693-6101	Master Link, #100 Chain, HSP
	2	4102-1001	Master Link, #120 Chain, SBR
	2	4102-6101	Master Link, #120 Chain, HSP
	2	7880-1001	Master Link, #140 Chain, SBR
	2	7880-6101	Master Link, #140 Chain, HSP
3	2	7651-0000	Swivel, Round Eye Double
4	2	7938-1001	Master Link, #35 Chain
5	2	7938-0000	Chain, #35 x Length
6	2	3715-0000	"S" Hook
7	1	6189-0000	Toggle, #100 Chain
	1	6188-0000	Toggle, #120 Chain
	1	7924-0000	Toggle, #140 Chain
8	2	6187-0000	Safety Cam Link, Untreated
	2	6187-0001	Safety Cam Link, Treated

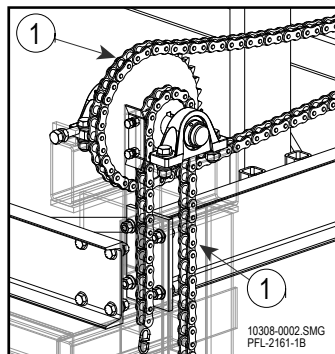
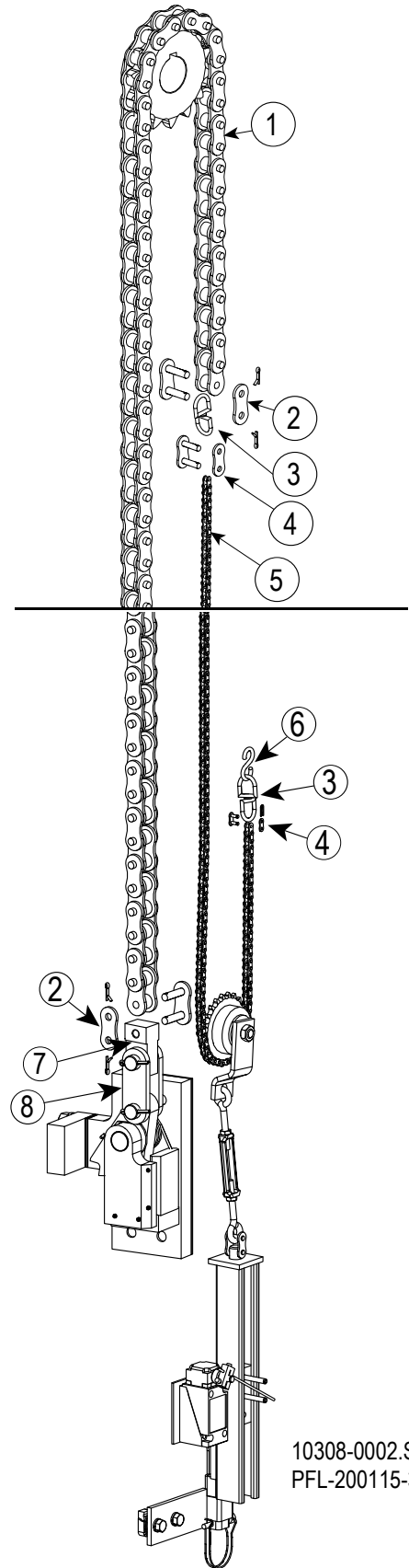

10308-0002.SMG  
 PFL-200115-3



**Chain Tensioner Assembly**

Item	Qty	Part No.	Description
	1	10101-0000	Chain Tensioner Assembly with Right-hand Bracket, Single Pole Limit Switch, and Limit Switch Arm
	1	10101-0001	Chain Tensioner Assembly with Left-hand Bracket, Single Pole Limit Switch, and Limit Switch Arm
	1	10107-0035	Chain Tensioner Assembly without Limit Switch
1	1	10244-0035	Sprocket and Bracket Assembly
	1	10244-1000	Sprocket and Bracket Assembly, S/S
2	1	6358-0010	Nut, 5/16-18, RH Thread
3	1	2520-0000	Turnbuckle, Tensioner
4	1	3732-0010	Nut, 5/16-18, LH Thread
5	1	5668-0000	Link, Tensioner
6	1	5959-0007	Arm, Limit Switch, 5" (127mm) Long
7	1	2893-0000	Limit Switch
		2893-0005	Limit Switch, Single Pole
		6269-0000	Limit Switch, Double Pole
		2889-0006	Limit Switch, XPF 4/7
*	1	**	Bolt, Limit Switch Mounting
*	1	**	Lock Washer, Limit Switch Mounting
*	1	**	Washer, Limit Switch Mounting
*	5"	4211-0000	Channel, Unistrut, P3300, 13/16
Unistrut Mounting Hardware:			
*	2	5927-0020	Screw, HHC, 3/8-16x1.25, GR2
*	2	5858-0011	Lock Washer, Std, 3/8
*	2	6296-0011	Washer, Flat, Std, 3/8
*	2	7879-0000	Nut, Twirl, 3/8-16

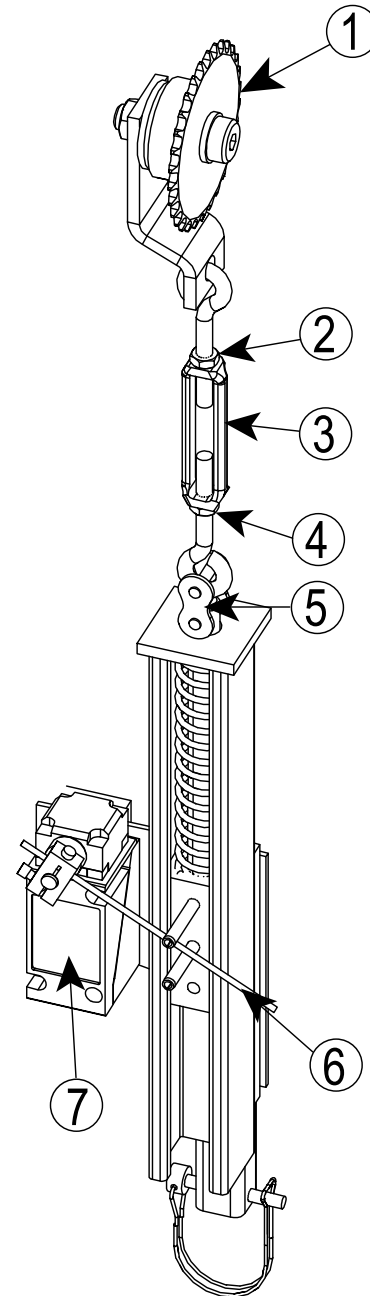

\* Not Shown on Illustration

\*\* Contact PFlow Industries, Inc. Customer Support Department for part number. VRC serial number required.



**Drive Chain  
 Tension Sensor  
 Assembly  
 (located on the  
 Drive Chain  
 Assembly)**

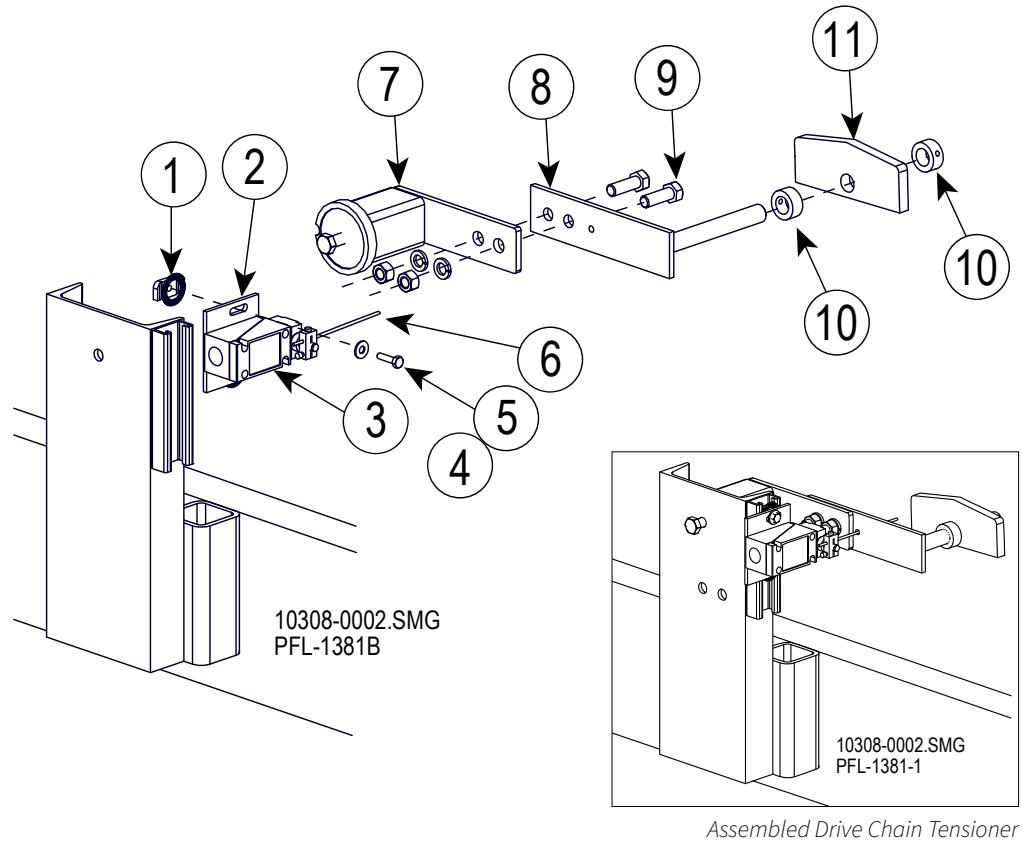

Item	Qty	Part No.	Description
1	2	5834-0000	Nut, Twirl, 1/4-20
2	1	6483-0000	Mounting Plate
3	1	**	Limit Switch
4	2	6029-0016	Screw, HHC 1/4-20 x 1
5	2	6296-0009	Washer, Flat, Std, 1/4
6	1	**	Arm, Adjustable
7	1	5933-0000	Drive Chain Tensioner
8	1	9562-0000	Arm Extension
9	2	6755-0024	Screw, HH 1/2-13 x 1 1/2
	2	5858-0013	Lock Washer, Std, 1/2
	2	6358-0013	Nut, Hex, 1/2-13
10	1	6719-0011	Set Collar 3/4 with Nylock Screw
11	1	7465-0000	Guide, Tension, #100 Drive Chain
	1	6894-0000	Guide, Tension, #120 Drive Chain
	1	J9030-0564	Guide, Tension, #140 Drive Chain
7-11	1	6541-0000	Sensor Assembly, #100 Drive Chain
7-11	1	6541-0001	Sensor Assembly #120 Drive Chain

\*\* Contact PFlow Industries, Inc. Customer Support Department for part number.  
 VRC serial number is required.



**Anderson Interlock**

The interlock is a device used to mechanically prevent the gate from opening. Below is the Anderson interlocks supplied. As a safety device, replacement components are only available as shown below. Some configurations may vary by application.

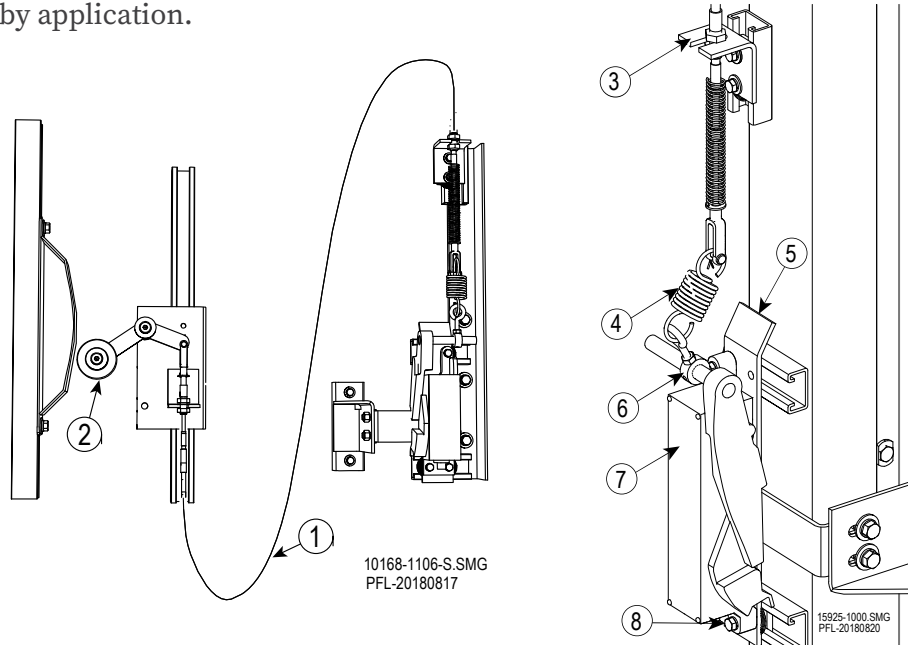

Item	Qty	Part No.	Description
1	1	9292-0120	10' Control Cable Assembly
	1	9292-0180	15' Control Cable Assembly
	1	9292-0300	25' Control Cable Assembly
	1	9292-0360	30' Control Cable Assembly
2	1	9280-0000	Roller Arm Assembly
	1	9284-0040	Wheel, Polyolefin, 2-1/2
3	1	10170-0000	Bracket, Mtg, Control Cable
4	1	**	Extension Spring
5	1	10167-0000	Plate, Interlock, Gate V.A.
6	1	9332-0009	Set Collar, Cable Interlock
	1	3694-0000	Eye Bolt, 1/4-20, 1" Long
	1	6358-0009	Hex Nut, 1/4-20, Plated
7	1	2678-0000	Interlock, Anderson, LH
	1	2678-0001	Interlock, Anderson, RH
	1	2678-4000	Interlock, Anderson, LH, Water Resistant
	1	2678-4001	Interlock, Anderson, RH, Water Resistant
	1	2678-0000-QD	Interlock, Anderson, LH, with Quick Disconnect
	1	2678-0001-QD	Interlock, Anderson, RH, with Quick Disconnect
	1	2678-4000-QD	Interlock, Anderson, LH, Water Resistant, with QD
	1	2678-4001-QD	Interlock, Anderson, RH, Water Resistant, with QD
8	1	6029-0020	Screw, HHC, 1/4-20, 1-1/4"
	1	5858-0009	Lock Washer, Std, 1/4
	1	5834-0001	Nut, 1/4-20, with Spring

\*\* Contact PFlow Industries, Inc. Customer Support Department for part number. VRC serial number required.

**PFlintlock Interlock**

Item	Qty	Part No.	Description
1	1	9292-0120	10' Control Cable Assembly
	1	9292-0180	15' Control Cable Assembly
	1	9292-0300	25' Control Cable Assembly
	1	9292-0360	30' Control Cable Assembly
2	1	9280-0000	Roller Arm Assembly
	1	9284-0040	Wheel, Polyolefin, 2-1/2
3	1	10170-0000	Bracket, Mtg, Control Cable
4	1	**	Extension Spring
5	1	9332-0009	Set Collar, Cable Interlock
	1	3694-0000	Eye Bolt, 1/4-20, 1" Long
	1	6358-0009	Hex Nut, 1/4-20, Plated
6	1	11947-0001	Plate, Interlock, PFlintlock
7	1	19080-0000	Interlock, PFlintlock, 2 Contact, LH, ETL
	1	19080-0001	Interlock, PFlintlock, 2 Contact, RH, ETL
	1	19080-0002	Interlock, PFlintlock, 1 Contact, LH, ETL
	1	19080-0003	Interlock, PFlintlock, 1 Contact, RH, ETL
8	3	6029-0016	Screw, HHC, 1/4-20, 1.0, GR5
	3	5858-0009	Lock Washer, Std, 1/4
	3	7768-0009	Washer, Flat, 1/4, SAE
	3	5834-0000	Nut, Twirl, 1/4-20

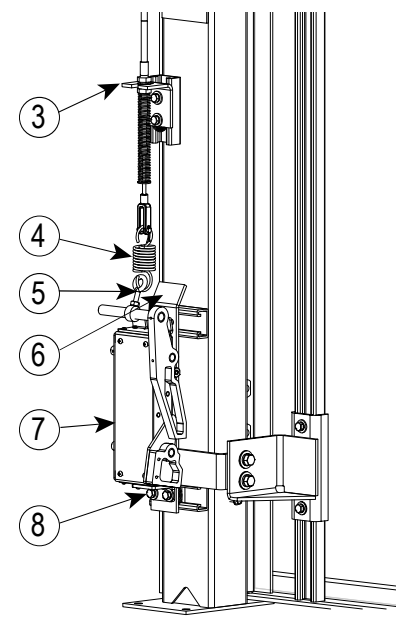
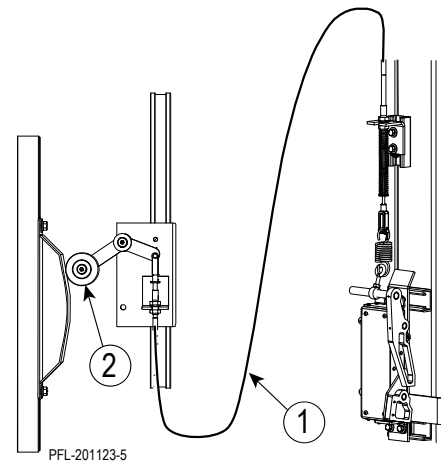

\*\* Contact PFlow Industries, Inc. Customer Support Department for part number. VRC serial number required.

**GAL Interlock**

Item	Qty	Part No.	Description
1	1	13660-0000	Interlock, GAL, RH
	1	13661-0000	Interlock, GAL, LH
2	1	8078-0013	Keeper

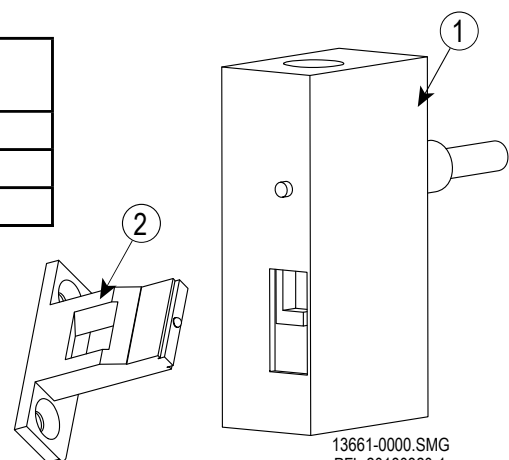

13661-0000.SMG  
 PFL-20180820-1



**Gate Status Switches**

A gate status switch is supplied when the contact are not being used. If required, it will be mounted to the gate post or header. Normally the GAL and Anderson interlocks do not use this switch. Specific order requirements may differ.

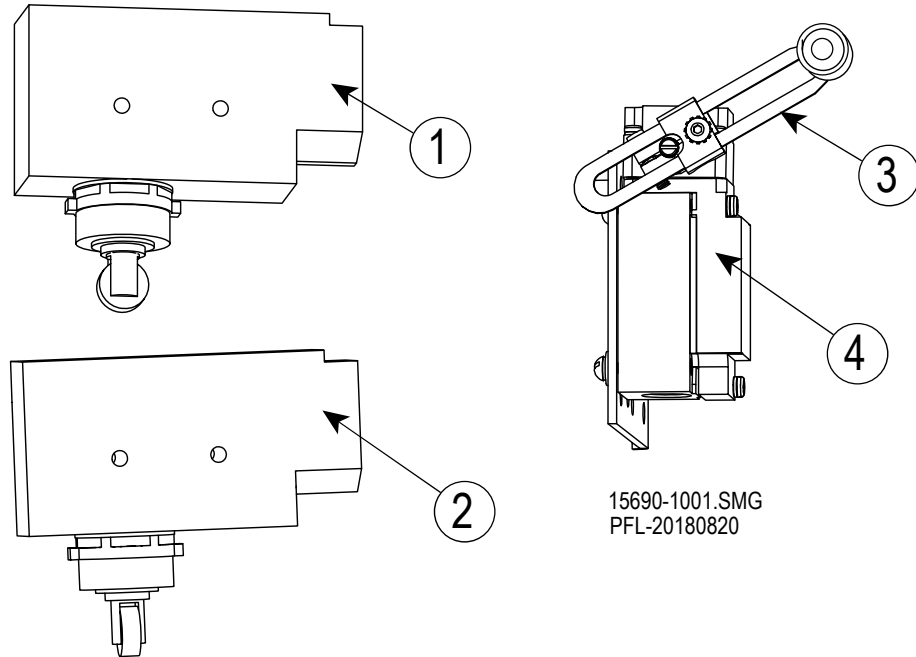

Item	Qty	Part No.	Description
1	1	6220-0000	Roller Plunger, Parallel
2	1	6216-0000	Roller Plunger, Perpendicular
3	1	2891-0000	Adjustable Roller Arm
4	1	2893-0000	Switch



**Safety Cam Assembly**

Columns are produced with three (3) different web flange thicknesses. Be aware that epoxy paint and galvanized coatings add to that thickness:

- 15# = .260" (+.005" coating)
- 20# = .360" (+.005" coating)
- 25# = .460" (+.005" coating)

<b>15# Columns</b>	<b>Right-hand</b>	<b>17550-0000</b>
<b>15# Columns</b>	<b>Left-hand</b>	<b>17550-1000</b>
<b>20# Columns</b>	<b>Right-hand</b>	<b>17550-0001</b>
<b>20# Columns</b>	<b>Left-hand</b>	<b>17550-1001</b>
<b>25# Columns</b>	<b>Right-hand</b>	<b>17550-0002</b>
<b>25# Columns</b>	<b>Left-hand</b>	<b>17550-1002</b>
<b>25# Columns - HT</b>	<b>Right-hand</b>	<b>17550-0012</b>
<b>25# Columns - HT</b>	<b>Left-hand</b>	<b>17550-1012</b>

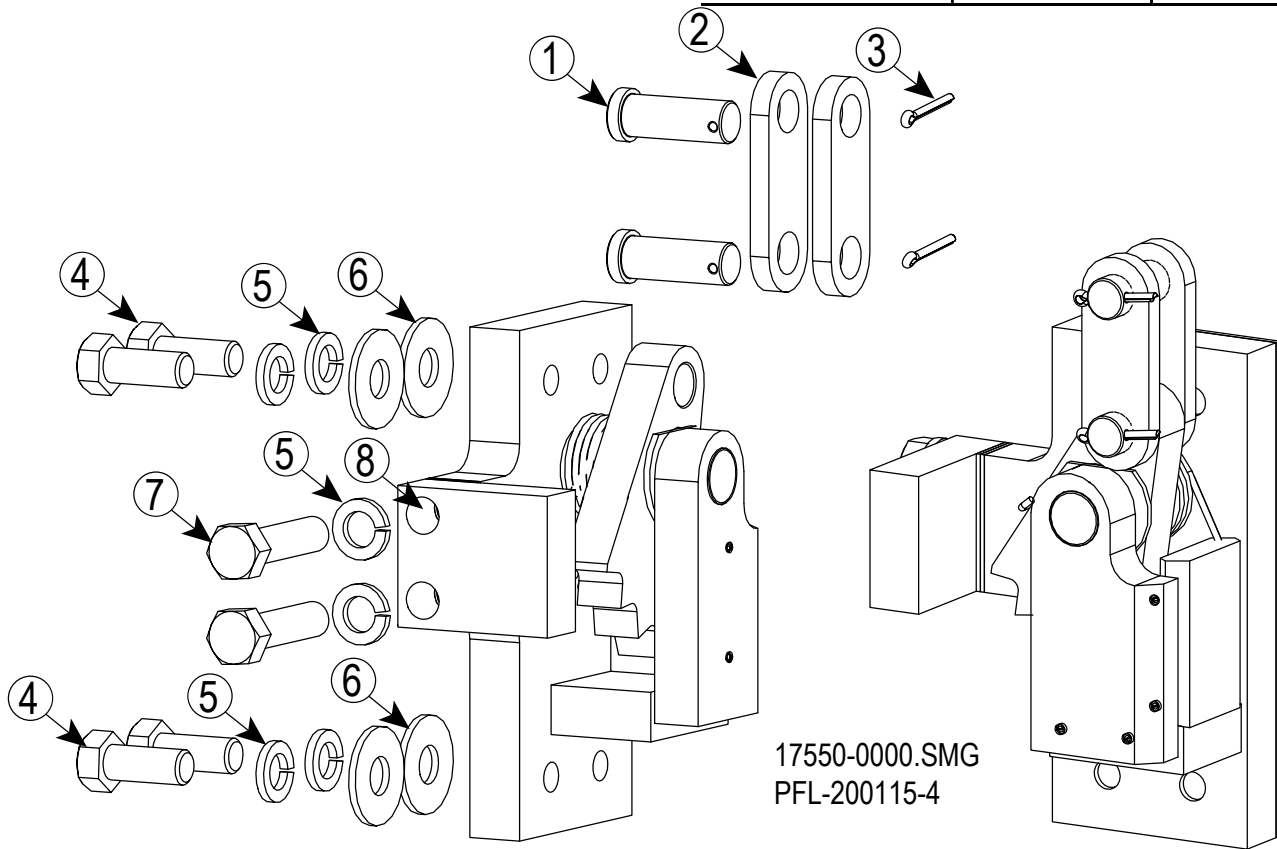

Item	Qty	Part No.	Description
1	2	8742-0032	Pin, Clevis, 15# Column
	2	2521-0000	Pin, Clevis, 20# & 25# Column
2	2	6187-0001	Link, Safety Cam, Treated
3	2	2522-0000	Pin, Cotter, 5/32 X 1 1/4
4	4	7278-0024	Screw, HHC, 5/8-11 X 1.5, Gr5

Item	Qty	Part No.	Description
5	6	5858-0015	Lock Washer, Std, 5/8
6	4	6296-0015	Washer, Std, Flat, 5/8
7	2	2198-0040	Screw, HHC, 5/8-11 X 2.25, Gr8
8	1	2754-0000	Shoe, Safety Cam
*	1	2767-0000	Spacer, Safety Cam Shoe, .08 (20# Columns)
	2	2767-0000	Spacer, Safety Cam Shoe, .08 (25# Columns)

\* Not shown on illustration



**Guide Roller Block Assembly - 17840-0000**

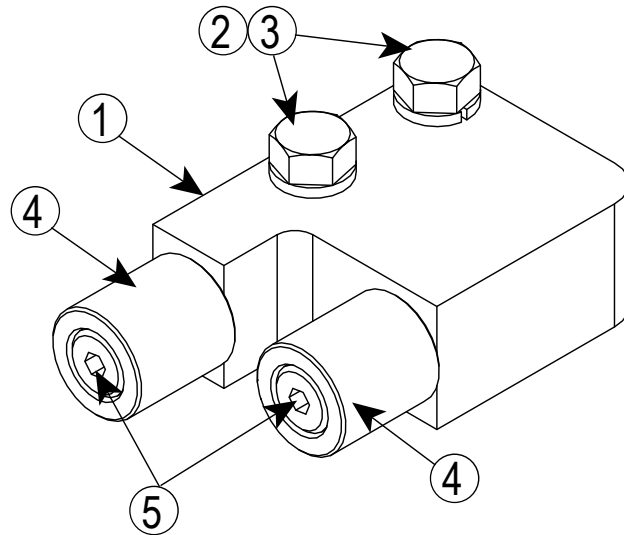

Item	Qty	Part No.	Description
1	1	17838-0000	Block, Guide Roller
2	2	9237-0040	Bolt, HHC, 1/2-13 x 2.5, GR5
3	2	5858-0013	Lock Washer, STD, 1/2
4	2	17539-0000	Roller, Guide, 1.25 OD
5	2	2503-0028	Bolt, Shoulder, 1/2 x 1 3/4

**Twin Roller Guide Wheelblock Assembly**

**RH - 17544-0000**

**Nyloil Wheels (green)**

**LH - 17544-1000**

*Note: Apply moly coat grease to inside diameter of wheel prior to inserting pin.*

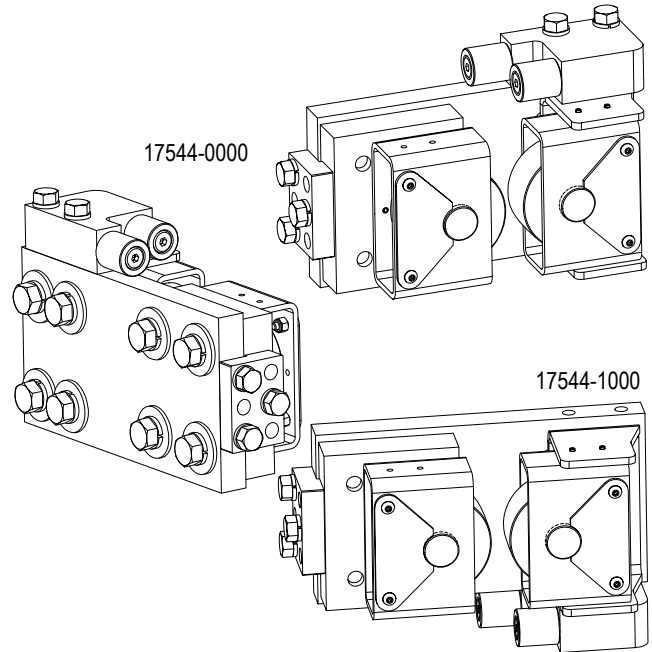
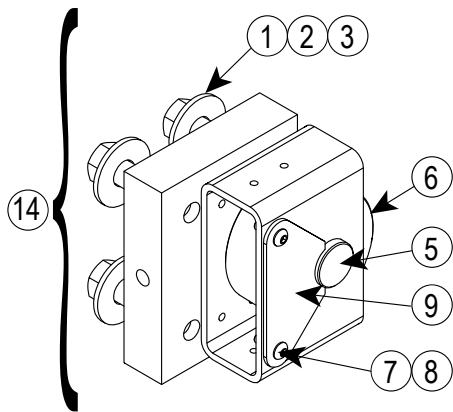
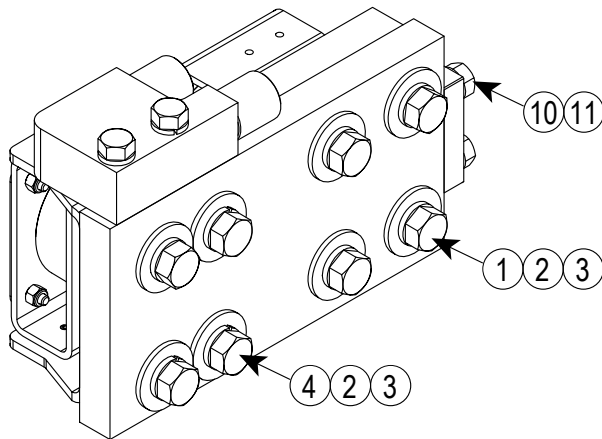
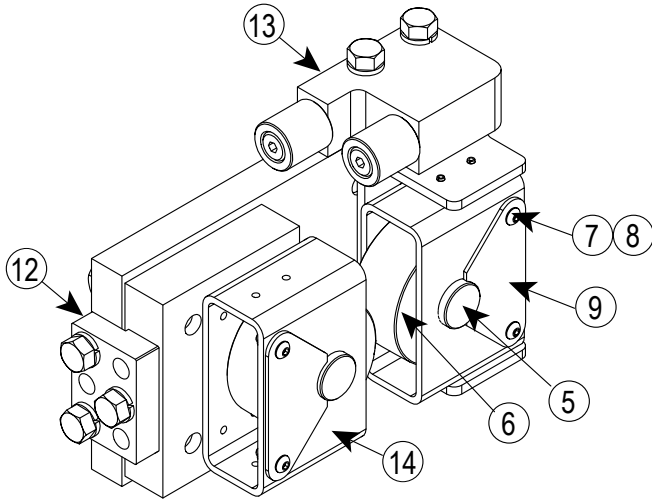

Item	Qty	Part No.	Description
1	4	6758-0036	Screw, HHC, 5/8-11 x 2.25, GR5
2	8	5858-0015	Lock Washer, Std, 5/8
3	8	6296-0015	Washer, Std, Flat, 5/8
4	4	7278-0024	Screw, HHC, 5/8-11 X 1.5, GR5
5	2	17546-0000	Pin, 30mm
6	2	17548-0000	Wheel, Nyloil, 3.5 x 1.5
7	4	2888-0012	Screw, BHSC, 1/4-20 x 3/4
8	4	6708-0009	Nut, Lock, Nylon, 1/4-20
9	2	17545-0000	Plate, Retainer
10	3	9237-0024	Screw, HHC, 1/2-13 x 1.5, GR5
11	3	5858-0013	Lock Washer, Std, 1/2
12	1	17561-0000	Bar Clamp
13	1	17840-0000	Guide Roller Block Assembly
14	1	17543-0000	Nyloil Wheel Assembly





**Twin Roller Guide Wheelblock Assembly RH - 17544-0010 Polyurethane Wheels (red)**  
**LH - 17544-1010**

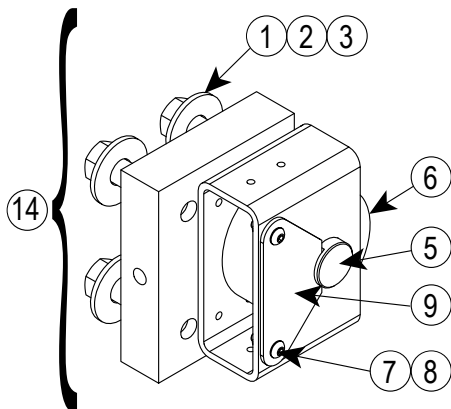
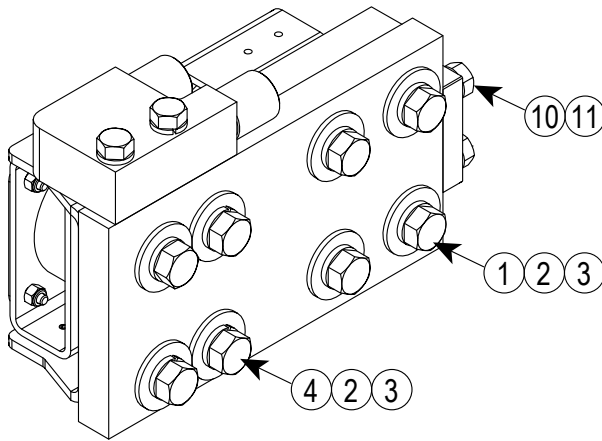
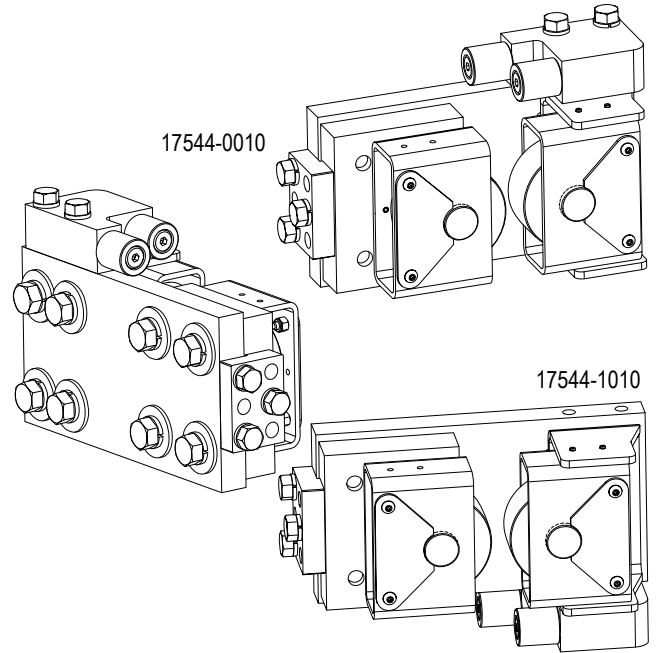
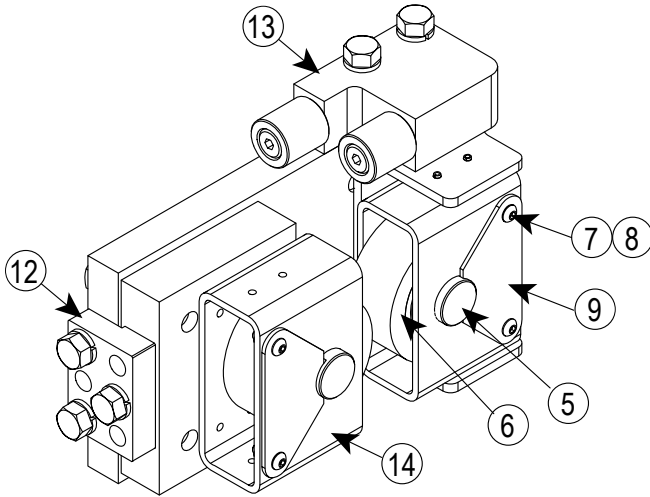

Item	Qty	Part No.	Description
1	4	6758-0036	Screw, HHC, 5/8-11 x 2.25, GR5
2	8	5858-0015	Lock Washer, Std, 5/8
3	8	6296-0015	Washer, Std, Flat, 5/8
4	4	7278-0024	Screw, HHC, 5/8-11 X 1.5, GR5
5	2	17546-0000	Pin, 30mm
6	2	17376-0000	Wheel, Polyurethane, 3.5 x 1.5
7	4	2888-0012	Screw, BHSC, 1/4-20 x 3/4
8	4	6708-0009	Nut, Lock, Nylon, 1/4-20
9	2	17545-0000	Plate, Retainer
10	3	9237-0024	Screw, HHC, 1/2-13 x 1.5, GR5
11	3	5858-0013	Lock Washer, Std, 1/2
12	1	17561-0000	Bar Clamp
13	1	17840-0000	Guide Roller Block Assembly
14	1	17543-0100	Polyurethane Wheel Assembly

**Single Roller Guide Wheelblock Assembly**    **RH Upper - 17541-0200**  
**LH Upper - 17541-1200**  
**RH Lower - 17542-0200**  
**LH Lower - 17542-1200**

**Steel Wheels**

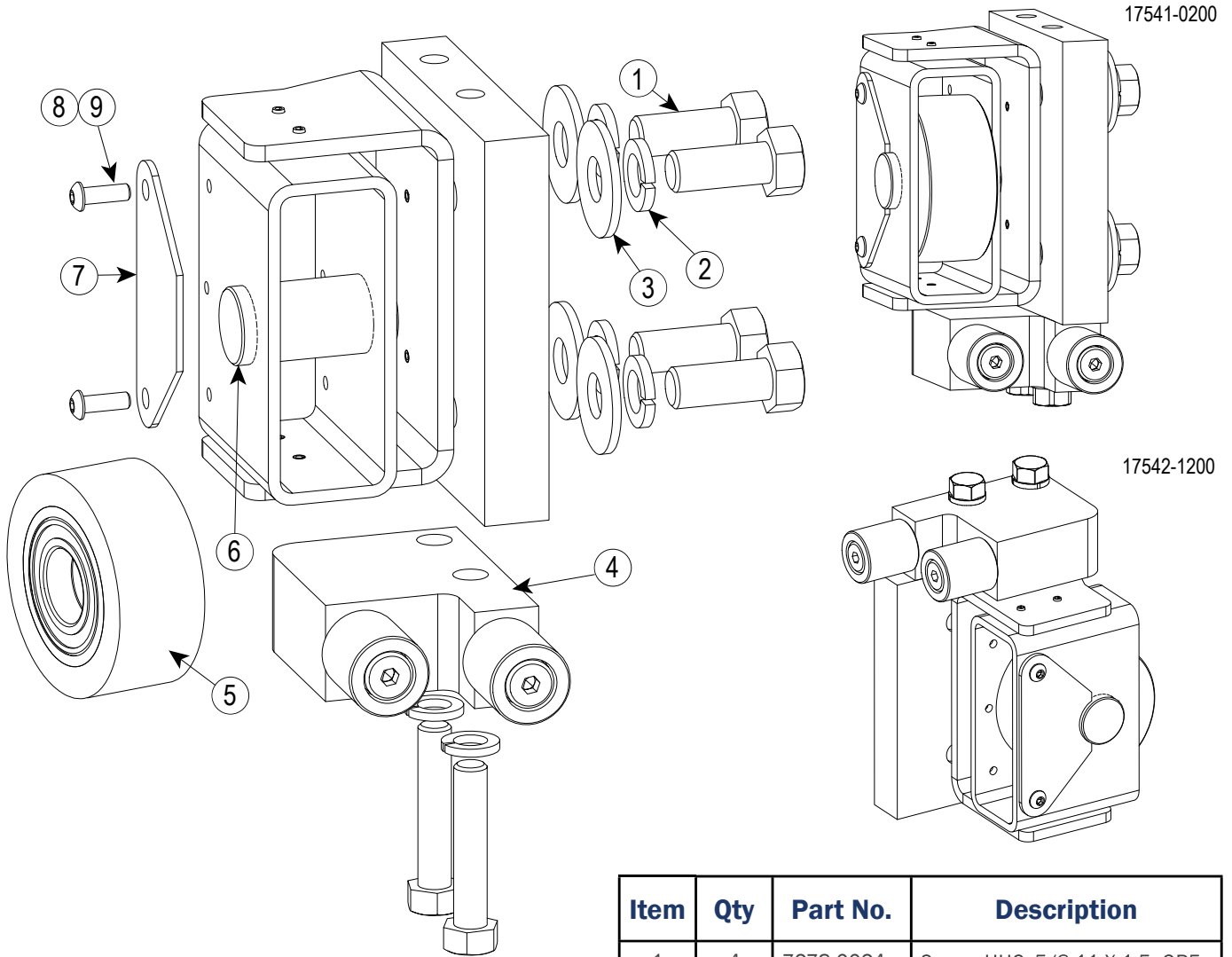

Item	Qty	Part No.	Description
1	4	7278-0024	Screw, HHC, 5/8-11 X 1.5, GR5
2	4	5858-0015	Lock Washer, Std, 5/8
3	4	6296-0015	Washer, Std, Flat, 5/8
4	1	17840-0000	Guide Roller Block Assembly
5	1	17381-0000	Wheel, Steel, 3.5 x 1.5
6	1	17546-0000	Pin, 30mm
7	1	17545-0000	Plate, Retainer
8	2	2888-0012	Screw, BHSC, 1/4-20 x 3/4
9	2	6708-0009	Nut, Lock, Nylon, 1/4-20



### Environment

All components should be **stored indoors**. The area of storage should be kept at a constant temperature above 55° F (13° C) and relative humidity of approximately 40%, free from heavy dust and contaminants.

#### NOTICE

Outdoor storage is **not** recommended. Our warranty policy does not cover damage as a result of improper storage.

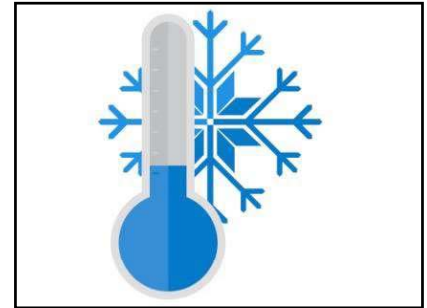

Avoid Cold Temperatures Figure 18-1

### Stacking

Except for placing the parts container (crate) and bracing on the empty carriage, stacking of the various gate components is strictly forbidden. Enclosure and gate panels will warp. Objects stacked on top of the columns, drivebase assembly and/or hydraulic cylinders may cause severe damage. See Figure 18-2.

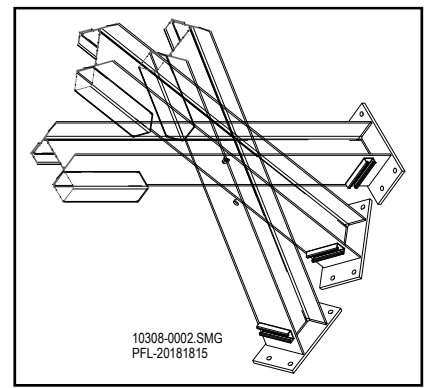

Do Not Stack Components Figure 18-2

### Long Term Storage

Storage for more than two months after shipment, will require that the following maintenance procedures be performed every sixty days from date of shipment:

1. If **roller chains** are stored for an extended period of time or in a corrosive environment, they must be dipped or stored in a non-detergent oil to retain their original condition.
2. Lightly coat the **sprockets** with a non-detergent oil to prevent corrosion.
3. Lubricate the **safety cams** on the exposed **safety cam assemblies** with a non-detergent oil and rotate to make sure the safety cams move freely. See Figure 18-3.
4. Elevate the **drivebase assemblies** off the ground and cover with a tarp. Allow adequate ventilation to minimize condensation. Protect all exposed or unpainted shaft and flange surfaces with an anti-corrosion agent or grease. Store in a location free from shock and vibration, to avoid false brinelling of the bearing elements and raceways.

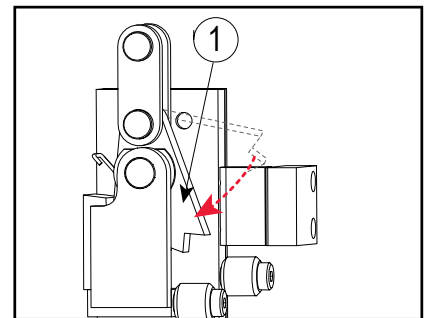

Lubricate and Rotate Safety Cam  
Figure 18-3

Long Term Storage  
(continued)

 **DANGER**



High Voltage! Employees servicing or maintaining VRCs may be exposed to death or serious personal injury if hazardous energy is not properly controlled. Follow your facilities, national, or local safety lockout/tagout (LOTO) procedures anytime maintenance or service is being performed on any electrical box or component. Only qualified and trained service technicians are to apply power to the motor.

 **CAUTION**

The incoming voltage source must match the voltage identified on the rating tag. The rating tag provides essential technical information required for any installation, maintenance, or repairs. Do not remove, damage, or modify the rating tag.

**NOTICE**

A qualified person is defined as a person who, by possession of a recognized degree or certificate of professional standing, or by extensive knowledge, training, and experience, has successfully demonstrated his/her ability to solve problems relating to the subject matter and work.

5. Rotate the drivebase shaft. **Apply power** to the motor/brake with the correct voltage and correct brake wiring configuration with the vent plug installed in the reducer. This will rotate the drive shaft and cycle the brake once. **Manually cycle the brake** several times using the lever on the side of the motor. After rotating with temporary power, remove the vent plug and install the original plug to prevent contamination of the reducer oil. Before initial use, drain and replace the reducer oil.
6. Apply lithium-type grease to the **pillow block and bearings**. Wrap or trap the pillow blocks to avoid exposure to contaminants if needed.
7. Plug the **electrical component** inlets to prevent moisture and other contaminants from entering them. Store in a dry, temperature controlled location to prevent corrosion. Place silica gel desiccant inside the control enclosure. Inspect the inside of the control enclosure for any moisture build up. See Figure 18-4.
8. Make sure the **parts crate** remains sealed and dry.



Place Inside Control Enclosure  
Figure 18-4

Storage for Longer  
than Six Months

For units stored longer than six months, it is recommended that you contact the PFlow Industries, Inc. Customer Support Department for additional information that may be available prior to starting up your unit.

Equipment Manuals

The VRC installation manual, electrical, and owner's manuals are located in the parts container (crate). Do not open the parts container (crate). If the manuals are required, contact the PFlow Industries, Inc. Customer Support Department for an electronic copy (.pdf).

**Before You Begin**

*Read this entire manual.*

**Purpose**

The PFlow Industries, Inc. Vertical Reciprocating Conveyor (VRC) is designed for the movement of materials only, up to the VRC's rated capacity, from one level to the next. Passengers are not allowed. The placement of capacity labels, and safety warnings are the installer's responsibility. Make sure the warning labels are placed on each gate and each push-button station.

PFlow Industries, Inc. supplies the appropriate signage in a manila envelope in the parts crate with the original shipment. Contact PFlow Industries, Inc. Customer Support Department for signage if another language is needed.

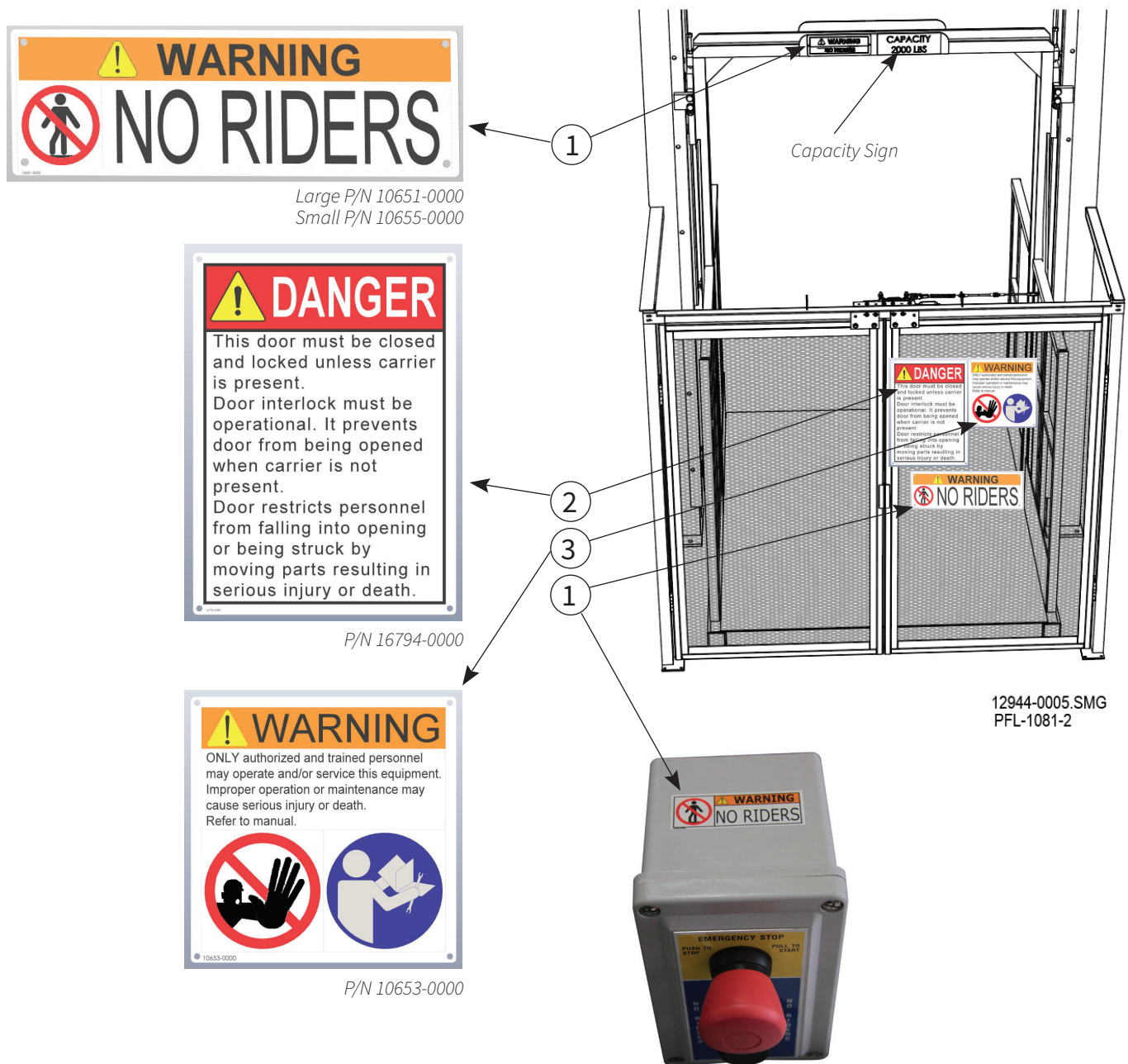

## Section 19 | Signage Locations



**MATERIAL HANDLING SOLUTIONS**

[www.pflow.com](http://www.pflow.com)  
P 414 352 9000  
F 414 352 9002  
6720 N. Teutonia Ave.  
Milwaukee, WI 53209



# Installation Questionnaire



**MATERIAL HANDLING SOLUTIONS**

www.pflow.com  
 P 414 352 9000  
 F 414 352 9002  
 6720 N. Teutonia Ave.  
 Milwaukee, WI 53209

## Thank You

PFlow Industries, Inc. would like to thank you for the opportunity to serve you. Your business is appreciated. Please help us to ensure that your expectations are met by taking a few minutes to tell us about the equipment and service that you have received. Complete the Installation Questionnaire and Acceptance Certificate. Return both forms to PFlow Industries, Inc. via e-mail to [csd@pflow.com](mailto:csd@pflow.com). Additional space for comments is available on the next page.

Yes ✓ No ✓

## Product Perception

Was the equipment shipment complete as expected?		
What items were missing, if any?		

Was the equipment in good condition?		
Describe the equipment damage or concerns with the workmanship, if any.		

Did the equipment match the General Arrangement (GA) drawing?		
Was the equipment dimensionally correct with form, fit, and function?		
Describe any problem areas in detail.		

## Electrical Installation

Was the electrical field wiring completed as required?		
Were there any issues with the electrical components?		
After the electrical installation was completed, was it necessary to return for final adjustments, testing, and training?		
Were you made aware of any electrical problems?		
Describe any "No" answers in detail.		

## Testing

Was the equipment tested at full load capacity?		
Were all gates tested to ensure proper operation and interlock operation?		

PFlow Serial Number	Customer/User	Date
Questionnaire Completed by	E-mail Address	
Company	Phone Number	

# Installation Questionnaire



**MATERIAL HANDLING SOLUTIONS**

[www.pflow.com](http://www.pflow.com)  
P 414 352 9000  
F 414 352 9002  
6720 N. Teutonia Ave.  
Milwaukee, WI 53209





# Acceptance Certification



**MATERIAL HANDLING SOLUTIONS**

www.pflow.com  
 P 414 352 9000  
 F 414 352 9002  
 6720 N. Teutonia Ave.  
 Milwaukee, WI 53209

## Acceptance

We, the Customer, accept the equipment listed below as being properly installed, tested, and performing to our satisfaction. This form covers both the mechanical and the electrical installation of the equipment. This acceptance in no way releases either PFlow Industries, Inc. or the installing contractor(s) of any warranty obligations. If there are any exceptions or unresolved items, please include detailed information.

PFlow Serial Number:	Model Number:	<input type="checkbox"/> B	<input type="checkbox"/> D	<input type="checkbox"/> DB	<input type="checkbox"/> F	<input type="checkbox"/> M	<input type="checkbox"/> 21	Other _____
Job Name:								
Site Street Address:								
Site Mailing Address:								
Site City:						State:		Zip Code:
Customer Contact Name:						Contact Title:		
Customer Contact Phone: ( )						Ext		E-Mail:

<b>Tests Performed</b>	Load Capacity:				Start-up Date:
	Load Test:	<input type="checkbox"/> Yes	<input type="checkbox"/> No	at ____ % of lift capacity	Customer Initials:
	Operation Test:	<input type="checkbox"/> Yes	<input type="checkbox"/> No		Comments:
	Gate/Interlock Operation:	<input type="checkbox"/> Yes	<input type="checkbox"/> No	<input type="checkbox"/> Not Applicable	
	Other Test:				
	Other Test:				

Personnel Instructed on the Operation and Preventive Maintenance:	
Name:	Company:
Name:	Company:

Accepted by:	Acceptance Date:
Name/Phone:	PFlow Rep Present:
Title:	Name:
Company:	Company:

Please return a copy of this form to the PFlow Industries, Inc. Customer Support Department at [csd@pflow.com](mailto:csd@pflow.com).

# Acceptance Certification



**MATERIAL HANDLING SOLUTIONS**

[www.pflow.com](http://www.pflow.com)  
P 414 352 9000  
F 414 352 9002  
6720 N. Teutonia Ave.  
Milwaukee, WI 53209

