



D Series | Hydraulic VRC

Installation Manual

Important:



**Read this entire manual.
Important safety information
is included.**

**Before starting the installation,
verify the job site dimensions and the
dimensions of the delivered materials
against the PFlow Industries, Inc.
General Arrangement (GA) drawing.**

The illustrations depicted in this manual
are not to scale or detail. The illustrations
are for reference only.





Description		Section Page
1. Contact Information	15705-0011	1 1
2. General Information	15710-0004	2 1
Introduction		2 1
General Overview		2 1
Code Requirements		2 1
Parts		2 1
Service		2 1
Feedback		2 1
3. Warranty Information	15710-0014	3 1
Parts and Labor		3 1
Definitions		3 1
Warranty		3 1
Exclusions		3 1
Obligation		3 1
Liability		3 2
Warranty Procedures		3 2
Pre-Authorization		3 2
Invoices		3 2
4. Important Safety Information	15702-0004	4 1
Read the Entire Manual		4 1
Intended Purpose		4 1
Safety Alert Symbols		4 1
Danger Statements		4 2
Warning Statements		4 2
Hydraulic Safety Precautions		4 4
Caution Statements		4 5
Electrical Safety Precautions		4 6
De-energize the Circuit		4 6
Electrical Safety Precautions		4 7
Working on Energized Circuits		4 7
Notes for the Installation Electrician		4 7
Entrance Below a Raised Carriage Deck	15709-0083	4 9
5. Glossary	15710-0018	5 1
Unique Descriptions and Names		5 1
Gate Types		5 8
Identifying Call Outs		5 9



Description		Section Page
6. Equipment Arrival and Unpacking	15710-0006	6 1
Arrival		6 1
Inspection		6 1
Transportation Damage and Claims		6 1
Shipping Photograph Examples		6 2
Shipping Packet		6 3
Return Materials Authorization (RMA)		6 3
Warranty Work		6 3
Recommended Tools		6 4
7. Pre-Installation Responsibilities	15710-0008	7 1
End User Responsibilities		7 1
End User and/or Mechanical and/or Electrical Installer Responsibilities		7 1
Mechanical Installer Responsibilities		7 2
Electrical Installer Responsibilities		7 2
8. Job Site General Arrangement (GA) Review	15710-0011	8 1
9. Frequently Asked Questions	15710-0011	9 1
10. Sequence of Installation		10 1
11. Placement	15702-0011	11 1
Verify Job Site Dimensions and Carriage Orientation		11 1
Mark Alignment		11 1
Position the Carriage		11 2
12. Backframe Set-Up	15702-0005	12 1
Purpose		12 1
Remove the Back Panel		12 1
Review the GA Drawing for Backframe Placement		12 1
Spliced Backframe Guidelines		12 2
Assemble the Spliced Backframe		12 2
Align the Spliced Backframe		12 3
Tack Weld the Spliced Backframe		12 4
Spliced Backframe Finish Welding Details		12 4
Raise and Secure the Backframe		12 5
Prepare the Wheelblocks		12 6
Insert the Wheelblocks		12 5
Attach the Lower Wheelblocks		12 7
Attach the Upper Wheelblocks		12 8
Review the Backframe for Plumb		12 9
Brace the Backframe		12 10
Install the Hydraulic Cylinder		12 11



Description		Section Page
13. Bracing	15702-0013	13 1
Required Anchoring and Bracing Guidelines		13 1
Side to Side and Front to Back Bracing		13 2
Bracing Supplies		13 2
Anchoring Guidelines		13 3
Bracing Guidelines		13 4
16. Gate Identification	15709-0158	16 1
Identify Components		16 1
Sliding Gate		16 2
Swing Gate		16 3
Vertical Acting Gate		16 4
Installation Instruction List		16 5
17. Gate Cable Interlock	15709-0029	17 1
Important Safety Information		17 1
Purpose		17 2
General Description		17 4
Carriage Cam		17 4
Column Mounted Roller Assembly		17 4
Control Cable		17 4
Gate Cable Interlock Assembly		17 4
Peelle Terms		17 5
Important Safety Information		17 6
Straddle Placement		17 7
Cantilever Placement		17 7
Adjust the Interlock Assembly		17 8
Adjust the Cam and Cable		17 8
Position the Roller Arm on the VRC Column		17 9
Wire the Single Contact PFIinterlock Interlock		17 11
Wire the Dual Contact PFIinterlock Interlock		17 12
Wire the Electrical Switches		17 13
18. Enclosure Panels	15709-0038	18 1
Full Height Enclosures		18 1
Inventory Enclosure Panels		18 2
Assemble and Install Enclosure Panels		18 2
19. Signage Locations	15709-0035	19 1
20. Landing Platform or Ramp	15709-0004	20 1
Install the Gate Post Extensions		20 1
Install the Landing Platform		20 1
Install the Ramp		20 1



Description		Section Page
21. Hydraulic Installation and Start-Up Procedures	15702-0010	21 1
Hydraulic Safety Precautions		21 1
General Hydraulic Information		21 2
General Hydraulic Precautions		21 2
Install the Hydraulic Pump		21 3
Review the GA Drawing for Placement		21 3
Placement Considerations		21 3
Clean the Fittings and Hoses		21 4
Attach the Fittings and Hose to the Cylinder		21 4
Attach the Fitting and Hose to the Hydraulic Pump		21 5
Thread Sizes		21 5
Install the Breather Cap		21 6
Start-Up Procedures		21 7
Confirm E-stop Safety Operation		21 7
Confirm Motor Rotation		21 7
Make Sure There are No Leaks		21 7
Confirm that the Pump Motor Shuts Off		21 8
Adjust the Pressure Relief Valve (if needed)		21 8
Adjust the Pressure Switch (if needed)		21 8
Confirm Carriage Stops are Level with the Floor		21 9
Confirm Carriage Travel Speeds		21 9
Adjust the Flow Control Valve (if needed)		21 9
Confirm Gate Safety Operation		21 9
22. Adjust Motor Overload Sensor (MOL)	15702-0022	22 1
The Purpose of the Motor Overload Sensor (MOL)		22 1
Locate the Full Load Amperage (F.L.A.) Value		
Test and Calibrate the MOL		22 1
23. Installation Completion Checklist	15702-0023	23 1
24. Installation Questionnaire	15708-1500	24 1
25. Acceptance Certification - VRC	15710-0017-VRC	25 1

Table of Contents



MATERIAL HANDLING SOLUTIONS

www.pflow.com
P 414 352 9000
F 414 352 9002
6720 N. Teutonia Ave.
Milwaukee, WI 53209





PFlow Industries, Inc.
6720 N. Teutonia Avenue
Milwaukee, Wisconsin 53209



Office
Phone: 414-352-9000
Fax: 414-352-9002



Customer Support Department
e-mail: csd@pflow.com



Sales
e-mail: sales@pflow.com

For a list of contact personnel visit the PFlow Industries, Inc. website at:
<https://www.pflow.com/contact>

Documentation

PFlow Industries, Inc. reserves the right to make changes or improvements to the standard model line at any time. PFlow Industries, Inc. reserves the right to make changes to subsequent editions of the manual without prior notice to holders of this edition.

Copyright Notice

© Copyright February 2024 by PFlow Industries, Inc.

All rights reserved.

No part of this manual may be reproduced or used in any form without expressed written permission from PFlow Industries, Inc.

This publication may be photocopied by the original purchaser. Any other type of reproduction is prohibited without express written permission from PFlow Industries, Inc.

Trademarks

All trademarks referenced in this manual are the property of their respective owners.

System Modifications/Disclaimer

Mechanical or electrical modifications performed on the equipment not approved by PFlow Industries, Inc. may void any warranty and/or service agreements. Please contact the PFlow Customer Support Department for assistance with service modifications.

Training

Training is available upon request from the Customer Support Department. Half-Day, Full-Day, and Two-Day sessions are customized to fit specific needs - either for a single equipment type or for the entire product line.

On-site Supervision

On-site supervision services are available from the Field Service Department. Contact our Field Service Manager for more details.

Source Language

This manual is written in American English.

Section 1 | Contact Information



MATERIAL HANDLING SOLUTIONS

www.pflow.com
P 414 352 9000
F 414 352 9002
6720 N. Teutonia Ave.
Milwaukee, WI 53209





Introduction	This manual provides information about the PFlow Industries, Inc. custom designed Vertical Reciprocating Conveyor (VRC). As the nations' leading manufacturer of vertical material handling equipment, PFlow Industries, Inc. is confident that this new VRC will provide many years of reliable service.
General Overview	The VRC provides a safe and simple means of moving material from one level to another. The simplicity of design and few moving components ensure a trouble-free, long life, with low maintenance and little downtime.
Code Requirements	<i>This VRC is designed for the movement of materials only, up to the VRC's rated capacity, from one level to the next. Do not allow anyone to ride on the VRC.</i> VRCs are not elevators, and are specifically excluded within the scope of the ASME A17.1 Safety Code for Elevators and Escalators. VRCs are included in ASME B20.1 Safety Standard for Conveyors and Related Equipment, which is incorporated by reference into OSHA 29 CFR 1910. A copy of the ASME B20.1 standard can be purchased at www.asme.org and other sources. PFlow Industries, Inc. recommends that this standard be referenced for appropriate installation, maintenance, inspection, and operation in relation to hazards. All electrical designs and components are in accordance with National Electric Code (NEC) requirements. Local codes may require initial inspection of the installation and periodic inspection and testing of the unit. Contact PFlow Industries, Inc. for more information in the event an inspection is required.
NOTE	<i>The information and illustrations in this manual are intended only as an aid to understanding the VRCs general installation. The information and illustrations do not cover every possible contingency or circumstance regarding nonstandard options or site conditions.</i>
Parts	If there is a problem, call PFlow Industries, Inc. at (414) 352-9000, during normal business hours, 8:30 a.m. to 5:00 p.m. central standard time, Monday through Friday. Outside of those hours, see the PFlow Industries, Inc. Contact Information page for additional information. Use the model number and serial number or the PFlow Industries, Inc. General Arrangement (GA) drawing number for the lift in all correspondence. Equipment damage resulting from modification in any manner from the original model, including the substitution of parts other than factory authorized parts, will void the warranty. Furthermore, PFlow Industries, Inc. will not be liable for any loss, injury, or damage to persons or property, nor for direct, indirect, or consequential damage of any kind resulting from modified or substitution of parts other than factory authorized parts of said material or equipment. PFlow Industries, Inc. maintains a complete stock of, or has access to, all replacement components. Detailed records of all equipment sold are kept. If a component is damaged in shipment, is defective or missing, contact PFlow Industries immediately.
Service	The PFlow Industries, Inc. Customer Support Department will assist maintenance and service personnel with any questions or problems regarding the equipment or installation.
Feedback	Your feedback is important. Please help PFlow Industries, Inc. understand if the equipment has met your expectations. Please complete the questionnaire in this manual. The questionnaire will help us address any comments and/or concerns.

Section 2 | General Information



MATERIAL HANDLING SOLUTIONS

www.pflow.com
P 414 352 9000
F 414 352 9002
6720 N. Teutonia Ave.
Milwaukee, WI 53209





Parts and Labor

Parts:		Labor:	
Structure	Lifetime	Structure	Lifetime
Manufactured Components	1 Year	Manufactured Components	1 Year
Purchased Components	1 Year	Purchased Components	Supplier
Gates and Enclosures	90 Days	Gates and Enclosures	90 Days

Definitions

- Structure is defined as columns, carriage, and pre-fabricated bracing (excluding carriage side guards).
- Manufactured components are defined as those components manufactured by PFlow Industries, Inc.
- Purchased components are those components that are used as supplied by vendors and covered by the Supplier’s labor warranty.

Warranty

PFlow Industries, Inc. expressly warrants to the original purchaser that this product will be free from defects in material and workmanship under normal, intended use. The warranty period begins 60 days after shipment.

Exclusions

This warranty does not apply to:

1. Equipment or components damaged or broken in transit or shipping.
2. Replacement of wear parts.
3. Equipment failures caused by abuse, misuse, exceeding recommended capacities, impact with other objects, negligence, improper installation, unskilled use, unskilled maintenance, inadequate maintenance, or incorrect adjustments.
4. Exposure to a corrosive or abrasive environment or exterior elements unless specifically built for that environment.
5. Equipment that has been repaired, altered or modified in any manner outside of the manufacturing facility, substitution of parts other than factory authorized parts, removal of any parts, or addition of any parts without prior written permission by PFlow Industries, Inc.
6. Any losses or damages resulting from loss of data, loss of revenue or profits, loss of products, incidental or consequential damages, delays, or expenses incurred by failure of said part or parts even if advised of the possibility thereof.
7. Lost time and/or additional trips for missing or damaged components.
8. Expedited freight charges.

Obligation

The obligation for PFlow Industries, Inc. is limited to only the replacement or repair of defective components that received prior authorization. This is the owner’s sole remedy.

PFlow Industries, Inc. will bear normal labor charges performed by an authorized PFlow Industries, Inc. service agent during standard business hours, excluding overtime, holiday rates, or any additional fees.

This warranty applies to all models and no person except an officer of PFlow Industries, Inc. is authorized to modify this warranty or to incur on behalf of PFlow Industries, Inc. any other obligation or liability in connection with PFlow Industries, Inc. equipment.



Liability

PFlow Industries, Inc. believes, to the best of our knowledge, that the information in the equipment manuals are accurate. In the event that technical or typographical errors exist, PFlow Industries, Inc. reserves the right to make changes to subsequent editions of the manual without prior notice to holders of this edition. The reader should consult PFlow Industries, Inc. if errors are suspected.

The customer’s right to recover damages caused by fault or negligence on the part of PFlow Industries, Inc. shall be limited to the amount paid to PFlow Industries, Inc. by the customer. The limitation of liability of PFlow Industries, Inc. will apply regardless of the form of action, whether in contract or tort, including negligence. Any action against PFlow Industries, Inc. must be brought within one (1) year after that cause of action accrues.

PFlow Industries, Inc. will not be liable for any loss, injury, or damage to persons or property, nor for direct, indirect, or consequential damage of any kind resulting from failure or defective operation of said material or equipment.

Warranty Procedures

All billing must be in accordance with our Warranty Procedures. Replacement of defective parts will be handled in accordance with the Return Materials Authorization (RMA) policy for PFlow Industries, Inc.

Pre-Authorization

- All warranty work must be pre-authorized by PFlow Industries, Inc. Customer Support Department prior to starting work.
 - Where distance and or experience may be more cost-effective, PFlow Industries, Inc. reserves the right to use alternate organizations.
 - Labor is defined as a maximum of two hours travel per call, plus reasonable on-site repair time as determined by PFlow Industries, Inc.
 - Local purchase of components must be pre-authorized.
1. Notify the PFlow Industries, Inc. Customer Support Department of the problem for authorization.
 2. PFlow Industries, Inc. will determine:
 - The cause of the problem.
 - Who will do the repair work.
 - The repair details involved.
 3. If PFlow Industries, Inc. decides that your organization or your subcontractor will do the work, an authorization number will be assigned which must be referenced on all subsequent paperwork.

NOTE *Notify PFlow Industries, Inc. by phone, FAX, or e-mail during the next business day if an event occurs during our non-working hours. Issuance of an authorization number does not guarantee approval and/or payment.*

Invoices

1. Submit an invoice for approval within 30 days after the date the work was completed. Payment is made 30 days after the date of approval.
2. A deduction from outstanding payments to PFlow Industries, Inc. for warranty is never authorized.
3. Invoices received without sufficient information will be returned. Invoices will be reconsidered for approval when complete documentation is received. All invoices must include, in detail, the following:

<input type="checkbox"/> PFlow serial number.	<input type="checkbox"/> Labor hours expended resolving the problem.
<input type="checkbox"/> Date the work was performed.	<input type="checkbox"/> Rates per hour.
<input type="checkbox"/> Description of the problem.	<input type="checkbox"/> Copies of receipts for materials purchased.
<input type="checkbox"/> Travel time incurred.	<input type="checkbox"/> Detailed description of work completed.



Read the Entire Manual

Important: carefully read the entire manual upon receipt of the VRC. Improper installation, alteration, adjustment, service, cleaning, or maintenance could result in death, severe injury, or property damage. Instructions and warnings must be read and thoroughly understood by all operators and users. PFlow Industries, Inc. recommends that the owner conduct regular staff training including safety instructions on a regular basis to avoid the risk of accident or damage to the VRC.

Following procedures other than those indicated in this guide to install, use, and maintain the VRC is considered inappropriate and may cause fatal accidents, personal injury, or property damage, in addition to invalidating the warranty.

Intended Purpose

The intended purpose of the PFlow Industries, Inc. Vertical Reciprocating Conveyor (VRC) is to provide a safe and simple means of moving materials only, up to the VRCs rated capacity, from one level to another. VRCs are **not** elevators. The VRC is exclusively intended for use in establishments where all operators have been trained to understand the purpose, limitations, and associated hazards of the VRC. Any other use of the VRC is strictly forbidden.

Potential Risks and Possible Misuse

PFlow Industries, Inc. has attempted to protect against as many hazards as possible. The following potential risks should be addressed before the VRC is put into operation:

- Risk of injury caused by falling products.
- Risk of injury caused by product extending beyond the confines of the carriage.
- Risk of injury caused by exceeding the weight capacity of the VRC.
- Hazards occurring at places where the VRC connects to incoming and outgoing conveyors.
- Risk of injury if any safety features are bypassed.
- Risk of injury due to the use of corrosive chemicals or water jet.

Safety Alert Symbols

To ensure your safety and the safety of those around you, it is important that you read, observe, and understand ALL safety precautions relative to a particular task. Safety precautions in the manual are labeled with an alert symbol followed by the word **DANGER**, **WARNING**, or **CAUTION**.



This is the safety alert symbol. It is used to alert you to potential physical injury hazards. Obey all safety messages that follow this symbol to avoid possible injury or death.



Indicates a hazardous situation that, if not avoided, will result in death or serious injury.



Indicates a hazardous situation that, if not avoided, could result in death or serious injury.



Indicates a hazardous situation that, if not avoided, could result in minor or moderate injury.

NOTICE Used to address practices not related to physical injury.



 **DANGER**



- Stay within the rated lift capacity.
- Make sure all safety devices are in place and operable before using the equipment. If any safety device is missing or inoperable, immediately remove the equipment from service.
- High Voltage! A licensed electrician must install all electrical connections and permanent wiring in accordance with applicable local or national electrical codes. Make sure the equipment is properly grounded in accordance with local electrical codes or, in the absence of local codes, with the current edition of the National Electrical Code NFPA No. 70.
- Falling column hazard! Make sure all beams, columns, posts, enclosure panels, and components are properly supported during installation. Illustrations may show the beams, columns, posts, enclosure panels, and components unsupported in order to make the equipment and installation instructions clearly understood.
- Keep clear of unsupported platforms. Stay out of the area under a raised platform. If a maintenance operation requires the carriage to remain in the raised position, refer to Bulletin 15709-0083 for additional information or contact PFlow Industries, Inc. Customer Support Department for assistance.

 **WARNING**



- This equipment can be dangerous if not used properly. Allow only competent adults who have been properly trained and authorized personnel to operate this equipment.
- Passengers are not permitted. Riding may result in death or serious personal injury.
- This equipment must be maintained to ensure safety. Allow only properly trained personnel to service the equipment. Implement a routine safety inspection plan and follow the recommended preventive maintenance schedule in the owner's manual.
- Lockout/tagout equipment before performing any adjustments or maintenance. If the equipment is not locked out, it could start unexpectedly and cause injury or damage. **Make sure all personnel are aware of the potential for stored energy to be present even after the power has been locked out.** Refer to ANSI Z244.1 and OSHA 29 CFR 1910.147 for minimum requirements for a lockout/tagout system. There may be additional country, state, or local requirements.
- Components and accessories may be heavy. To prevent serious injury, use the appropriate lifting apparatus when handling the components and installing the VRC.



WARNING

- If any defects relating to operating safety and reliability are detected or if any damage occurs, the VRC must be taken out of operation immediately.
- Before the VRC is put into operation, all VRC parts must comply with all relevant health and safety directives and regulations.
- Do not switch the main power supply on or start the VRC when persons are in contact with the VRC.
- Make sure that no persons or objects are within the range of any moving parts of the VRC.
- Climbing, sitting, walking, or riding on equipment while the equipment is in operation could result in death or serious injury.
- If this VRC needs to be modified in any way, contact PFlow Industries, Inc. for assistance. Do not make any unauthorized changes.
- Falling hazard! Close all gates before the carriage is moved. Never leave the lift unattended with the gates in the open position. Never close gates when a person is on the carriage or within the fenced area.
- Place the load in the center of the carriage platform to avoid shifting loads. Lock rolling casters in place. Make sure that any portion of the load does not overhang the perimeter of the carriage. Prevent unstable load conditions.
- Lockout/tagout the VRC before removing jammed product. Be aware that stored energy in the lift components may move or shift when the jam is removed. De-energize any circuit before work is begun.
- Do not overtravel! Stops, mechanical or electrical, must be in place to prevent the carriage from traveling beyond the intended floor level. Overtravel could cause permanent damage to the carriage or failure of the lifting mechanism.





Hydraulic Safety Precautions

WARNING



- Wear personal protective equipment, such as gloves and safety glasses, whenever installing, servicing, or checking a hydraulic system.
- Assume that all hydraulic hoses and components are pressurized. Relieve all hydraulic pressure before disconnecting any hydraulic line.
- Never try to stop or check for a hydraulic leak with any part of your body; use a piece of cardboard to check for hydraulic leaks.
- Small hydraulic hose leaks are extremely dangerous, and can inject hydraulic oil under the skin, even through gloves.
- Infection and gangrene are possible when hydraulic oil penetrates the skin. See a doctor immediately to prevent loss of limb or death.



- Ingesting hydraulic fluid is toxic and hazardous to people and wildlife. Symptoms may be skin irritation, weakness in the hands, intestinal bleeding, pneumonia, or death. Seek first aid immediately. Dispose of spilled fluids appropriately.



- Hydraulic fluid is flammable. Make sure you know where fire extinguishers are kept and how to use them. Do not weld on or near pipes, tubes, or hoses that are filled with fluid.
- Do not overfill the hydraulic oil tank. Any overflow could cause a fire. Immediately repair any hydraulic oil leaks and clean up any spills.
- Shut off all electrical power to the Vertical Reciprocating Conveyor (VRC) while filling the hydraulic oil tank.
- Materials and fluids soaked in hydraulic fluid should be stored in sealed metal containers and disposed of at proper places.



- Hydraulic fluid is slippery. Wipe up spills immediately to reduce the risk of falls or slips.



 **CAUTION**



- Inform personnel about the location and operation of emergency stops and power disconnection points.
- During operation, the surfaces of some components may become hot. Avoid touching hot surfaces or wear protective gloves.
- If any unsafe or unusual conditions are observed, stop the equipment and remove it from service. Report the condition to your supervisor.
- Paint overspray on the hydraulic cylinder rod will damage the packing seals and void the manufacturer's warranty. Cover exposed rods with removable plastic or soluble grease while painting or touching up the VRC.

Electrical Safety Precautions

 **DANGER**



High Voltage! Employees servicing or maintaining VRCs may be exposed to death or serious personal injury if hazardous energy is not properly controlled. De-energize any circuit before work is begun. Follow your facilities procedures or OSHA lockout/tagout (LOTO) procedures anytime maintenance or service is being performed on any electrical box or component.

 **CAUTION**

The incoming voltage source must match the voltage identified on the rating tag. The rating tag provides essential technical information required for any installation, maintenance, or repairs. Do not remove, damage, or modify the rating tag.

De-energize the Circuit



1. Lockout/tagout whenever any work, maintenance, or service is performed on any electrical box or component. Make sure circuits are de-energized before starting work, using a functional, properly rated, and well maintained multimeter or voltage sensing device. Make sure the device is rated for the level of voltage being measured and is sensitive enough for the application.
2. Use fuse pullers to change a fuse; **never** use bare hands, pliers, or screwdrivers.
3. Install covers on exposed electrical devices or wires to protect personnel from serious injury.
4. Ground all metal connection boxes, switch boxes, starting boxes, transformers, motors, limit switches, interlocks, and push-button stations to prevent shock to personnel.
5. When using a portable meter, never leave one lead dangling with the other lead connected. Anyone touching the lead may receive a shock through the meter.
6. Make sure that all is clear following lockout/tagout procedures before applying power to a circuit. This is necessary in order to protect personnel from injury and to prevent damage to the equipment.
7. Avoid accidental contact with equipment or conductors which are known to be energized or are **not** known to be de-energized. If it is necessary to work on equipment while it is energized, use extra care. Always test and repair equipment that appears damaged or delivers an electric shock.

Take time to be careful! Follow all safety precautions to prevent death or personal injury.

Electrical Safety Precautions

DANGER



High Voltage! To prevent serious injury, death, or property damage, all electrical connections and permanent wiring must be installed by a licensed electrician in accordance with applicable local or national electrical codes. Arc flash and shock hazard appropriate PPE is required. This equipment must be adequately grounded in accordance with local electrical codes or, in the absence of local codes, with the current edition of the National Electrical Code NFPA No. 70.

Working on Energized Circuits

When electrical repair or maintenance work is required that prohibits de-energizing the circuits involved, extreme caution must be used. The work should be completed only by authorized, well trained and supervised personnel who are fully aware of the dangers involved. All practical safety measure must be used to protect the personnel performing the required work. In addition to the NFPA No. 70 codes, the following precautions **must** be taken:

1. Remove all wristwatches, watch chains, rings, necklaces, metal appendages to clothing, oversized metallic belt-buckles, metal piercings, or loose clothing. These items have the potential to make accidental contact with energized surfaces. In addition, secure long hair with a hair net or cover with a plastic helmet.
2. Remove all hair barrettes or bobby pins. These items are electrically conductive and accidental contact may cause serious personal injury.
3. Wear dry clothing and shoes. Moisture should not be present on the soles of shoes. Water is electrically conductive and accidental contact may cause death or serious personal injury.
4. Insulate the worker from the ground. Cover any adjacent grounded metal surfaces with an insulating material. Suitable insulating materials are dry wood, rubber mats, dry canvas, dry phenolic material, or heavy, multi-ply paper (cardboard). Make sure that the insulating material has no holes present and there are no conductive materials (e.g., staples) embedded. Cover a sufficient area with the insulating material to make sure that adequate space is permitted for worker movement.
5. Use insulated tools when working on energized circuits or fuse box. These insulated tools must be rated to withstand the voltage of the energized circuits.

Notes for the Installation Electrician

The installation electrician must take the following precautions:

1. Locate and review the electrical schematics furnished with the equipment.
2. Verify the proper fit-up, wiring and operation of all required electrical components.
3. Mount the push button station out of reach of someone located on the carriage (approximately 6' [1,829 m]).
4. Wire standard lift limit switches on the chain tensioning assembly (see the job specific electrical schematic as required) for mechanical VRCs as follows:
If the tensioner chain becomes slack causing the arm on the limit switch to move down or if a strong tension is exerted on the tensioner chain causing the arm to move up, there is a break in the control power. The limit switches are designated with an LS# on the electrical schematic.

Section 4 | Important Safety Information



MATERIAL HANDLING SOLUTIONS

www.pflow.com
P 414 352 9000
F 414 352 9002
6720 N. Teutonia Ave.
Milwaukee, WI 53209





Safety First

The most common reason to access the area below a raised carriage deck is to clean debris from the pit or hoistway. This is best accomplished using a long handled broom or rake to avoid entry under the raised carriage deck. Entry under the raised carriage deck is acceptable only when unavoidable and then only if the proper precautions are taken. It is the user's responsibility to ensure that the following conditions be met before allowing qualified personnel to enter the area under the raised carriage deck.

- Work must be performed by qualified maintenance technicians.
 - ◇ A qualified person is defined as a person who, by possession of recognized degree or certificate of professional standing or by extensive knowledge, training, and experience, has successfully demonstrated his/her ability to solve problems relating to the subject matter and work.
- The facility has performed a Risk Assessment per ASME B20.1 5.16
 - ◇ Reference OSHA 3071 for Job Hazard Analysis
 - ◇ Reference CEMA Technical Report 2015-01, ASSE Z590.3, and MIL-STD-882 for Risk Assessment examples.
- A proper lockout/tagout (LOTO) procedure has been performed on the VRC.
 - ◇ Refer to ANSI/ASSE Z244.1-2003 (R2014), Control of Hazardous Energy — Lockout/Tagout and Alternative Methods, and OSHA Standard 29 CFR 1910.147, The Control of Hazardous Energy (Lockout/Tagout).
- At least two (2) means of support are used to secure the raised platform.
 - ◇ The lifting systems can be used as one means of support provided that no work is to be done on the hydraulic system or mechanical drive system and an appropriate LOTO has been performed on the VRC.
 - ◇ Additional means of support include adequately sized maintenance chains, maintenance pins, DeckLocks, or straps with shackles around the drivebase that are capable of supporting the weight of the carriage.

Minimize the Hazards

Every employee must be aware of the hazards before entering the area under a raised carriage. Take appropriate steps to minimize these hazards and any others that are identified. Some of the more common hazards are:

- Inadequate refuge space
- Confined space
- Improper air quality
- Inadequate lighting
- Improper access
- Tripping hazards
- Unsafe or lack of pit ladders
- The presence of moisture/water/oil
- Moving equipment

General Guidelines

- Where a VRC is operating in a multiple unit hoistway, that portion of the hoistway where the work is to be performed shall be fully separated or accessible equipment locked out.
- Ensure that all portable lights and tools are connected through a Ground Fault Circuit Interrupter (GFCI).
- Provide adequate lighting especially if in a shaftway.
- For a deep pit, never "jump" into the pit – always use a ladder.
- Use proper hand protection while cleaning the area beneath a raised carriage.
- Remove parts, lubricants, cleaning equipment, etc. from inside the pit.
- Do not stand on the hydraulic piping or electrical conduit.
- Never straddle over the traveling cable(s) if so equipped and protect it against damage.

Entrance Below a Raised Carriage Deck



MATERIAL HANDLING SOLUTIONS

www.pflow.com
P 414 352 9000
F 414 352 9002
6720 N. Teutonia Ave.
Milwaukee, WI 53209

Pit Access

Access to the area beneath the raised carriage deck can be gained through manual measures implemented by qualified maintenance technicians.

Manual Access

1. Call the carriage to the lower level.
2. Open the lower gate and bypass the gate open switch at the interlock or in the main control panel. If there is any confusion about how to do this, call PFlow Industries, Inc. Customer Support Department.
3. Barricade the lower level gate opening to prevent unintended access and provide hazard warning signs.
4. Verify that the carriage is empty. Raise the carriage to the upper level making sure all personnel are clear of the moving carriage.
5. Lockout the VRC in accordance with the facility lockout/tagout program.
6. Secure the carriage at the upper level using adequately sized maintenance chains, maintenance pins, or straps with shackles around the drivebase that are capable of supporting the weight of the carriage to provide additional safety.

NOTICE

Do not attempt to do any work on the lifting system (e.g., hydraulic system, motor drive). When work is to be done on the hydraulic system or mechanical drive system, a different procedure must be followed. The carriage must be landed on stands or secured by another means in order to prevent any weight from relying on the lifting means or when the hydraulic pressure is fully relieved. Consult PFlow Industries, Inc.

7. Return to the lower level and verify that the gate and the carriage does not move if the push-buttons are pressed. Wedge or block the lower level gate in the open position to prevent the gate from closing while someone is in the pit area.
8. Perform the necessary maintenance, adjustments, or cleaning under the carriage.
9. Exit the pit and remove the wedge or block holding the lower level gate open.
10. Reverse the process to return the VRC into service.



Unique Descriptions and Names

PFlow Industries, Inc. has incorporated, as well as created, a number of unique descriptions, names, and terminology for parts, components, and devices included in the Vertical Reciprocating Conveyor (VRC). This glossary includes these unique terms and other common terms to help understand this manual and the information it contains. In addition, the glossary will aid the user in communicating the correct information during troubleshooting and service situations. Although the wording and descriptions may sound familiar to the person who has read the manual, other terms and descriptions might not. It is recommended by PFlow Industries, Inc. that this glossary be reviewed before reading the remainder of this manual.

Alkyd paint	A fast-drying enamel paint, color-mixed per the customer's request, and applied using standard methods as specified by the paint manufacturer.
ANSI	American National Standards Institute: www.ansi.org
ASME	American Society of Mechanical Engineers: www.asme.org
Authorized person	Trained or qualified personnel approved to perform a specific duty or duties.
Back-frame	The vertical portions of the carriage on a cantilever VRC, typically a series D vertical support mast.
Backstop panel	Also known as a Mezzanine roll-off panel, this is a panel that is installed opposite the loading edge at upper loading levels of a VRC platform that does not penetrate a floor. The backstop panel helps protect personnel and/or products from falling off the platform when loading or unloading. This term should not be confused with the term "backstop" as defined in ASME B20.1.
Backstop	As defined by ASME B20.1; A mechanical device to prevent reversal of a loaded conveyor under action of gravity when forward travel is interrupted.
BVAC	A bi-panel vertical acting gate.
Cantilever	A style of VRC where the carriage rides along the guide columns that are located on the same side of the carriage. This style lift can accommodate loading on three sides; right, front, and left.
Capacity	The maximum load for which the VRC is designed.
Carriage	The entire structural assembly that travels on the guide columns and carries the load.
Carriage gate	A gate that is mounted directly on the carriage deck.
CEMA	Conveyor Equipment Manufacturers Association: www.cemanet.org
Chain	See Drive chain, Lift chain and Roller chain.



Chain Driven Live Roller (CDLR)	A horizontal conveyor that is driven by separate loops of chain or a continuous chain. The chain contacts all roller sprockets, depending on the type and function of the horizontal conveyor. Either double or single sprockets are fitted to the horizontal conveyor rollers.
Chain Guide Tube	A tube welded to the back side of the VRC column that encloses the lift chain and tensioner chain.
Chain tensioner	A device that monitors the lift chain tension. If the lift chain is too tight, becomes slack, or breaks, the limit switch mounted on the chain tensioner will trip and remove control power.
Columns	The vertical structural members in which the wheelblocks attached to the carriage travel up and/or down.
Column splice	Columns shipped in more than one piece must be joined in the field during installation. Field assembly and welding is required.
Constant Pressure Push Button	A push button which must remain pressed and maintained by the operator in order to perform a desired operation. If the push button is released, the desired operation will stop.
Controls	Any combination of electrical devices used to control the operation of a VRC. This normally includes push buttons, relays, limit switches, interlocks, etc.
Control Panel	An enclosure housing various electrical components that control the VRC.
Control voltage	The control voltage is typically provided by the control transformer and is used to energize the various low voltage electrical devices.
Conveyor, Vertical Reciprocating	See Vertical Reciprocating Conveyor (VRC).
Dead load	A static load that is a permanent force, acting on a structure (see Platform).
Deck	The floor of the carriage (can be smooth plate, tread plate, or open).
DeckLock System	An added measure of safety to prevent uncontrolled descent of the carriage.
Diagonal drop bar	Load-defining bar and snap chain across operating end(s) of the carriage to define the load area on the platform which may minimize load movement. The diagonal drop bar is hinged at the base and swings down. This is not a load stop.
Direct acting cylinder	The cylinder which transmits lifting force directly to the carriage rather than through the use of cables, pulley, or chains.
Drivebase assembly	Gear reducer, brake motor and mechanical components that power the chain that lifts and lowers the carriage for mechanical VRCs. This assembly is typically mounted at the top of the lift guide columns.



Drive chain	Drive chains on the F series mechanical VRC, through a series of a shaft and sprockets allow the carriage to be raised and lowered.
Drift	The action of a lift carriage slowly dropping, usually due to slight internal leaks in a hydraulic system or mechanical slippage of a motor brake.
EBVAC	An electrically powered bi-panel vertical acting gate.
Effective width/length	Refers to usable space for the materials load on the carriage, not the overall dimensions which includes space allowed for carriage side guards and snap chains.
Electrical cable	Electrical cables consist of at least two conductors contained within a protective outer cover.
Enclosure (lift guarding)	Structure surrounding a VRC to prevent outside interference with its normal operation and to safeguard personnel. Typically 8' (2438mm) high panels composed of expanded metal or other materials that will prevent a 2" (51mm) diameter ball from passing through (ASME B20.1 requirement).
Epoxy coating	Abrasion-resistant, two-part industrial-strength protective coating system applied over sandblasted and primed steel or direct to metal. The epoxy coating is ideal for outdoor, chemical, or caustic wash-down environments or applications where standard alkyd enamel is viewed as insufficient.
EVAC	An electrically powered single panel vertical acting gate.
Expanded metal (EM)	A sheet of metal uniformly slit and stretched, forming diamond-shaped openings in the metal sheet. Expanded metal is a one piece construction that will not unravel under normal circumstances and will hold its shape. Expanded metal comes in a standard (raised) or flattened diamond pattern in a variety of gauges, opening sizes, materials and sheet sizes.
Explosion proof (EXP)	Electrical devices (e.g., control panels, motors, limit switches) that are designed to operate safely in a specific location or area where potentially explosive environments can or do exist.
Floor-to-Floor distance	The distance from one operating floor level to the adjacent operating floor level (see Vertical travel).
Full Height Enclosures (FHE)	Structure surrounding the full height of a VRC to prevent outside interference with its normal operation and to safeguard personnel. Typically panels composed of expanded metal or other materials that will prevent a 2" (51mm) diameter ball from passing through (ASME B20.1 requirement).
Gate	A device that opens and closes manually or automatically to allow access to the carriage for loading and unloading. The gate is normally a swing, sliding, or vertical acting device constructed of similar expanded metal as the enclosure (see specific gate type).



General Arrangement (GA) drawing	The drawing produced by PFlow Industries, Inc. which shows the VRC lift, gates, and enclosures. The drawing may show but does not specify building details.
Guarded by location	Describes moving parts so protected by the parts remoteness from the floor, platform, walkway, or other working level, or by the parts location with reference to the frame, foundation, or structure to reduce the foreseeable risk of accidental contact by persons or objects. The parts remoteness from foreseeable, regular, or frequent presence of public or employed personnel may constitute guarding by location in reasonable circumstances. (See ASME B20.1 standard)
Guide angles	Guide angles are attached to the guide column to help capture and contain the guide wheels in the columns and guide the carriage.
Guide column	The structural members connected to the carriage that guide the carriage travel up and down.
Header	Header refers to the horizontal structure spanning the width of the carriage or gate. The carriage header defines the load height on straddle units.
HMI (Human Machine Interface)	The user interface in the control system that provides graphic control of the VRC. The HMI communicates with the programmable logic controller (PLC).
Hollow shaft	VRC mechanical shaft of the mechanical drivebase which penetrates the gear motor rather than coupling to the gear motor. This minimizes wear points.
Hydraulic cylinder	A device which converts fluid power into linear force and motion. The hydraulic cylinder usually consists of a movable element such as a piston and piston rod, plunger or ram, operating within a cylindrical bore.
Hydraulic power unit	Refers to motor, pump, and reservoir assembly. The reservoir is shipped with oil. Most hydraulic power units come with the control panel attached and pre-wired to the hydraulic pump.
Incoming voltage	The main voltage being supplied for operation of the equipment.
Interlock (Gate/Door)	An electro-mechanical locking system used on the gates or access doors of a VRC. The system prevents the VRC operation unless all such gates or access doors are closed. The system also prevents the opening of any such gate or access door unless the VRC carriage is present at that particular landing or opening.
Intermediate level	A floor level or levels between the uppermost and bottommost operating floor.
Junction box	An electrical control box used to join, centralize, and distribute wiring from different locations.
Keylock control	A keyed push button station that prevents unauthorized use of the VRC.
Kick plate	A curb on the outermost edge of the inoperable sides of the carriage deck which is designed to contain product and is a minimum of 4" (102mm) high.
Knock-down (KD)	Lift components shipped in two or more pieces. Typically field welding is required (e.g., KD carriage, KD headers, KD uprights, KD gates, etc.).



Landing	A permanent-working surface at a fixed elevation used for loading or unloading the carriage.
Lift chain	A chain that lifts the carriage and load.
Lift location light	Illuminated push button that indicates at which level the carriage is located.
Lifted load	The total weight that the VRC is designed to lift at a specific speed. Typically, this is the dead load plus live load (see Rated load).
Limit switch	An electrical device which is used to control the carriage position and monitor various mechanical devices.
Load pattern	<p>A method to describe the direction a load can be moved on and off a carriage at different operating floors or levels. These can be used in combinations.</p> <ul style="list-style-type: none"> ● “C” load pattern: Carriage configuration allowing a load/unload opening on one side of the carriage deck. ● “Z” load pattern: Carriage configuration allowing a load/unload opening on opposite sides of carriage deck. ● “90 degree” load pattern: Carriage configuration allowing a load/unload openings at right angles on the carriage deck.
Load test	The carriage is loaded to rated capacity, and the lift is operated.
Macropoxy	Macropoxy is a fast drying, polyamide epoxy designed to protect steel in industrial exposures. Ideal for protection of sharp edges, corners, and welds.
Mechanical stop	A mechanical means of stopping travel at a fixed position.
Momentary contact push button	A push button which only has to be pressed for an instant to activate the desired operation.
Non-operating end	The side(s) of a carriage not used for loading/unloading. Handrails or expanded metal sides and kick plate are normally supplied as minimum guarding.
Operating end	The side(s) of the carriage used for loading/unloading. At a minimum the side(s) are normally equipped with a safety chain as guarding.
Overall dimension	The outside dimension of the carriage structure or the entire lift.
Overtravel limit switch	A safety device provided on mechanical VRCs to stop carriage travel beyond the uppermost or lowermost floor level if the floor level positioning limit switch fails.
Photo eye	Photoelectric sensor that uses a focused beam of light to span the distance to a reflector. The VRC controls receive a signal when the reflected beam of light is detected by a sensor.
Pit	A depression in the floor a minimum of 1" (25mm) deeper than the carriage profile, which allows the carriage deck to be flush at operating floor or level.
Platform	The structure that forms the floor of the carriage and that directly supports the load (see Deck).
Pneumatic gate operator	A device that requires in-plant, clean and dry air to automatically open and close a gate. The device can be operated by either manually through the use of pull cords or push buttons, or automatically through the use of a PLC.



Pressure switch (hydraulic)	A sensor which detects hydraulic pressure. The sensor can be set to trip at a predetermined pressure. When this pressure setting is reached, the pressure switch will activate, opening the control circuit and stopping the pump motor.
Programmable Logic Controller (PLC)	A micro-processor based device that controls the VRC or Cartveyor™ through a resident software program.
Push-button (PB) station	The wall mounted, pedestal mounted, or hand held device used to control the operation of the VRC.
Qualified person	A person, who by possession of a recognized degree, certificate, professional standing, or skill, and who by knowledge, training and experience, has demonstrated the ability to deal with problems relating to the subject matter, the work, or the project.
Ramp	An access ramp used to load on and off of a carriage deck.
Rated load	The load the VRC is designed for and installed to lift at a rated speed (see Lifted load).
Reflector	A plastic, prismatic object used to reflect a beam of light emitted from a photoelectric sensor.
Roll-off panel	See Back-stop panel.
Roller chain	The type of chain drive most commonly used for transmission of mechanical power. The roller chain consists of a series of short cylindrical rollers held together by side links and connecting pins. The roller chain is driven by a toothed wheel called a sprocket.
Safety cam	Spring-loaded, hardened steel cam directly attached to the lift chain or gate chain that engages if the lift chain or gate chain breaks or slackens, preventing the carriage or gate panel from dropping more than a few inches.
Side guards	A protective enclosure on the outermost edge of the inoperable sides of the deck welded to the carriage to contain load. Can be rails, sheet steel, or expanded metal.
Slack chain device	A device that monitors a chain and trips if the chain goes slack. If the chain becomes slack or breaks, the limit switch mounted on the slack chain device will trip and remove power to the circuit.



Spliced guide column	Guide column that is fabricated and delivered in two or more sections necessitated by manufacturing, handling, or installation constraints.
Sprocket	A wheel typically mounted on a shaft. The wheel has a row of teeth around its edge that fit into the links of a chain.
Straddle	A style of VRC where the carriage rides between two guide columns that are located on opposite sides of the carriage. This style of lift will accommodate “C” and “Z” type loading patterns.
Top of roller (TOR)	Top elevation of a horizontal conveyor system roller which is also the lower elevation of the load.
Touchscreen	See HMI.
Transom	A panel or panels used to close an enclosure opening above the VRC entrance.
Travel	The difference in elevation between the bottommost level of the carriage platform and the uppermost level of the carriage platform, regardless of whether the carriage is pit or floor mounted.
UHMW (Ultra-High Molecular Weight)	An abrasion-resistant, high-impact, polyethylene material used throughout the VRC to protect and/or guide moving parts.
Uprights	The portion of the carriage that houses the wheels that guide the carriage between the columns.
VAC	A single panel vertical acting gate.
VFD (Variable-Frequency Drive)	A VFD is a type of drive used in electro-mechanical drive systems to control AC motor speed and torque by varying the motor frequency and voltage.
Velocity fuse	A device that senses hydraulic flow across a control orifice when the pressure differential exceeds a predetermined amount. A spring-biased poppet closes, shutting flow to the damaged hydraulic circuit and prevents the lift carriage from descending.
Vertical travel	Distance the carriage deck travels; floor-to-floor or total distance (see Travel).
Vertical Reciprocating Conveyor (VRC)	A reciprocating power actuated lifting device (not designed to carry passengers or an operator) that receives loads on a carriage and transports these objects from one operating elevation to another.
VRC specification sheet	PFlow Industries, Inc. informational data sheet providing general information on a specific VRC.
Wheelblock assembly	Sub-assembly fastened to the carriage upright that contains the guide roller elements and safety cam for the chain driven VRC lift. The lift chain is typically attached to the wheelblock assembly safety cam.



Gate Types:

Single swing gate

This type of gate hinges on one side and latches on the other, may be either right or left-hand swing. Clear space is required in front of the VRC for the gate to swing open.

Bi-parting swing gate

The bi-parting, swing gate has hinges on each side and latches in the center. Clear space is required in front of the VRC for the gates to swing open.

Single panel vertical acting gate (VAC)

The VAC gate panel closes to the floor and opens in the upward direction.

Double panel vertical acting gate (BVAC)

The BVAC gate is the same as the single panel VAC above in operation and use except the two (2) panels telescope from a nested position.

Horizontal sliding gate

The horizontal sliding gate operates in the same manner as a vertical acting gate except the gate functions in the horizontal direction.

Roll-up door

The roll-up door can be anything from an industrial type roll-up steel door to self-storage facility type door.



D Series Hydraulic

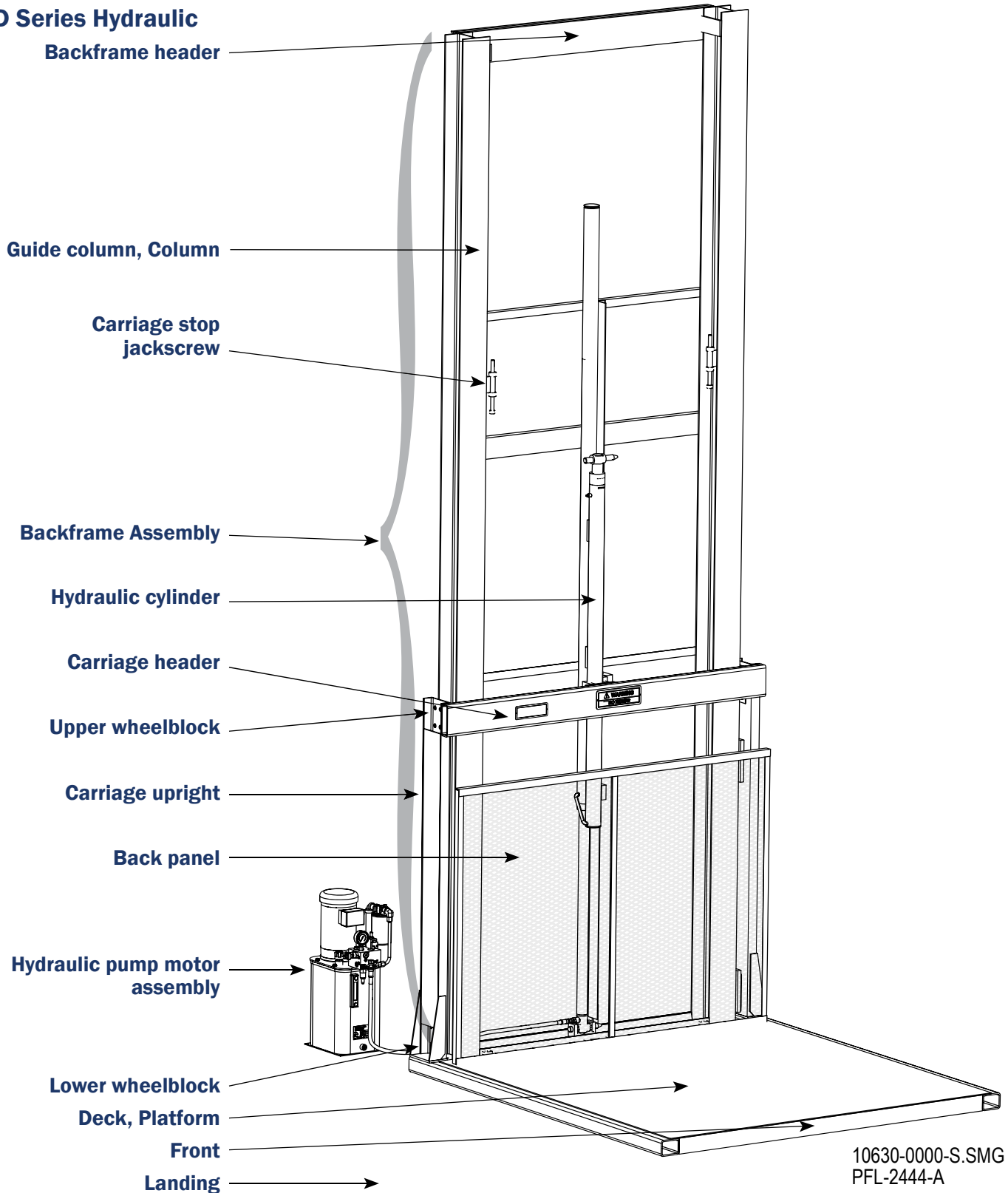

Push-Button (PB) station

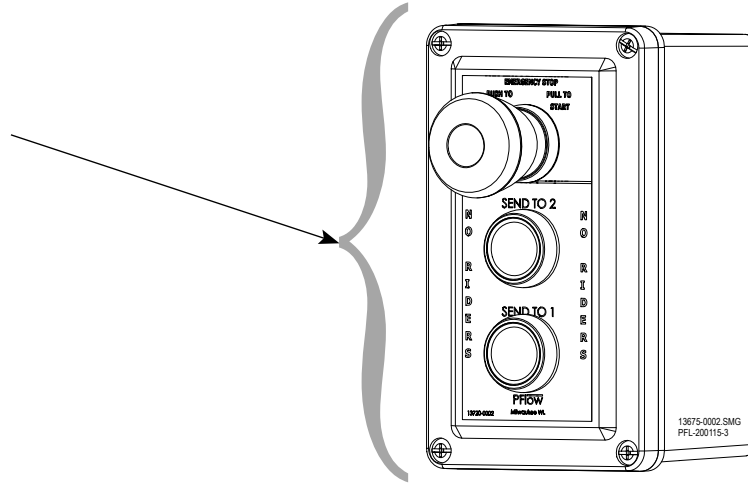

Interlock

Gate header

Gate panel

Bi-parting swing gate

Gate post

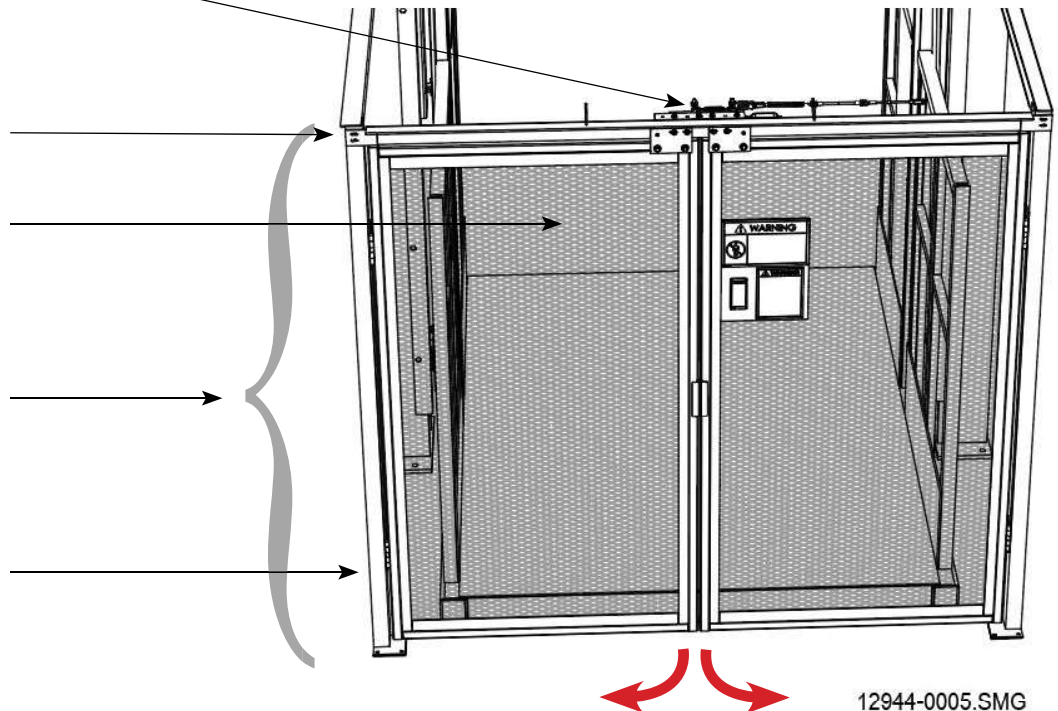

12944-0005.SMG
PFL-1081-2



Arrival

A fork truck capable of lifting approximately 2,000 lbs. (907 kg) is required. Larger sections may require a heavier lifting capacity fork truck or crane. Refer to the shipping weights for the equipment required for your job. Prior to shipping, PFlow Industries, Inc. takes pictures of all the items shipped, contents of the parts crate, and individual boxes to make sure the shipment is complete.

NOTICE The material in the boxes, cartons, etc. are delivered to the carrier agent complete and in good condition. Report shipping damage or discrepancies immediately to the PFlow Industries, Inc. Customer Support Department. *PFlow Industries, Inc. is not responsible for damage due to shipping or receiving once the equipment has left the factory nor will PFlow Industries, Inc. file any claims for damage that may occur.*

Inspection

Upon receipt, conduct an immediate inspection while the equipment is still on the truck or immediately after it is moved to the receiving area. Do not wait until after the equipment is moved to a storage area.

Verify that the number of items on the Bill of Lading agrees with the number of items delivered. Examine all pieces to determine if damage has occurred during transit. Do not sign a delivery receipt or a freight bill until a proper count has been made and inspection of all packages are complete. Should damage occur in shipment, it is a matter between the carrier and the consignee. In such cases, the carrier is assumed to be responsible for the safe delivery of the equipment, unless negligence can be established on the part of the shipper.

Verify the dimensions of the delivered materials against the PFlow Industries, Inc. General Arrangement (GA) drawing. If anything is missing or incorrect, contact the PFlow Industries, Inc. Customer Support Department immediately. Failure to notify the PFlow Industries, Inc. Customer Support Department may affect the completion time of the installation. The warranty does not cover lost time and/or additional trips for missing or damaged components.

Transportation Damage and Claims

1. Note all visible loss or damage that has occurred directly on the carrier's delivery receipt.
 2. Have the driver sign the delivery receipt. If the driver refuses to sign, make a notation of this refusal on the receipt.
 3. If the driver refuses to allow inspection, write the following on the delivery receipt: **"Driver refuses to allow inspection of containers for visible damage."** Have the driver sign the delivery receipt.
 4. Contact the carrier's office immediately upon finding damage and request an inspection. Mail a written confirmation to the carrier's office with the time, date, and the person called.
 5. Save any packages and packing material for further inspection by the carrier.
 6. Promptly file a written claim with the carrier and attach copies of all supporting paperwork. Report all hidden damage directly to the freight carrier within seven days of delivery.
-

Shipping Photograph
Examples



Parts Crate



Parts Crate Contents



Shipping Photograph Examples

Schematic

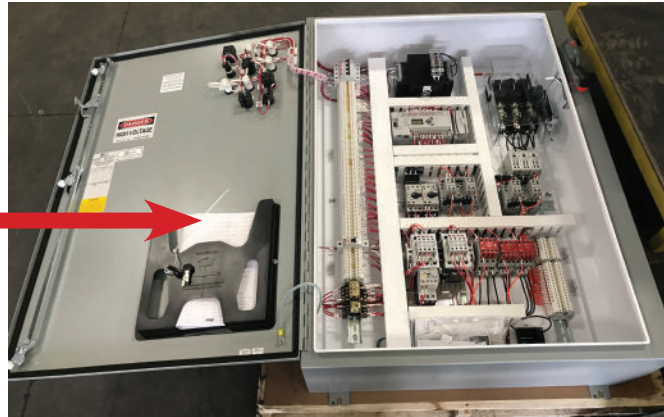

Shipping Packet

The shipping packet contains the Owner's Manual, installation instructions, General Arrangement drawing, electrical schematic, and additional information applicable to the installation.

An additional copy of the schematic is inside the control panel.

Unpack the Equipment

- Save all packing materials for inspection by the carrier.
- Cut and remove the restraining straps.
- Remove the protective shrink wrap and cardboard material.
- Remove all wooden retaining blocks and crating.
- Remove the materials from the pallet.
- Dispose of the packing material in an environmentally responsible manner.

Return Materials Authorization (RMA)

All replacement components needed as a result of any damage will require a purchase order, authorization number, and compliance with PFlow Industries, Inc. Return Materials Authorization (RMA) procedures. The RMA number shall be obtained from PFlow Industries, Inc. Customer Support Department. The RMA number helps to identify and track the component when returned to PFlow Industries, Inc.

Warranty Work

Warranty procedures are included in this manual. All warranty work must be pre-authorized by the PFlow Industries, Inc. Customer Support Department prior to starting work.

1. Notify the PFlow Industries, Inc. Customer Support Department of the problem for authorization.
2. PFlow Industries, Inc. will determine:
 - The cause of the problem.
 - Who will do the repair work.
 - The repair details involved.
3. If PFlow Industries, Inc. decides that your organization or your subcontractor will do the work, an authorization number will be assigned which must be referenced on all subsequent paperwork.

NOTE Notify PFlow Industries, Inc. by phone, FAX, or e-mail during the next business day if an event occurs during our non-working hours. Issuance of an authorization number does not guarantee approval and or payment.



Recommended Tools

The following is a list of recommended tools necessary to expertly install the equipment to industry standards. This is only a guideline. Individual sites and applications may require additional items.

	Welding Machine and Equipment (Helmet, Gloves, Rods)		Socket Set: 1/2" Drive Sockets Sizes to 1-1/4"
	Lifting Cables, Straps, Slings or Chains: 2,000 lb. (907 kg) Capacity* (Minimum)		Hammer Drill & Bits: (1/4", 3/8", 1/2" Anchors; 4" Length Minimum)
	Chain Fall: 2,000 lb. (907 kg) Capacity* (Minimum)		Open or Box-End Wrenches to 1-5/16"
	Scissor Lift (optional but helpful)		Electric Drill and Drill Bits
	Fork Lift: 2,000 lb. (907 kg) Lifting Capacity* (Minimum)		Hex Keys to 3/8"
	Step Ladder(s)		Tap Set: 1/4-20 to 3/4-10
	Come-Along Tool		Sledge Hammer
	Disk Grinder		Hack-Saw, Reciprocating Saw, or Portable Band-Saw
	"C" Clamps		Extension Cords
	Drift Punch		Chalk Snap-Line
	Carpenter's Framing Square		Plumb Bobs
	Spirit Level: 4' (1,22 m) Long		25' (7,62 m) Measuring Tape
	Vacuum		Rags
	String		Fire Extinguisher
	Pry bar		Portable Light

**Larger sections may require a
heavier lifting capacity.*



Before You Begin

Read this entire manual.

**Pre-Installation
Responsibilities**

Proper preparation of the job site before beginning the installation can mean the difference between an installation that is safe and smooth and an installation that is difficult. Being aware of who is responsible for the listed activities will make sure the installation is a smooth process.

PFlow Industries, Inc. recommends that an installer with knowledge and experience on how to rig and erect structural steel discuss not only these items but all other concerns directly with the people on the job site.

A pre-installation job site visit is always recommended and considered to be included in the responsibilities of the mechanical installer.

**End User
Responsibilities**

1. Assign the authorized on-site contact.
2. Provide the contact information for the authorized on-site contact.
3. Determine the work hours allowed to work on-site.
4. Arrange for other trades or in-plant production to avoid conflict with the proposed installation schedule or between trades.
5. Determine the work procedures and safety guidelines particular to the job site.
6. Communicate on-site safety meetings prior to beginning the installation.

**End User and/or
Mechanical Installer
and/or Electrical
Installer
Responsibilities**

1. Secure any required job site, local, or state permits before beginning the installation.
2. Determine if a local inspection and sign-off is required after the installation has been completed.
3. Unload and transport the equipment to the installation area.
4. Determine storage options (if applicable). Storing the equipment outside will void the warranty. If the equipment is stored indoors for a month or longer, consult PFlow Industries, Inc. for maintenance procedures required to keep the warranty in effect.
5. Prepare all necessary job site areas (e.g., pit, floor opening, adequate bracing locations, shaftway openings, doorways) for the installation.
6. Coordinate any job site or building modifications necessary to get the equipment to the installation area.
7. Determine if the weight and the size of the components exceed the lift requirements to handle and lift the heaviest load. If the weight of the load is in question, please contact the PFlow Industries, Inc. Customer Support Department.
8. Locate the pick-point capable of lifting and handling the necessary components.
9. Determine approved bracing locations and attachment points on the job site. Make sure that the bracing attachment points will withstand the static lateral load for bracing the lift. Details are called out on the GA drawing.
10. Make sure that the floor under the columns will withstand the base plate loading stated on the VSP spec sheet.



**Mechanical Installer
Responsibilities**

1. Conduct a pre-installation job site visit.
2. Review the General Arrangement (GA) drawing for any discrepancies between the GA drawing and the job site.
3. Compare the dimensions listed on the GA drawing to the dimensions on the actual job site.

NOTE *Discrepancies in the pit length, pit width, pit depth, overhead clearances, and a pit that is not square or level are just a few items that could create a problem. These discrepancies must be addressed immediately with PFlow Industries, Inc.*

4. Report any discrepancies to the PFlow Industries, Inc. Customer Support Department.
5. Determine if additional bracing material is required.
6. Complete mechanical erection of the equipment as sold by PFlow Industries, Inc. and called out on the GA drawing, and follow all instructions in the installation manual and safe work procedures.
7. Mount all electrical devices at non-union job sites.
8. Return trip upon completion of the electrical installation and be present for the final checkout, adjustments, and training. Complete and return the Installation Completion Checklist to PFlow Industries, Inc. Customer Support Department at csd@pflow.com

**Electrical Installer
Responsibilities**

1. Review the General Arrangement (GA) drawing for any discrepancies between the GA drawing and the job site.
2. Report any discrepancies to the PFlow Industries, Inc. Customer Support Department.
3. Complete electrical connection of the equipment as sold by PFlow Industries, Inc. and shown on the electrical drawings and GA drawing.
4. Follow all instructions in the installation manual and safe work procedures.
5. Be present for the final checkout, adjustments, and training. Complete and return the Installation Completion Checklist to PFlow Industries, Inc. Customer Support Department at csd@pflow.com



Before You Begin

Read this entire manual.

General Arrangement (GA) Drawing

Job site conditions may be different than those listed on the GA drawing. This drawing includes configuration and dimensional data specific to the job site:

- Job number
- Equipment dimensions
- Clearance dimensions
- Static lateral load
- Applicable options

The VRC can only be used according to the specifications given in this manual and the General Arrangement (GA) drawing. If the VRC is to be used outside the original design, contact the PFlow Industries, Inc. Customer Support Department to determine if the intended use is possible.



WARNING

Inappropriate and/or modified use of the VRC can result in dangerous safety issues and/or damage. If this VRC needs to be modified in any way, contact PFlow Industries, Inc. for assistance. Do not make any unauthorized changes.

Obtain written confirmation from PFlow Industries, Inc. before using the VRC in a modified or unspecified manner. PFlow Industries, Inc., cannot be held liable for any accidents and/or damages that may occur through inappropriate or unauthorized use of the VRC.

1. Locate the PFlow Industries, Inc. GA drawing in the shipping packet inside the parts crate.
2. Review the GA drawing for any discrepancies.
3. Compare the dimensions listed on the GA drawing to the dimensions of the actual job site and the materials received.

NOTE *Discrepancies in the pit length, pit width, pit depth, overhead clearances, and a pit that is not square are just a few items that could create a problem. These discrepancies must be addressed immediately with PFlow Industries, Inc.*

4. Report any discrepancies to the PFlow Industries, Inc. Customer Support Department.

Contact the PFlow Industries, Inc. Customer Support Department with any questions or concerns at any time throughout the installation of this equipment.

Sample GA Drawing

The sample drawing shown is only an example and is not applicable to this VRC.

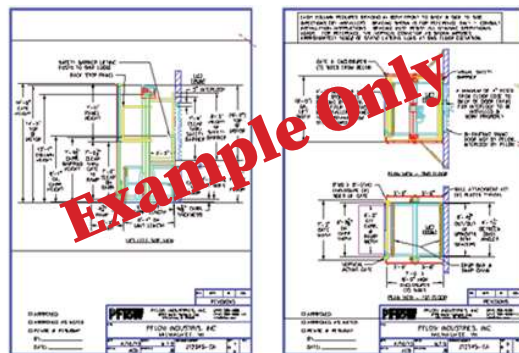

Section 8 | Job Site vs General Arrangement Drawing



MATERIAL HANDLING SOLUTIONS

www.pflow.com
P 414 352 9000
F 414 352 9002
6720 N. Teutonia Ave.
Milwaukee, WI 53209





Frequently Asked Questions

Proper preparation of the job site before beginning the installation can mean the difference between an installation that is smooth and an installation that is difficult. PFlow Industries, Inc. has prepared a list of site specific questions to investigate:

1. Is 3-phase power available for the installation work?
2. Is welding permitted?
3. Is a “hot permit” required?
4. Is a fire watch required? Are there special welding requirements (e.g., special coatings such as epoxy paint, or hot dipped galvanized steel)?
5. Are there any protrusions or rough spots in the floor level or wall space that could interfere with the installation or the operation?
6. Are the floors level?
7. Can the equipment pass through all openings, doorways, hallways, and shaftway openings?
8. Is there other non-PFlow Industries, Inc. equipment to be integrated with the PFlow Industries, Inc. VRC components?
9. Is a job specific bracing drawing required?
10. Is the work site union or non-union?
11. Is the customer’s forklift available for use?
12. Do the weight and size of the Vertical Reciprocating Conveyor (VRC) components exceed the capability of the on-site equipment to handle and lift the VRC components? If the weight of the load is in question, contact the PFlow Industries, Inc. Customer Support Department.
13. Is there a pick-point capable of lifting the necessary lift components?

Contact the PFlow Industries, Inc. Customer Support Department with any questions or concerns at any time throughout the installation of this equipment.

Section 9 | Frequently Asked Questions



MATERIAL HANDLING SOLUTIONS

www.pflow.com
P 414 352 9000
F 414 352 9002
6720 N. Teutonia Ave.
Milwaukee, WI 53209



Sequence Of Installation

The next few pages are only a representation of the sequence of installation for an open mezzanine application. Refer to the detailed instructions for each sequence included in the installation manual.

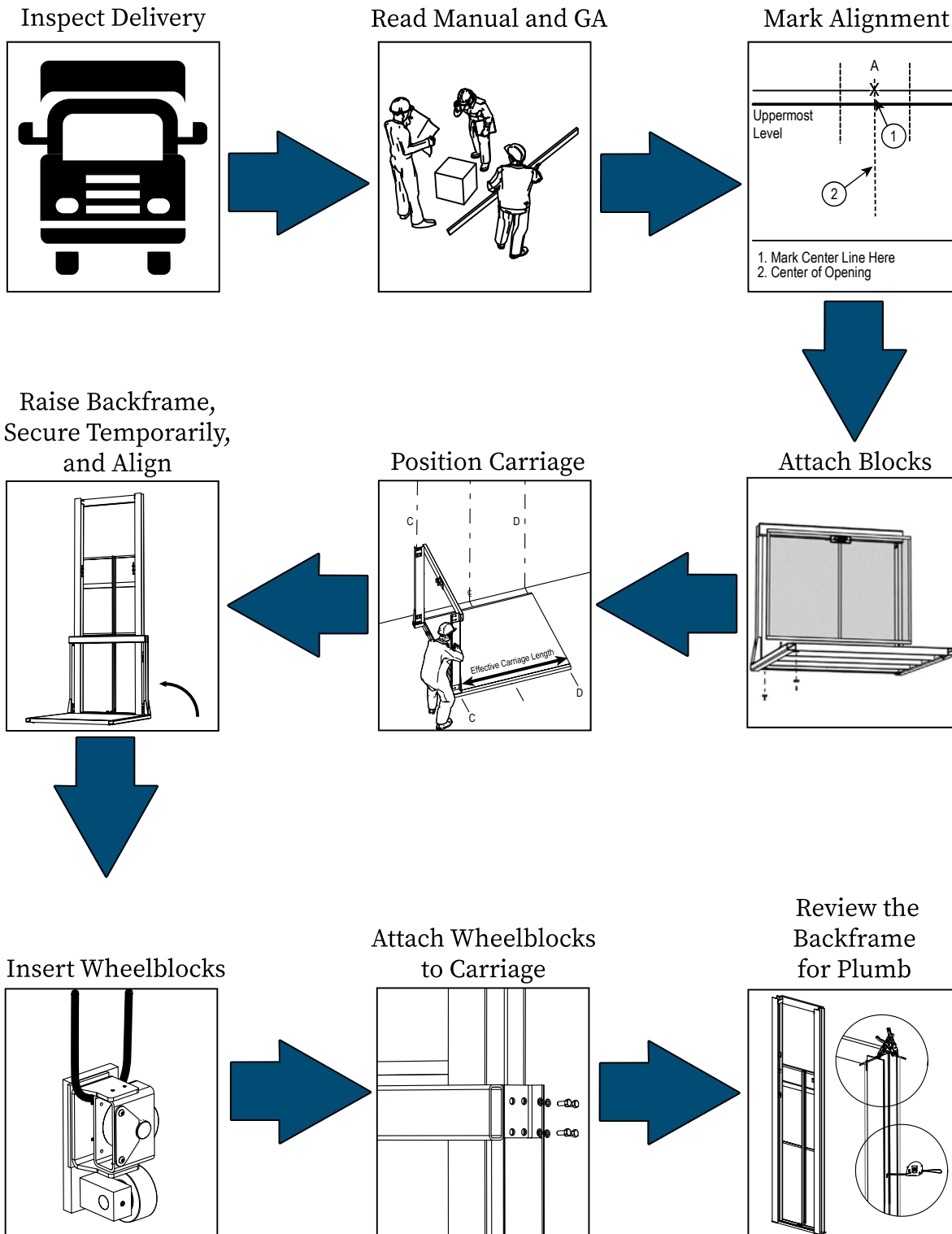

Section 10 | Sequence of Installation



MATERIAL HANDLING SOLUTIONS

www.pflow.com
P 414 352 9000
F 414 352 9002
6720 N. Teutonia Ave.
Milwaukee, WI 53209

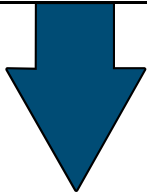

Bolt Backframe

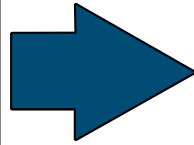
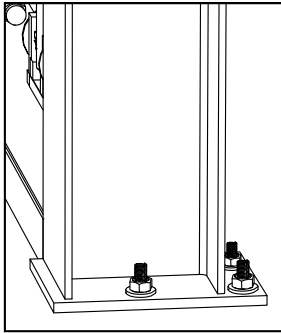

Attach Cylinders

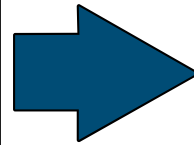
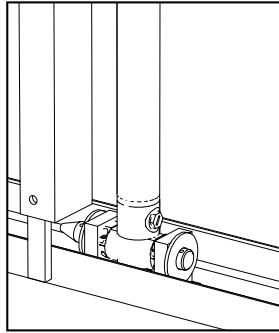

Install Final Bracing

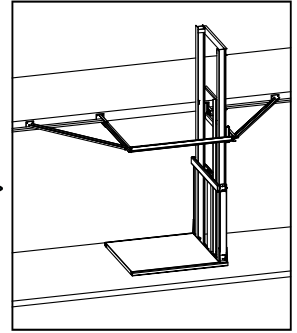

Plumb Gates

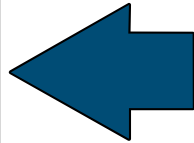
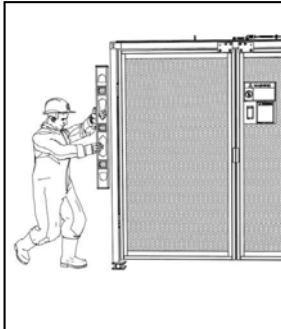

Position Gates and Secure Gate Posts

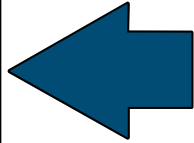
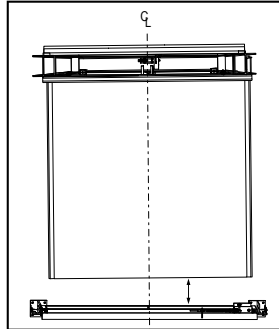

Assemble Gates

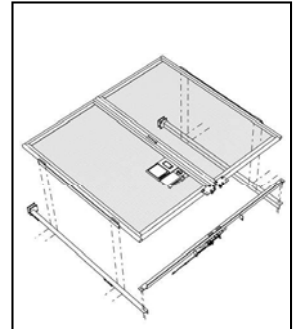

Brace and Weld Gates

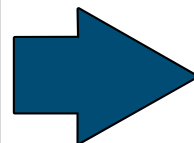
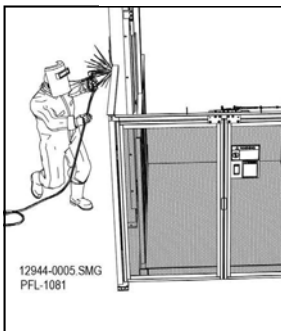

Install Keepers

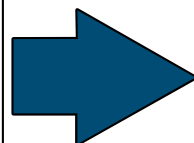
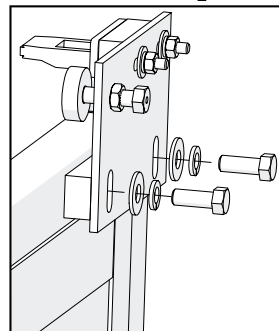

Install Interlocks

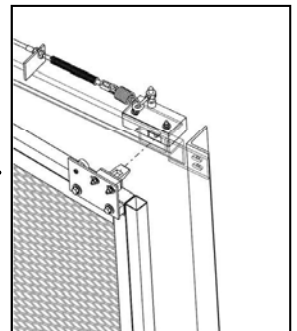



Install Enclosures

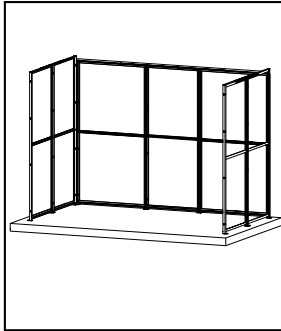

Attach Signage



Electrical Wiring

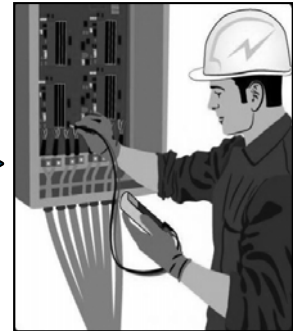

Start-Up

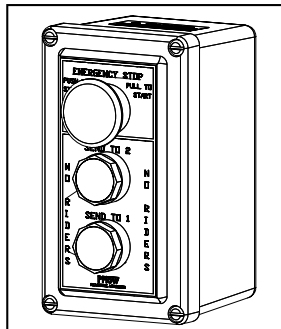

Connect Hose to Hydraulic Pump

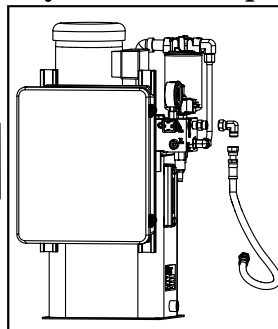

Connect Hose to Cylinder

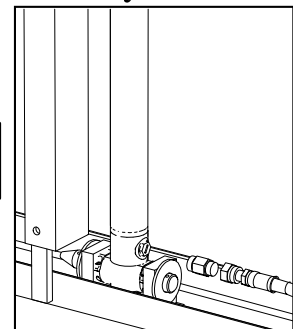

Checklist



Complete the Questionnaire



Section 10 | Sequence of Installation



MATERIAL HANDLING SOLUTIONS

www.pflow.com
P 414 352 9000
F 414 352 9002
6720 N. Teutonia Ave.
Milwaukee, WI 53209





Before You Begin

Read this entire manual. Before starting the installation, verify the job site dimensions and the dimensions of the delivered materials against the PFlow Industries, Inc. General Arrangement (GA) drawing. If the site conditions or the delivered materials do not match the GA drawing, please consult the PFlow Industries, Inc. Customer Support Department.



Falling column hazard! The installation of this equipment requires a qualified installer with extensive knowledge and experience on how to rig, erect, and support structural steel.

NOTICE

A qualified person is defined as a person who, by possession of a recognized degree or certificate of professional standing, or by extensive knowledge, training, and experience, has successfully demonstrated his/her ability to solve problems relating to the subject matter and work.

Verify Job Site Dimensions and Carriage Orientation

The Vertical Reciprocating Conveyor (VRC) was built using dimensions supplied to PFlow Industries, Inc. as listed on the General Arrangement drawing (e.g., floor-to-floor distance, pit depth, upper level opening, etc.).

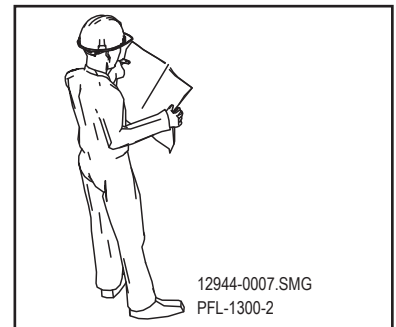

Verify Site Dimensions Figure 11-1

These instructions are representative of an open mezzanine installation in which the carriage is placed in position before the backframe is placed in position.

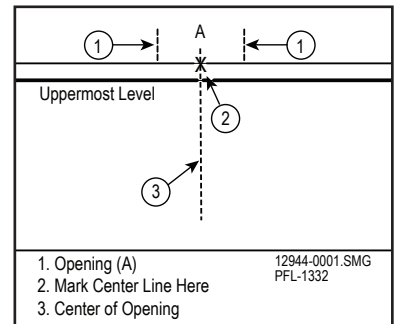

Initial Layout Figure 11-2

Mark Alignment

1. Verify that the column installation (e.g., no spliced backframe, no restricted shaftway, etc.) allows the carriage to be placed before the columns are installed.
2. Mark the center line position of the opening at the uppermost level. See Figure 11-2.
3. To allow clearance for carriage movement, drop a plumb line from the uppermost level on the center line of the opening (Point A). The plumb line must be 1" (25mm) beyond the furthest protrusion. See Figure 11-3.
4. Clearly mark the tip of the plumb bob on the first floor. Point B is the center point of the carriage at the lower level. See Figure 11-4.

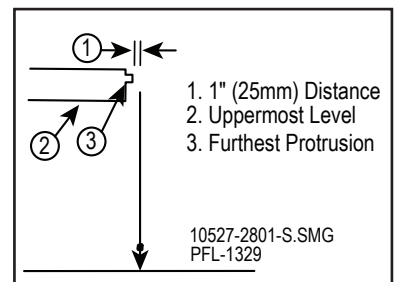

Floor-to-Floor Alignment Figure 11-3

NOTICE

All protrusions from the floor, wall, or other areas must be removed. Plumb lines must be positioned 1" (25mm) beyond the furthest protrusion or the carriage will not move beyond the protrusion after installation. The floor may need to be extended to get the proper distance from the floor to the carriage.

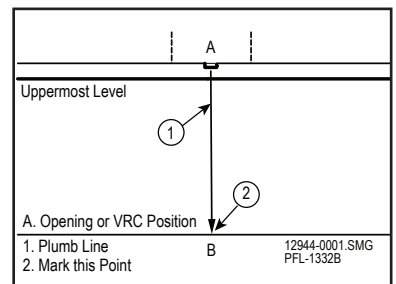

Mark Lower Floor Figure 11-4

**Mark Alignment
(continued)**

5. Drop two plumb lines from the uppermost level roughly 2' (1219mm) on each side of the center line. The plumb line must be 1" (25mm) beyond the furthest protrusion. See Figure 11-5.
6. Locate the three marks on the first floor. Snap a chalk line between C and D. See Figure 11-6.

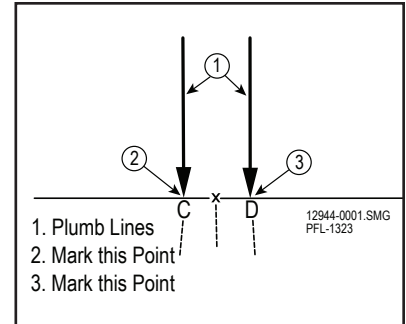

Align Floor-to-Floor Figure 11-5

Position the Carriage

1. Install a white ultra-high molecular weight (UHMW) block under the carriage, one (1) on each of the four (4) corners. See Figure 11-7.
2. Align the edge of the carriage on the snap line.
3. Align the center of the effective carriage deck to the center line floor mark. See Figure 11-6 and Figure 11-8.
4. Shim the underside of the carriage deck, if necessary, when a pit is present. The carriage deck should be the same level as the first floor level landing.
5. Temporarily secure the carriage from moving by welding the carriage to the building structure, welding temporary anchors, or welding side tabs.

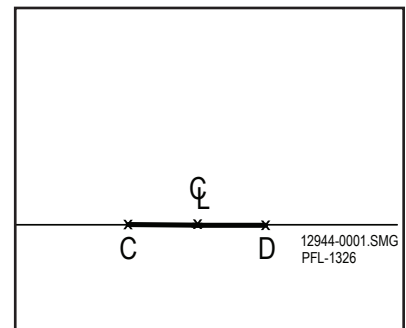

Align Lower Floor Figure 11-6

NOTE *If the carriage goes through a floor or shaftway, position the carriage after the backframe has been assembled, raised into place, and temporarily braced.*

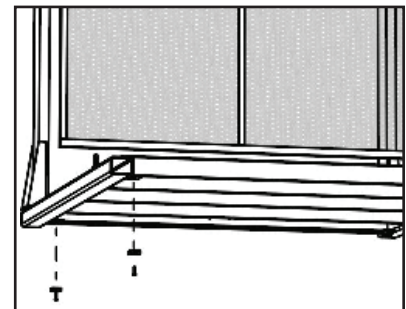

Attach UHMW Pads Figure 11-7

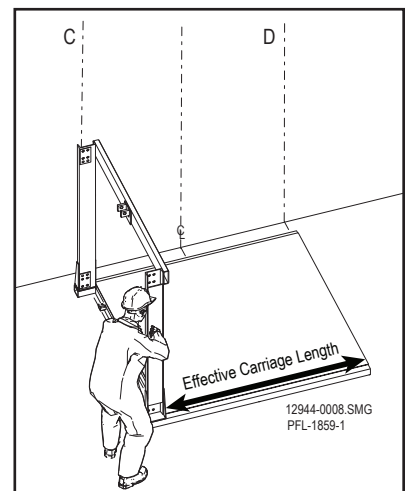

Place Carriage Figure 11-8



Before You Begin

Read this entire manual.

Before starting the installation, verify the job site dimensions and the dimensions of the delivered materials against the PFlow Industries, Inc. General Arrangement (GA) drawing. If the site conditions or the delivered materials do not match the GA drawing, please consult the PFlow Industries, Inc. Customer Support Department.

Before assembling any VRC components, review Section 13 for approved bracing guidelines.



Falling column hazard! The installation of this equipment requires a qualified installer with extensive knowledge and experience on how to rig, erect, and support structural steel.

NOTICE

A qualified person is defined as a person who, by possession of a recognized degree or certificate of professional standing, or by extensive knowledge, training, and experience, has successfully demonstrated his/her ability to solve problems relating to the subject matter and work.

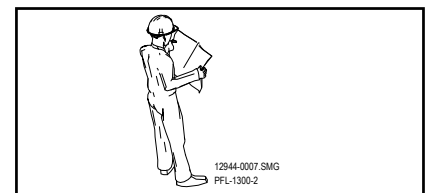

Verify Dimensions Figure 12-1

Purpose

The Vertical Reciprocating Conveyor (VRC) is designed for the movement of materials only, up to its rated capacity, from one level to the next level.

This section describes the installation of the backframe, wheelblocks, and carriage.

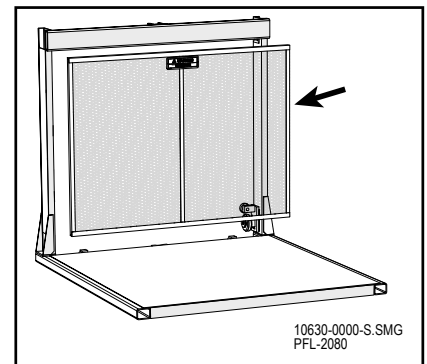

Remove Back Panel Figure 12-2

Remove the Back Panel

Remove the back panel from the carriage to allow easy access to the backframe. See Figure 12-2.

Review the GA Drawing for Backframe Placement

Refer to the PFlow Industries, Inc. General Arrangement (GA) drawing to confirm the correct orientation of the backframe, overall backframe dimension, and the base plate to pit dimension. Contact the PFlow Industries, Inc. Customer Support Department immediately concerning any discrepancies. See Figure 12-3.

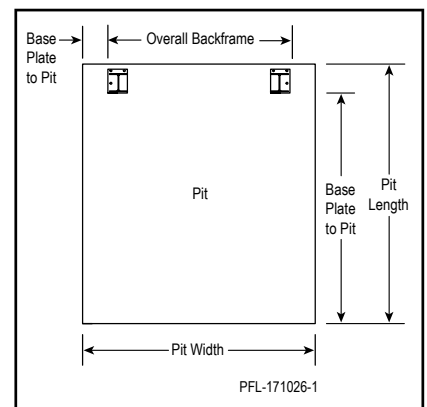

Verify Backframe Placement Figure 12-3

Spliced Backframe Guidelines

This VRC may have a spliced backframe. These instructions are for standard backframes. For other types of backframes, see job specific drawings at the end of the installation manual.

If the spliced pieces of the backframe are not assembled properly, the carriage will not travel smoothly along the full length of the columns.

NOTICE If there are more than three spliced pieces per backframe, see Figure 12-4 to determine placement of the spliced pieces.

NOTE Assembly is usually done vertically. It may be possible to fully assemble and weld the backframe pieces on the ground. However, it may not be possible to erect the full length spliced backframe.



Assemble the Spliced Backframe

DANGER

Falling column hazard! Properly support and temporarily brace the columns during spliced column assembly. The alignment bolts are used only to align the sections of the columns prior to welding. The alignment bolts are not strong enough to support the columns.

1. Match the spliced pieces of the backframe. See Figure 12-4 and Figure 12-5.
2. Remove the alignment bolts, lock washers, and nuts from the alignment tubes.
3. Insert the alignment bolt into the two (2) matching alignment tubes. See Figure 12-5.

NOTICE The alignment bolts are designed to fit tightly into the alignment tubes. You may need to tap the bolt into the tube with a hammer. Take care not to damage the threads.

4. Add a lock washer and nut to the alignment bolt and tighten.
5. If assembling the backframe in the upright position, temporarily brace all sections of the backframe.
6. Continue to bolt the remaining spliced backframe pieces together.
7. Remove the bolt, lock washer, and nut from the horizontal supports of the backframe. See Figure 12-6.
8. Attach the vertical angle support with the same bolts, lock washers, and nuts from step 7 and tighten firmly. See Figure 12-6.

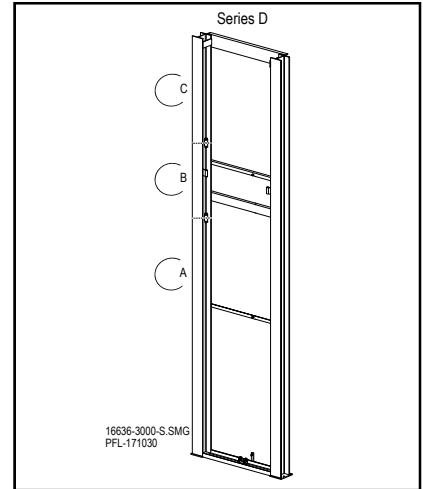

Backframe Spliced Sections
 Figure 12-4

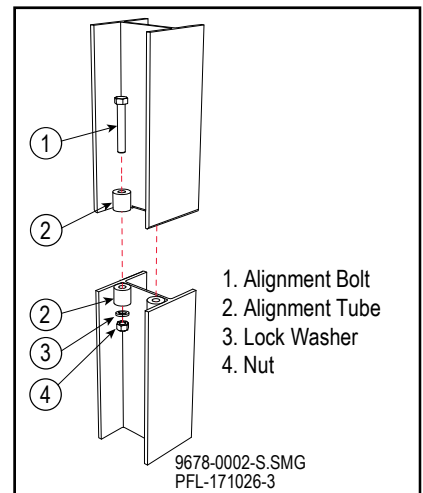

Assemble Spliced Backframes
 Figure 12-5

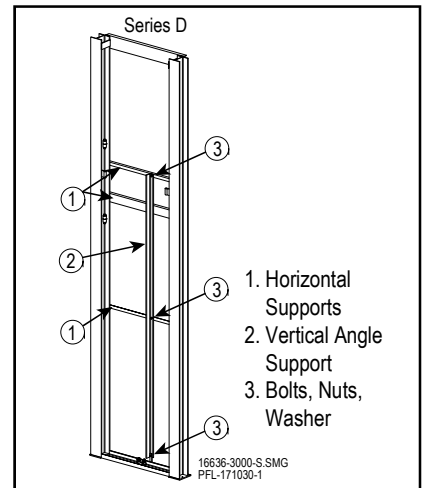

Attach Center Support
 Figure 12-6

Align the Spliced Backframe

Proper alignment is critical to the installation and operation of the VRC. The backframe is to be aligned from two directions and will need two (2) strings. See Figure 12-7.

1. Attach two (2) strings from the top to the bottom of the backframe, perpendicular to each other. Make sure both strings are taut.
2. Keep the same distance at all attachment points.
3. Measure between the string and the face of the column web at multiple points along the length of the backframe.
4. Maintain an equal distance between the string and the face of the column web down all backframe sections. Correct any discrepancies.

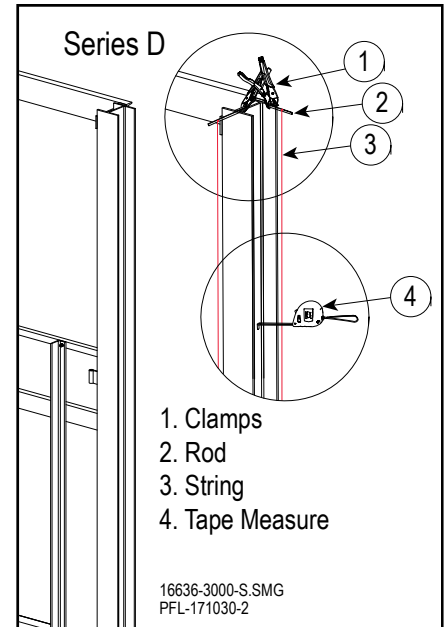

Spliced Column Alignment
Figure 12-7



Tack Weld the Spliced Backframe

Welding must be completed according to the standards and guidelines of the latest edition of AWS D1.1.

Weld filler material must be a minimum of E60xx.

NOTICE

To avoid column twist, avoid excessive heat while welding. Weld in a manner to allow the heat to dissipate.

Spliced Backframe Finish Welding Details

1. Finish weld all splice joints per the welding details shown in Figure 12-8.
2. Grind the welded area flat and smooth on the left and right surfaces of the backframe to allow the wheelblock enough clearance for vertical carriage travel.
3. Clean and clear any weld splatter from the inside of the column surfaces.
4. Clean and paint all welded areas.

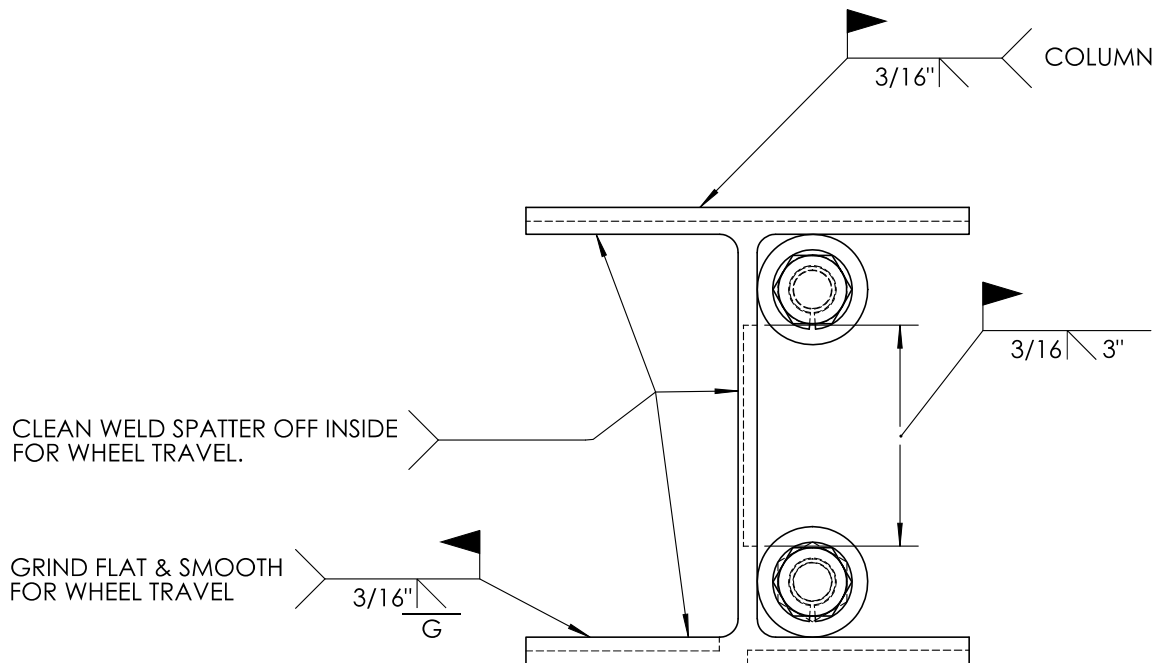

CLEAN WELD SPATTER OFF INSIDE FOR WHEEL TRAVEL.

GRIND FLAT & SMOOTH FOR WHEEL TRAVEL

▲ Field Weld Symbol

> Process or Other Reference Note

∟ Bevel

Field Welding For Column Splice Series D

9678-0002-S
 PFL-171026-5

Welding Notes
 Figure 12-8



Raise and Secure the Backframe

DANGER

Falling column hazard! Properly support the backframe during installation. Do not assume that the bolted connection on the carriage upright and the wheelblocks will prevent the backframe from falling.

1. Prepare to raise the backframe into position.
2. Review the weight of the backframe to confirm that the pick point will withstand the weight.
3. Use a suitable hoisting system that complies with local regulations.
4. Put a sling around the backframe using proper rigging techniques and attach the lifting device.
5. Carefully and slowly lift the backframe to an upright position.
6. Move the backframe into position and secure the backframe. See Figure 12-9.
7. Make sure the backframe is secure and cannot fall until permanent bracing is installed.

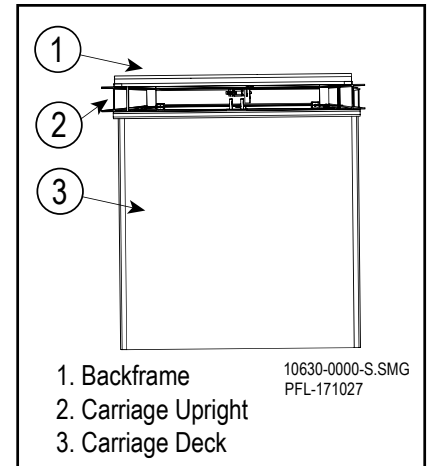

*Align Backframe
 Figure 12-9*



**Prepare the
Wheelblocks**

1. Remove the four (4) hex head screws, lock washers, and washers from each wheelblock. See Figure 12-10.
2. Review the wheelblock orientation diagram before installing the wheelblocks. See Figure 12-11.

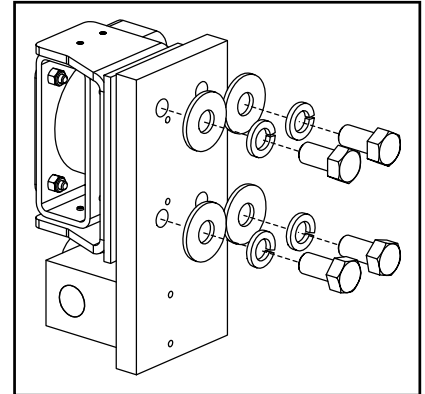

Remove Hex Head Screws
Figure 12-10

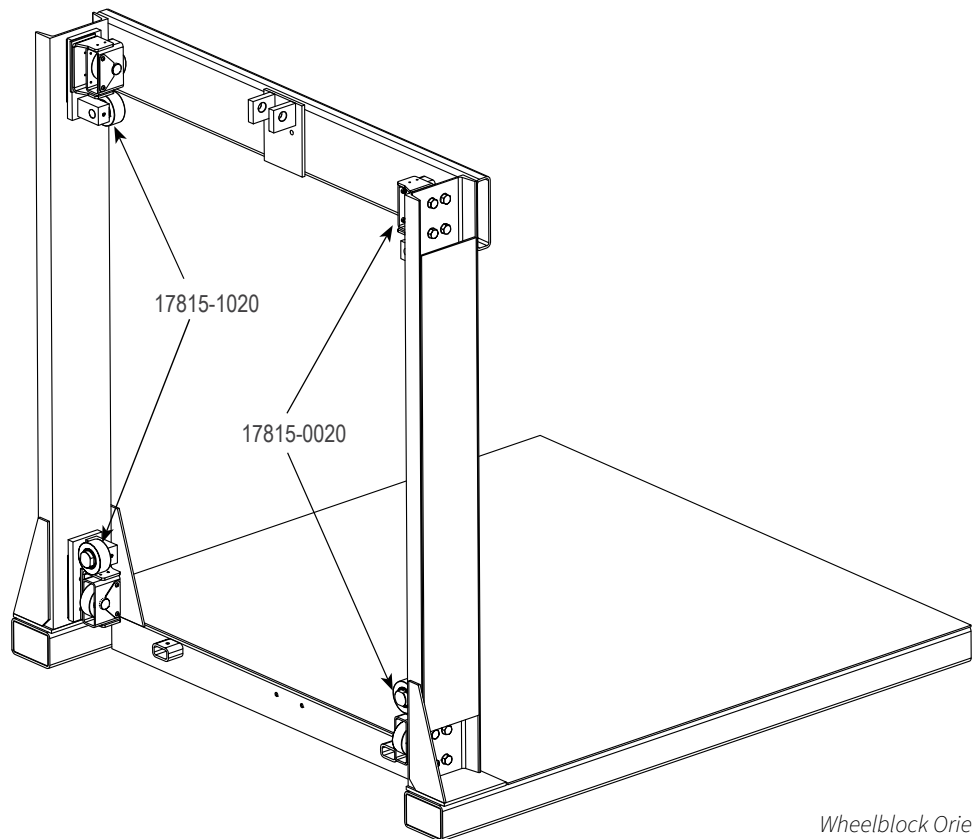

Wheelblock Orientation
Figure 12-11



CAUTION



Lifting hazard! Components and accessories may be heavy. Use the appropriate lifting apparatus or get help when moving or lifting. Installation of the twin roller guide wheelblock requires two (2) people to properly position the wheelblock.

Attach the Lower Wheelblocks

Two (2) people are required for this procedure.

1. Wrap a rope through the frame of the wheel on the lower wheelblock. See Figure 12-12.
2. With the wheel facing toward the backframe column and the guide roller facing up, maneuver the lower wheelblock in between the backframe and the carriage upright.
3. Align the holes in the back of the wheelblock with the holes in the carriage upright.
4. Insert the four (4) hex head bolts, lock washers, and washers through the holes in the carriage upright and into the wheelblock. **A minimum thread engagement of 5/8" (16mm) is required.** See Figure 12-13.
5. Tighten all bolts.

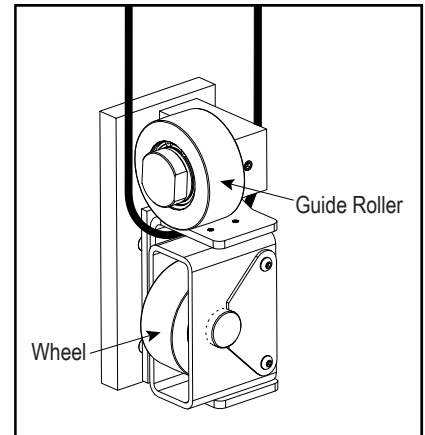

Rope Placement, Lower Wheelblock
 Figure 12-12

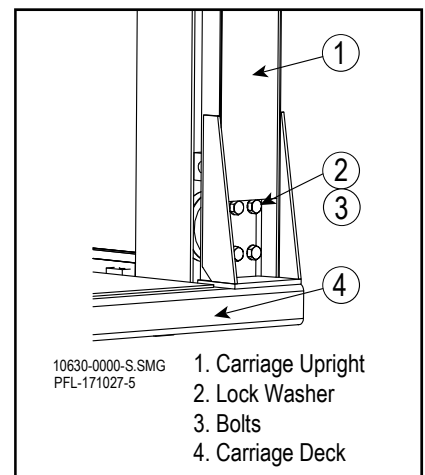

10630-0000-S.SMG
 PFL-171027-5

1. Carriage Upright
2. Lock Washer
3. Bolts
4. Carriage Deck

Lower Wheelblock Mounting
 Figure 12-13



CAUTION



Lifting hazard! Components and accessories may be heavy. Use the appropriate lifting apparatus or get help when moving or lifting. Installation of the twin roller guide wheelblock requires two (2) people to properly position the wheelblock.

Attach the Upper Wheelblocks

Two (2) people are required for this procedure.

1. Wrap a rope through the frame of the wheel on the upper wheelblock. See Figure 12-14.
2. With the wheel facing toward the backframe column and the guide roller facing down, maneuver the upper wheelblock in between the backframe and the carriage upright.
3. Align the holes in the back of the wheelblock with the holes in the carriage upright.
4. Insert the four (4) hex head bolts, lock washers, and washers through the holes in the carriage upright and into the wheelblock. **A minimum thread engagement of 5/8" (16mm) is required.** See Figure 12-15.
5. Tighten all bolts.

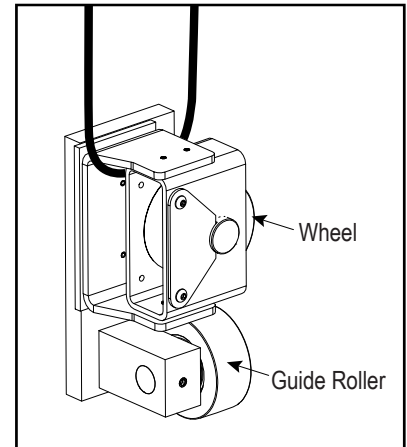

Rope Placement, Upper Wheelblock
 Figure 12-14

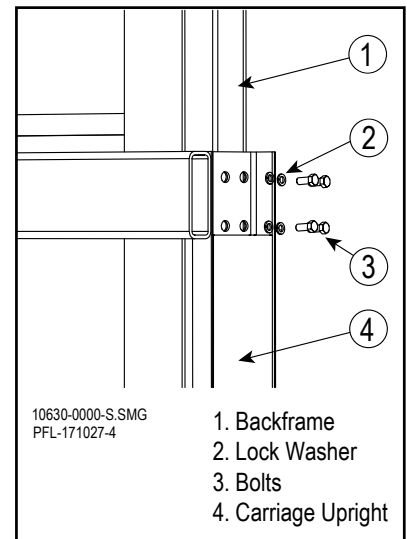

10630-0000-S.SMG
 PFL-171027-4

1. Backframe
2. Lock Washer
3. Bolts
4. Carriage Upright

Upper Wheelblock Mounting
 Figure 12-15

Review the Backframe Columns for Plumb

Proper alignment is critical to the installation and operation of the VRC. The backframe is to be aligned from two directions and will need two (2) strings. See Figure 12-16.

1. Attach two (2) strings from the top to the bottom of the backframe, perpendicular to each other. Make sure both strings are taut.
2. Keep the same distance at all attachment points.
3. Measure between the string and the face of the column web at multiple points along the length of the backframe.
4. Maintain an equal distance between the string and the face of the column web down all backframe sections. Correct any discrepancies.
5. Make sure both columns of the backframe are plumb in both directions. See Figure 12-17.

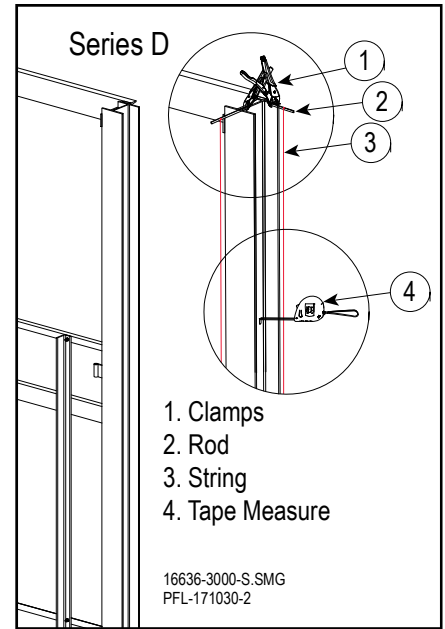

Column Alignment
 Figure 12-16

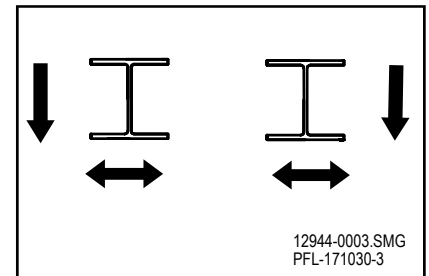

Review Columns for Plumb
 Figure 12-17

Brace the Backframe

NOTICE

1. Review the Bracing Instructions in Section 13 of this installation manual.

Bracing must resist all dynamic operational loads. The General Arrangement (GA) drawing states the static lateral load that the bracing must support. Each side of the backframe requires bracing in both front to back and side to side directions.

2. A job specific bracing drawing may be provided. Verify drawing details prior to beginning field bracing work.
3. Make sure the carriage deck is the same level as the floor.
4. Recheck the backframe spacing dimension and plumb.
5. Tack weld the upper floor-to-backframe braces to the face of the floor or mezzanine. See Figure 12-18.
6. Verify the proper anchor size and type for the job site. Special conditions (e.g., seismic site location) require proper anchoring and bracing methods are used.
7. If the columns are plumb, lag the backframe base plates to the floor according to local, state, or country codes especially in seismic zones. PFlow Industries, Inc. recommends 3/8" x 4" (9,5mm x 102mm) long wedge style anchors.
8. Fully field weld the backframe braces to the face of the upper floor or mezzanine.
9. Add side bracing and fully weld.

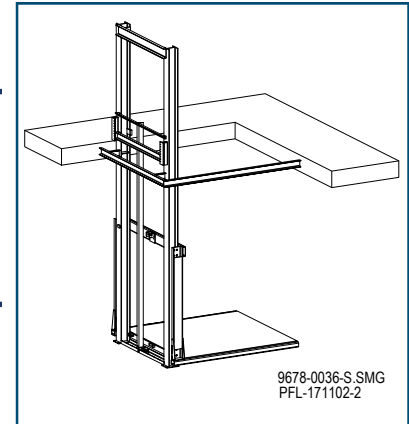

Backframe Bracing
Figure 12-18



Install the Hydraulic Cylinder

For proper installation, from the back of the VRC, the supply port plug is on the right side. Make sure this is correct before proceeding.

1. Mount the bottom of the cylinder rod to the backframe weldment with a split collar clamp on each side. Tighten the setscrews. See Figure 12-19.
2. Mount the top of the cylinder rod to the carriage clevis with the 1" (25mm) diameter cylinder pin, washer, and cotter pin. See Figure 12-20.
3. Mount the Anti-Twist UHMW (slide) block to the tapped block on the cylinder with 5/16 x 2-1/2" long bolts, washers and lock washers. See Figure 12-21.
4. Make sure the Anti-Twist UHMW block is not binding on the Anti-Twist angle.

NOTE *The UHMW (slide) block can be flipped 180 degrees if a better fit is required.*

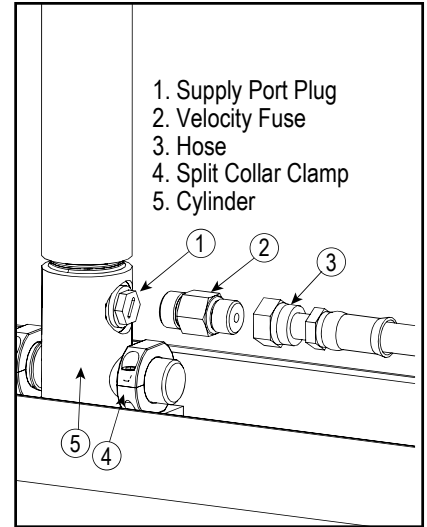

Install Bottom of Cylinder
 Figure 12-19

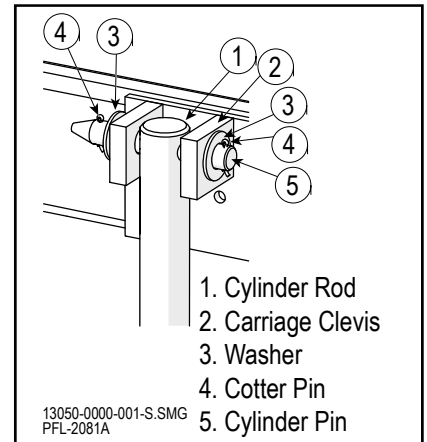

Install Top of Cylinder
 Figure 12-20

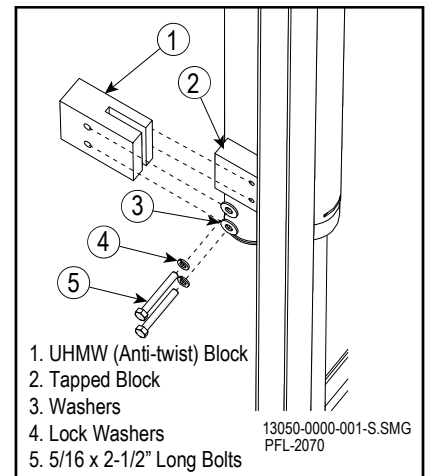

Install Anti-Twist Kit
 Figure 12-21





Before You Begin

Read this entire manual. Verify the job site dimensions against the PFlow Industries, Inc. General Arrangement (GA) drawing before starting the installation. If the site conditions do not match the GA drawing, please consult the PFlow Industries, Inc. Customer Support Department.



⚠ DANGER

Falling column hazard! The installation of this equipment requires a qualified installer with extensive knowledge and experience on how to rig, erect, and support structural steel. Be sure to properly support the columns, posts, and panels during installation. The carriage and wheelblocks cannot prevent the columns from falling. Do not depend on the base plates or feet to prevent the columns, posts, and panels from falling.

NOTICE

A qualified person is defined as a person who, by possession of a recognized degree or certificate of professional standing, or by extensive knowledge, training, and experience, has successfully demonstrated his/her ability to solve problems relating to the subject matter and work.

⚠ CAUTION



Lifting hazard! Components and accessories may be heavy. Use the appropriate lifting apparatus or get help when moving or lifting.

Required Anchoring and Bracing Guidelines

Anchoring and bracing of the Vertical Reciprocating Conveyor (VRC) is **required**. Illustrations in this section are to be used for reference only. Job site conditions may require a different alternative to those PFlow Industries suggests in this document. A job specific bracing drawing may be provided. Verify drawing details prior to beginning any field bracing work. Before any final field welding is done, verify that the VRC columns and carriage are aligned correctly.

All field welding must conform to the latest edition of AWS D1.1. The weld filler material is to be a minimum of E60xx.

- Fully weld horizontal floor braces.
- Fully weld support bracing at upper levels (unless shown otherwise).
- Fully weld all VRC connections and drive base mounting angles.

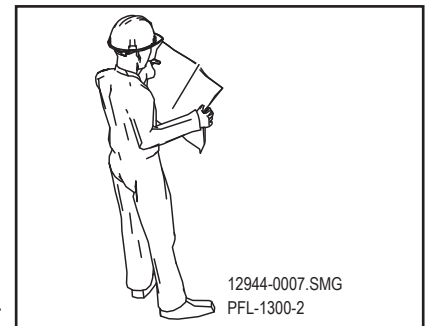

12944-0007.SMG
 PFL-1300-2

Review GA Drawing
 Figure 13-1



Side to Side and Front to Back Bracing

Side to side and front to back bracing of the Vertical Reciprocating Conveyor (VRC) is required. Bracing the VRC and enclosures is the responsibility of the installer.

It is the customer’s responsibility to make sure that the job site conditions have a structure with enough strength to be used for bracing in order to withstand the forces of weight and gravity.

NOTE *If PFlow Industries, Inc. prepared seismic bracing materials, the bracing requirements and the General Arrangement (GA) drawing are provided in the shipping packet.*

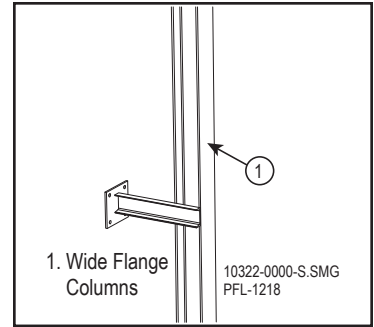

Bracing Columns
 Figure 13-2

Bracing Supplies

Typically, for a two-level VRC, PFlow Industries, Inc. supplies:

- (2) 10' (3,048 m) lengths of 4" (102mm) channel or
- (2) 10' (3,048 m) lengths of wall tube
 2" x 4" x 1/4" (51mm x 102mm x 6mm)
- (2) 10' (3,048 m) lengths of angle per supplied gate
 1-1/2" x 1-1/2" x 1/8" (38mm x 38mm x 3mm)
- (2) to (4) mounting plates

Each additional level is supplied with the following:

- (1) 10' (3,048 m) length of channel or
- (1) 10' (3,048 m) length of wall tube
 2" x 4" x 1/4" (51mm x 102mm x 6mm)
- (1) 10' (3,048 m) length of angle per supplied gate
 1-1/2" x 1-1/2" x 1/8" (38mm x 38mm x 3mm)
- (2) mounting plates

NOTICE PFlow Industries, Inc. does not supply anchor bolts nor guarantee that the above material is sufficient for the application. It is the installer’s responsibility to verify the information included in the shipping packet prior to commencing work.

Anchoring Guidelines

<p>12944-0009.SMG PFL-1235</p>	<p>12944-0009.SMG PFL-1231</p>
<p>Using a tie plate Figure 13-3</p>	<p>Welding to a curb angle Figure 13-4</p>
<p>12944-0009.SMG PFL-1238</p>	<p>12944-0009.SMG PFL-1240</p>
<p>Anchoring to a wood floor - through bolting Figure 13-5</p>	<p>Anchoring to a CMU wall with backing plates Figure 13-6</p>
<p>12944-0009.SMG PFL-1241</p>	<p>12944-0009.SMG PFL-1239</p>
<p>Anchoring to a wooden floor (preferred method) Figure 13-7</p>	<p>Anchoring to a wooden floor (not recommended) Figure 13-8</p>
<p>12944-0009.SMG PFL-1227</p>	<p>12944-0009.SMG PFL-1232</p> <p>12944-0009.SMG PFL-1234</p>
<p>Anchoring to CMU wall (not recommended) Figure 13-9</p>	<p>Anchoring mounting plate to solid floor Figure 13-10</p>

Bracing Guidelines

The following guidelines illustrate acceptable methods of attaching bracing to a building.



! DANGER

Falling column hazard! To avoid serious personal injury or death, do not lift the carriage or load the carriage until the VRC bracing is adequately sized and welded.

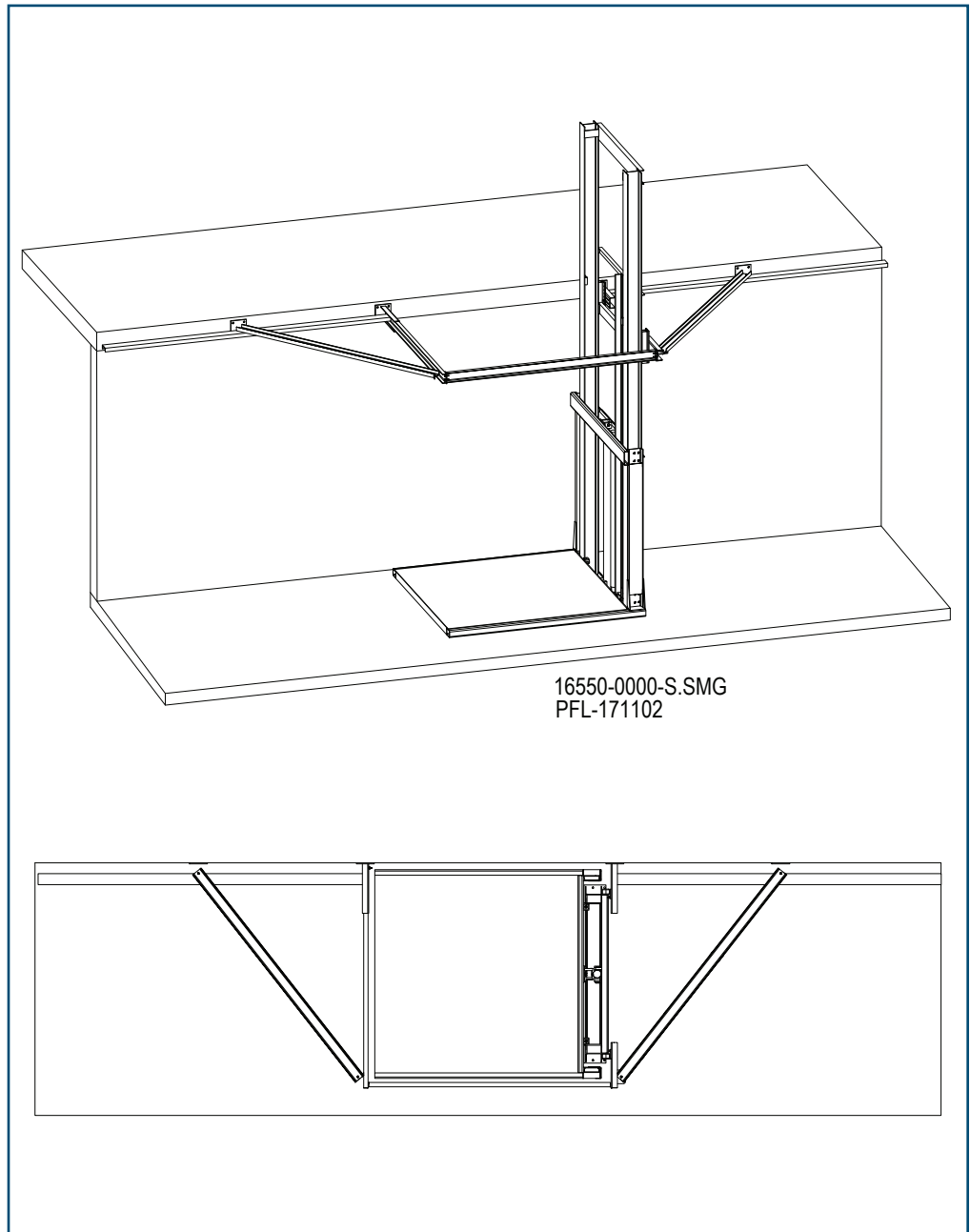

*On the Side of a Mezzanine
Figure 13-11*



Bracing Guidelines

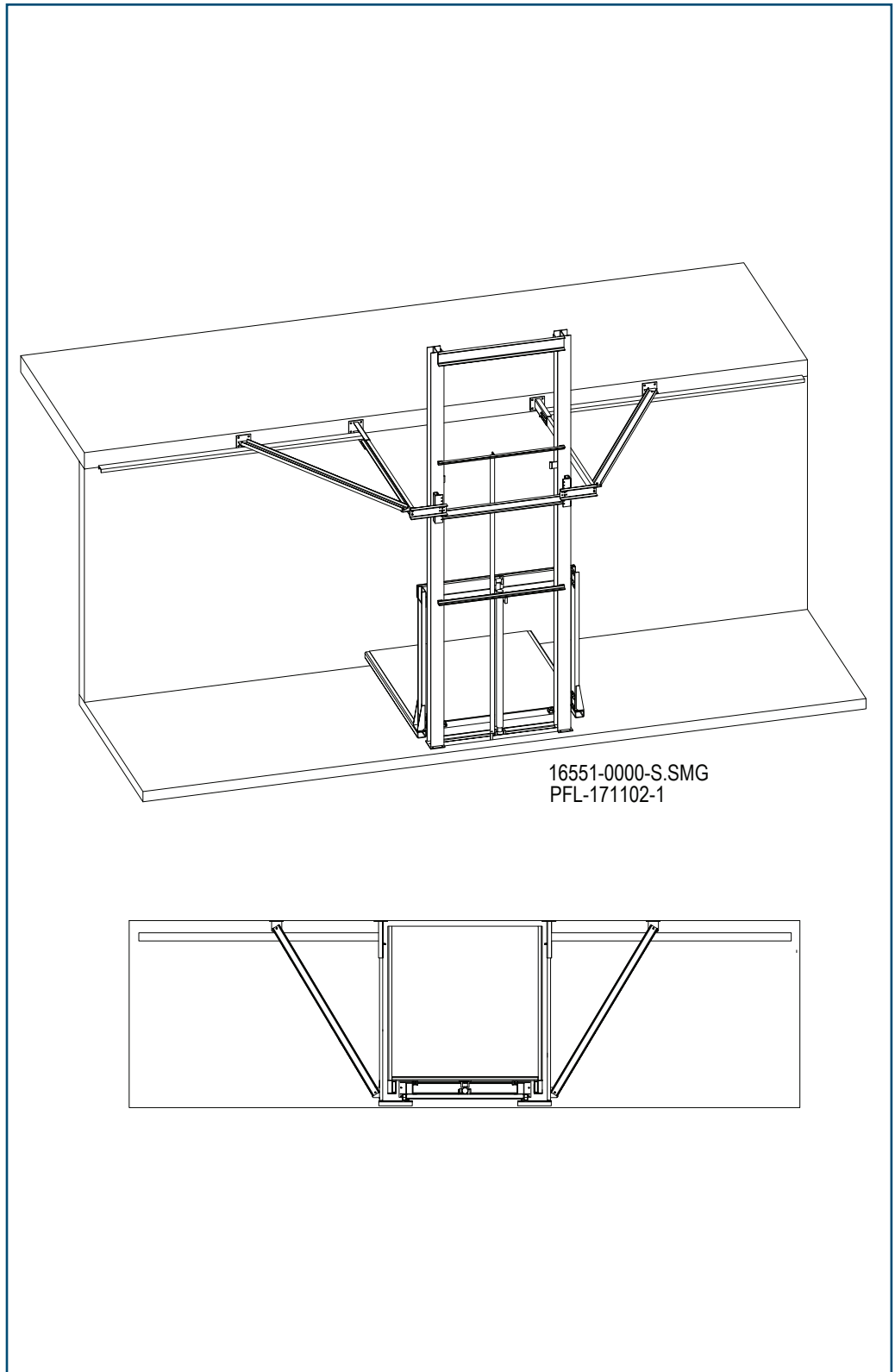

16551-0000-S.SMG
PFL-171102-1

Facing a Mezzanine
Figure 13-12



Bracing Guidelines

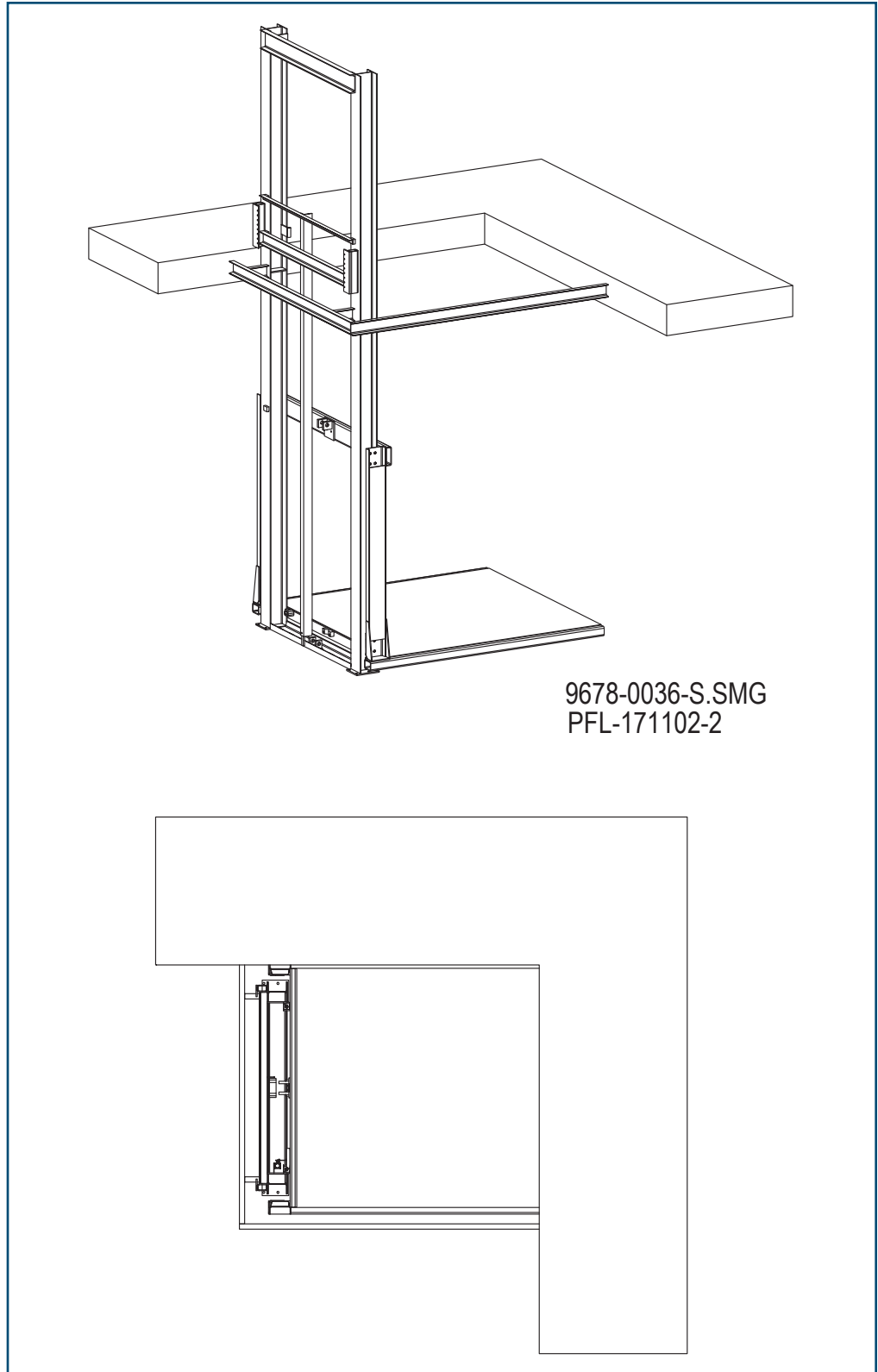

9678-0036-S.SMG
PFL-171102-2

Through a Cutout or Oversized Hole
Figure 13-13



Bracing Guidelines

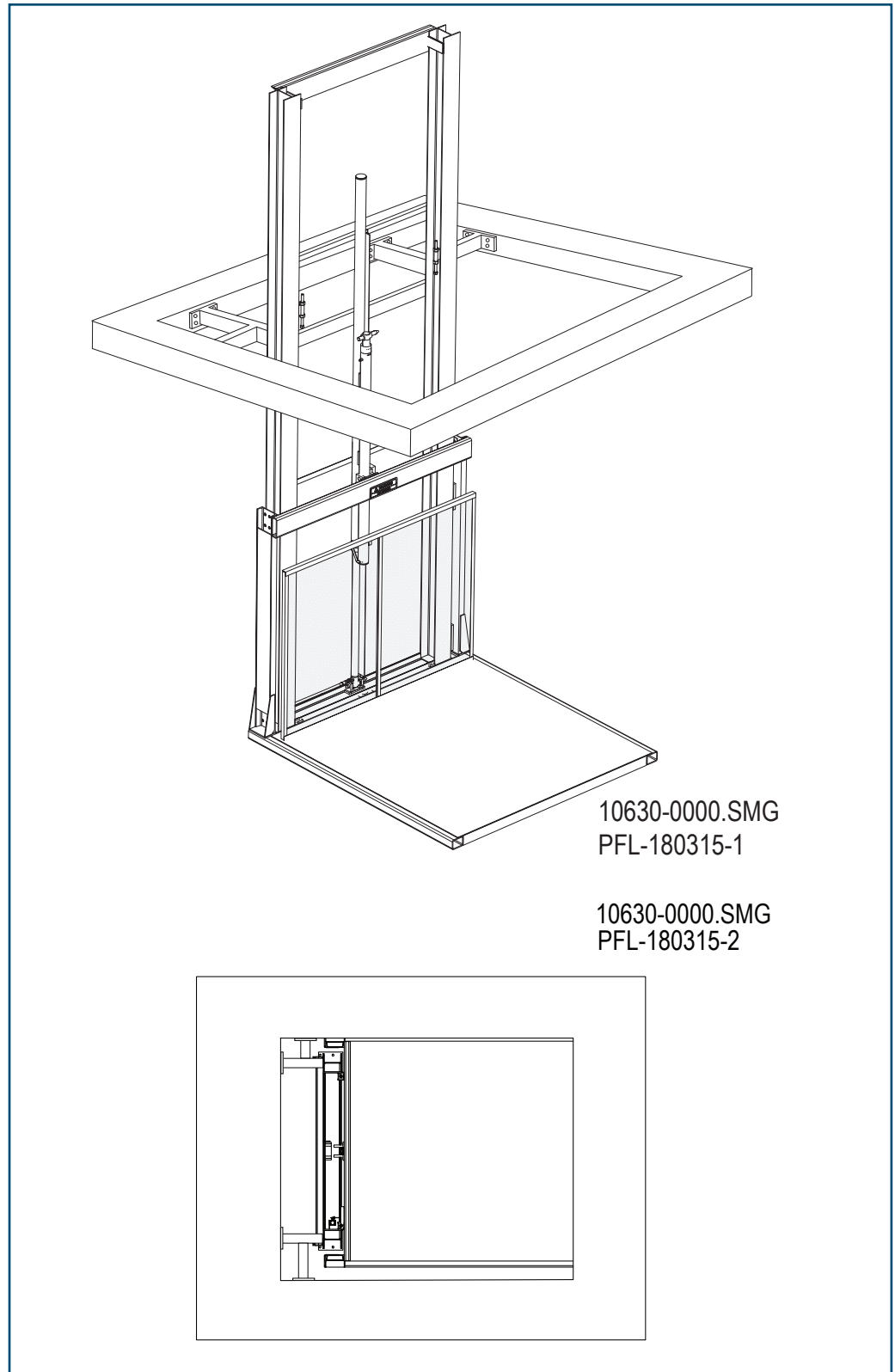

Through a Floor
Figure 13-14



Sliding Gates

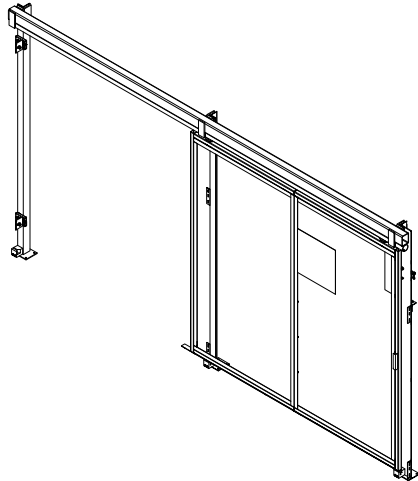

Figure 16-1
Sliding Gate, Single Panel

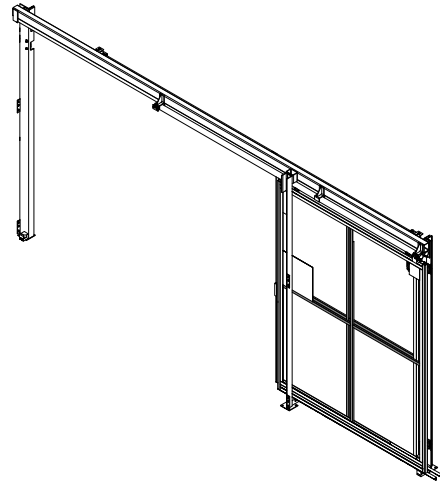

Figure 16-2
Sliding Gate, Single Panel, Pneumatic

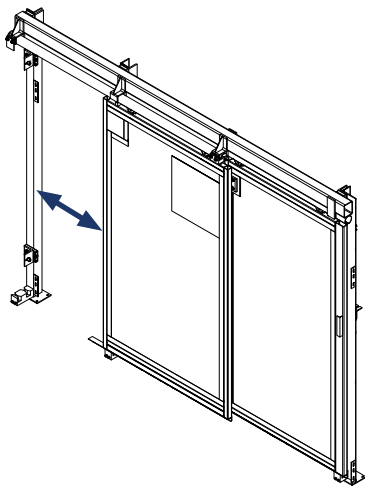

Figure 16-3
Sliding Gate, Bi-Panel

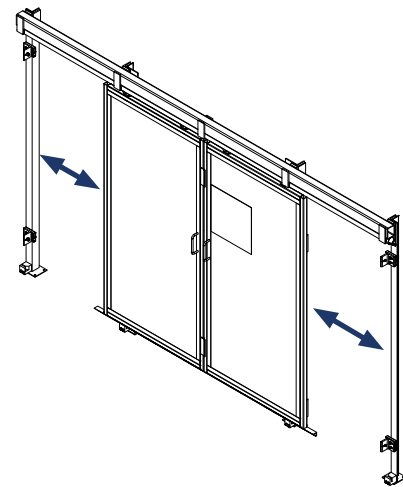

Figure 16-4
Sliding Gate, Bi-Parting

Swing Gates

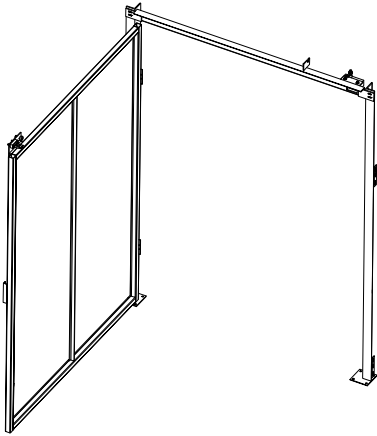

Figure 16-5
Swing Gate, Single Panel

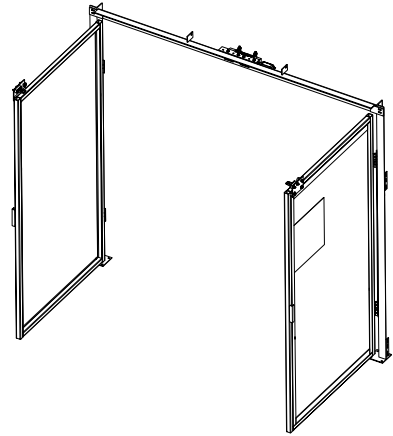

Figure 16-6
Swing Gate, Bi-Parting

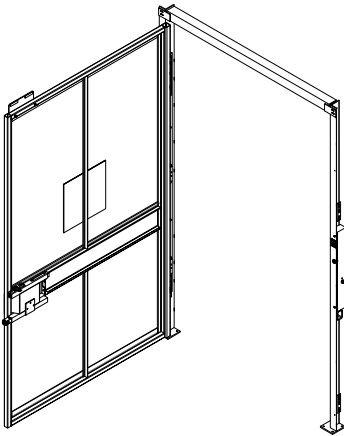

Figure 16-7
Swing Gate, Single Panel, Floor Level, Slide Latch

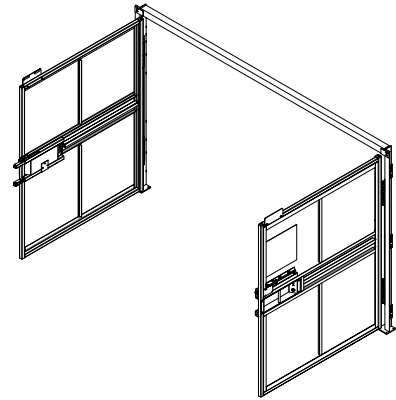

Figure 16-8
Swing Gate, Bi-Swing, Floor Level, Slide Latch

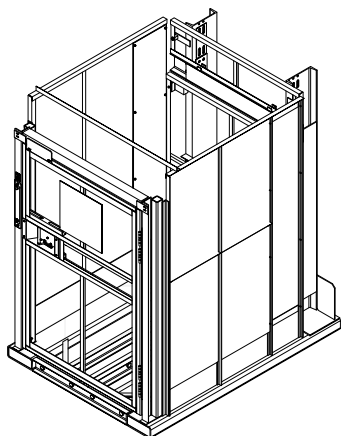

Figure 16-9
Swing Gate, Single Panel, Carriage Mounted, Slide Latch

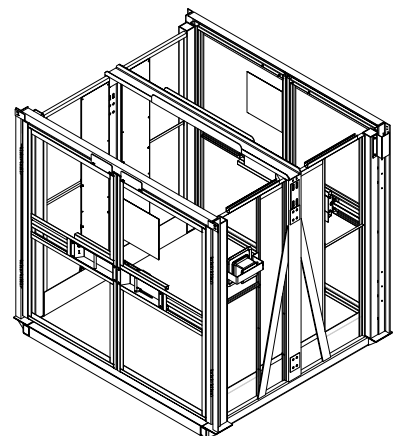

Figure 16-10
Swing Gate, Bi-Swing, Carriage Mounted, Slide Latch

Vertical Acting Gates

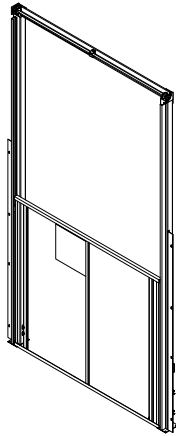

Figure 16-11
Vertical Acting Gate, Single Panel

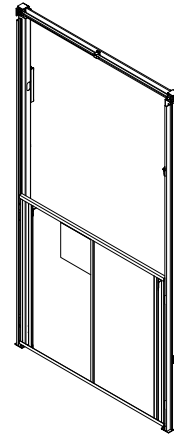

Figure 16-12
Vertical Acting Gate, Single Panel, Carriage Mounted

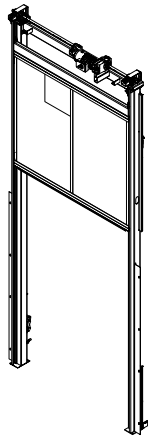

Figure 16-13
Vertical Acting Gate, Single Panel, Motorized

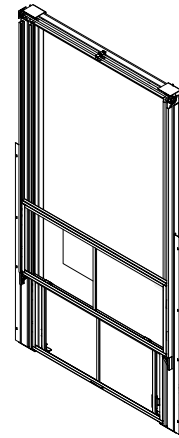

Figure 16-14
Vertical Acting Gate, Bi-Panel

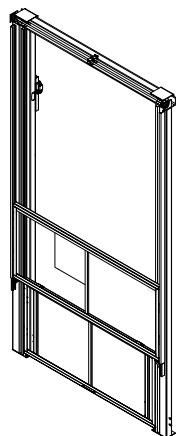

Figure 16-15
Vertical Acting Gate, Bi-Panel, Carriage Mounted

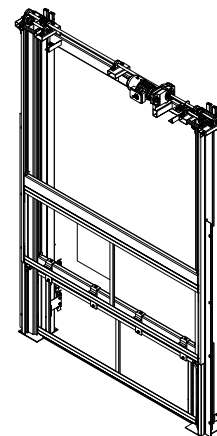

Figure 16-16
Vertical Acting Gate, Bi-Panel, Motorized



Installation Instructions

Figure No.	Gate Type	Installation Instructions
Sliding Gates		
Figure 16-1	Sliding Gate, Single Panel	15709-0005
Figure 16-2	Sliding Gate, Single Panel, Pneumatic	**
Figure 16-3	Sliding Gate, Bi-Panel (both panels slide in the same direction)	15709-0005
Figure 16-4	Sliding Gate, Bi-Parting (panels slide in opposite directions)	15709-0005
Swing Gates		
Figure 16-5	Swing Gate, Single Panel	15709-0005
Figure 16-6	Swing Gate, Bi-Parting	15709-0005
Figure 16-7	Swing Gate, Single Panel, Floor Level, Slide Latch	15709-0120
Figure 16-8	Swing Gate, Bi-Swing, Floor Level, Slide Latch	15709-0126
Figure 16-8	Swing Gate, Single Panel, Carriage Mounted, Slide Latch	**
Figure 16-10	Swing Gate, Bi-Swing, Carriage Mounted, Slide Latch	**
Vertical Acting Gates		
Figure 16-11	Vertical Acting Gate, Single Panel	15709-0156
Figure 16-12	Vertical Acting Gate, Single Panel, Carriage Mounted	15709-0157
Figure 16-13	Vertical Acting Gate, Single Panel, Motorized	15709-0133
Figure 16-14	Vertical Acting Gate, Bi-Panel	15709-0014
Figure 16-15	Vertical Acting Gate, Bi-Panel, Carriage Mounted	15709-0163
Figure 16-16	Vertical Acting Gate, Bi-Panel, Motorized	15709-0143

**Contact PFlow Industries, Inc. Customer Support Department

See job specific gate installation instructions included with your shipment. Gate installation instruction PDFs can also be found on our website at <https://www.pflow.com/knowledge-base>.





Before You Begin

Read this entire manual.

Before starting the installation, verify the job site dimensions and the dimensions of the delivered materials against the PFlow Industries, Inc. General Arrangement (GA) drawing. If the site conditions or the delivered materials do not match the GA drawing, please consult the PFlow Industries, Inc. Customer Support Department.

WARNING

- Falling equipment hazard! The installation, maintenance, or servicing of this equipment requires qualified personnel with extensive knowledge and experience on how to rig, erect, and support structural steel.
-  Lockout/tagout equipment before performing any adjustments or maintenance. If the equipment is not locked out, it could start unexpectedly and cause injury or damage. **Make sure all personnel are aware of the potential for stored energy to be present even after the power has been locked out.** Refer to ANSI Z244.1 and OSHA 29 CFR 1910.147 for minimum requirements for a lockout/tagout system. There may be additional national, state, or local requirements.
-  Falling hazard! Close all gates before the carriage is moved. Never leave the lift unattended with the gates in the open position. Never close gates when a person is on the carriage or within the fenced area.
- Make sure the gate is, and remains, secured to prevent unsafe use of the gate. Always lock the gate panel closed if the gate area is unattended.

NOTICE

A qualified person is defined as a person who, by possession of a recognized degree or certificate of professional standing, or by extensive knowledge, training, and experience, has successfully demonstrated his/her ability to solve problems relating to the subject matter and work.

The Purpose of the Gate Cable Interlock

The electromechanical interlock is a safety device used to mechanically prevent the gate from opening. When the carriage is at that level and the gate is open, the VRC should not operate. Replacement components are only available as shown on the next few pages. Some configurations may vary by application. One of five (5) different manufacturer's components may be used for this installation. See Figure 17-1.

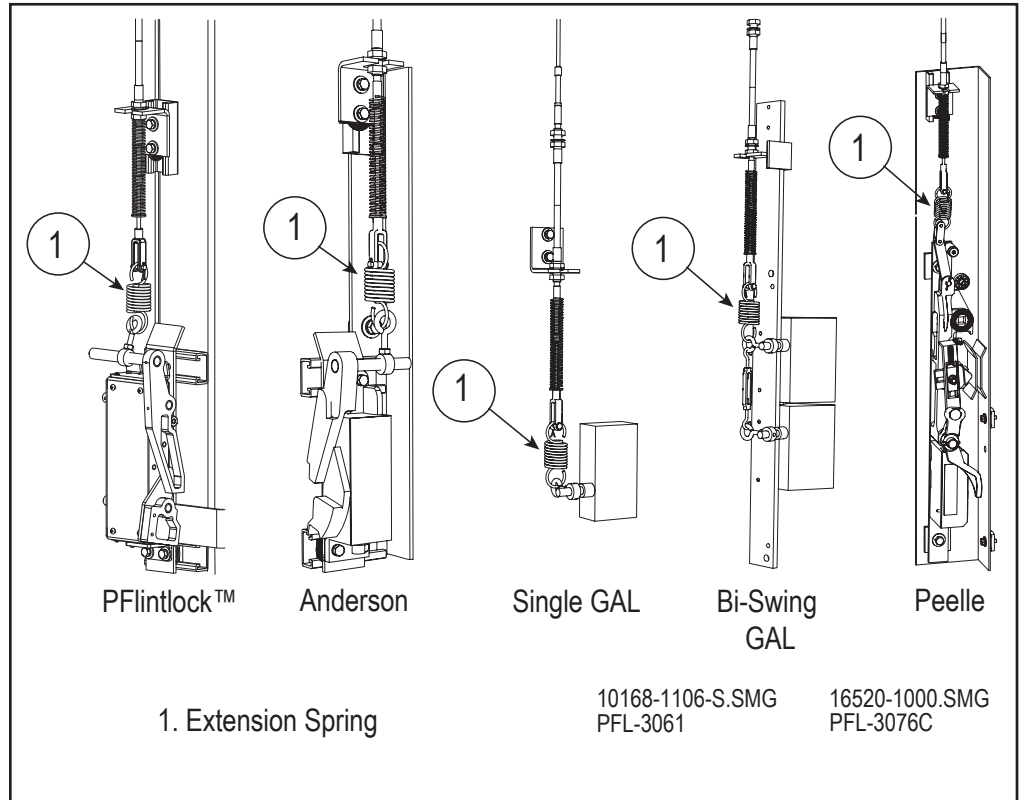

*Cable Interlocks
 Figure 17-1*

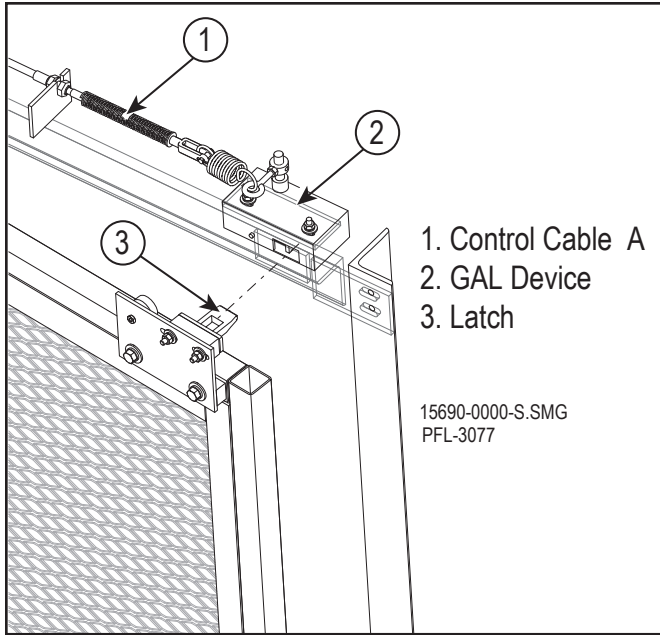

GAL Interlock on Single Panel Swing Gate
 Figure 17-2

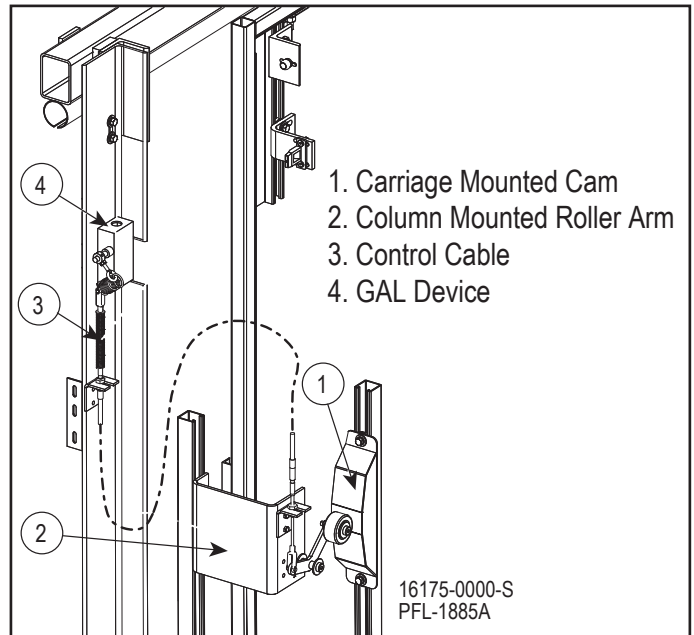

GAL Interlock on Sliding Gate
 Figure 17-3

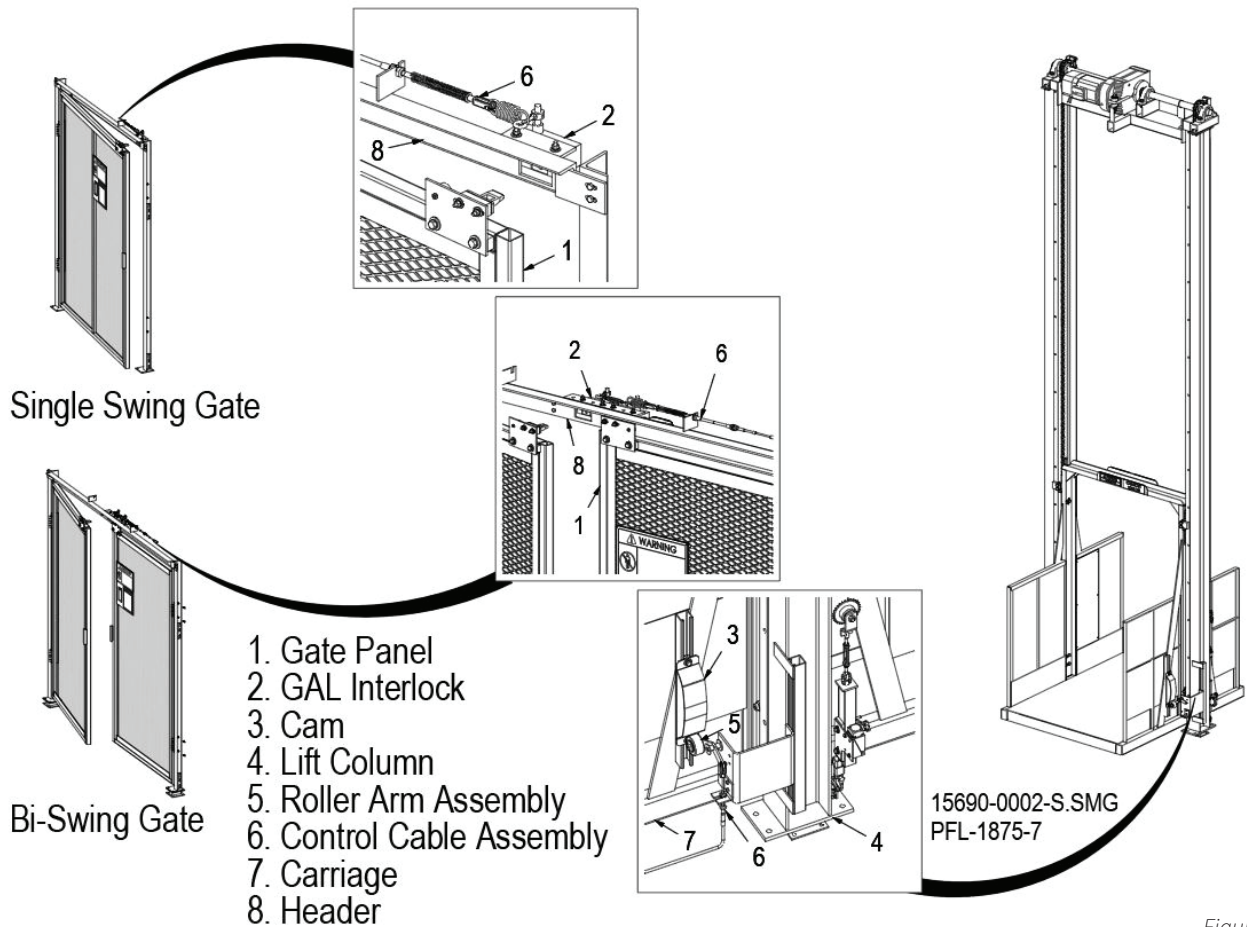

Figure 17-4

General Descriptions

The cable interlock consists of four (4) main items:

- Carriage Cam
- Column Mounted Roller Assembly
- Control Cable
- Gate Cable Interlock Assembly

Carriage Cam

The carriage cam is mounted on the carriage and positioned to activate the roller assembly. The roller must move freely on the inclined face of the carriage cam and allow the control cable to activate the interlock. See Figure 17-5.

Column Mounted Roller Assembly

The roller assembly is mounted on the VRC column. The roller assembly must be positioned to allow the roller to make contact with the carriage cam. See Figure 17-5.

Control Cable

The control cable is a utility cable with threaded stainless steel end rods. The cable has a maximum 2" (51mm) travel. When the control cable is pulled by the roller assembly as it moves along the carriage cam, the interlock locking arm opens. When the control cable is pushed by the roller assembly as it moves along the carriage cam, the interlock locking arm locks into position. See Figure 17-6.

Gate Cable Interlock Assembly

The gate cable interlock assembly is attached to the gate post. The travel of the cable is adjusted to permit the interlock to release the gate latch.

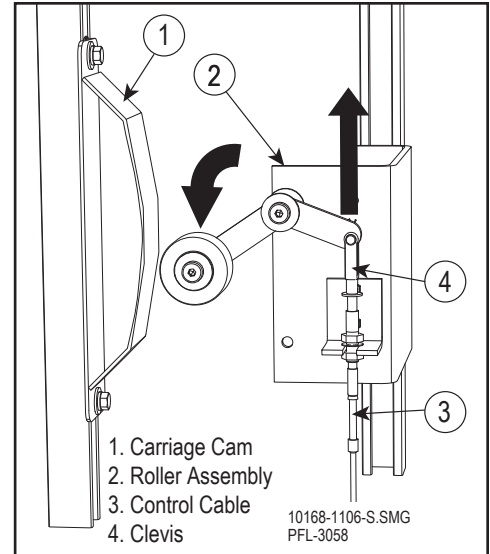

Roller Assembly Position
 Figure 17-5

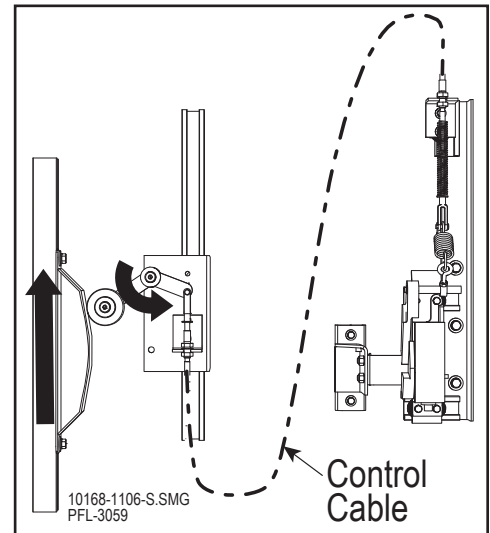

Control Cable Position
 Figure 17-6

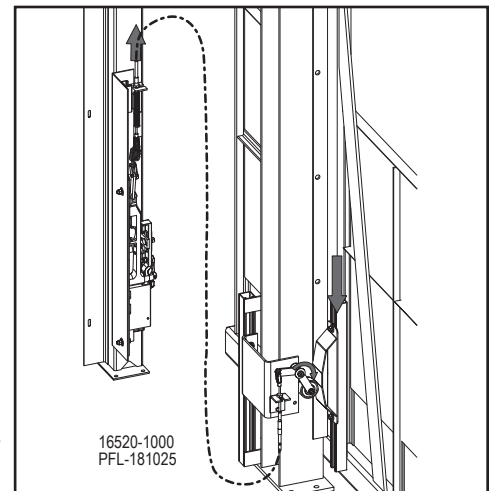

Pelle Interlock
 Figure 17-7

Peelle Terms

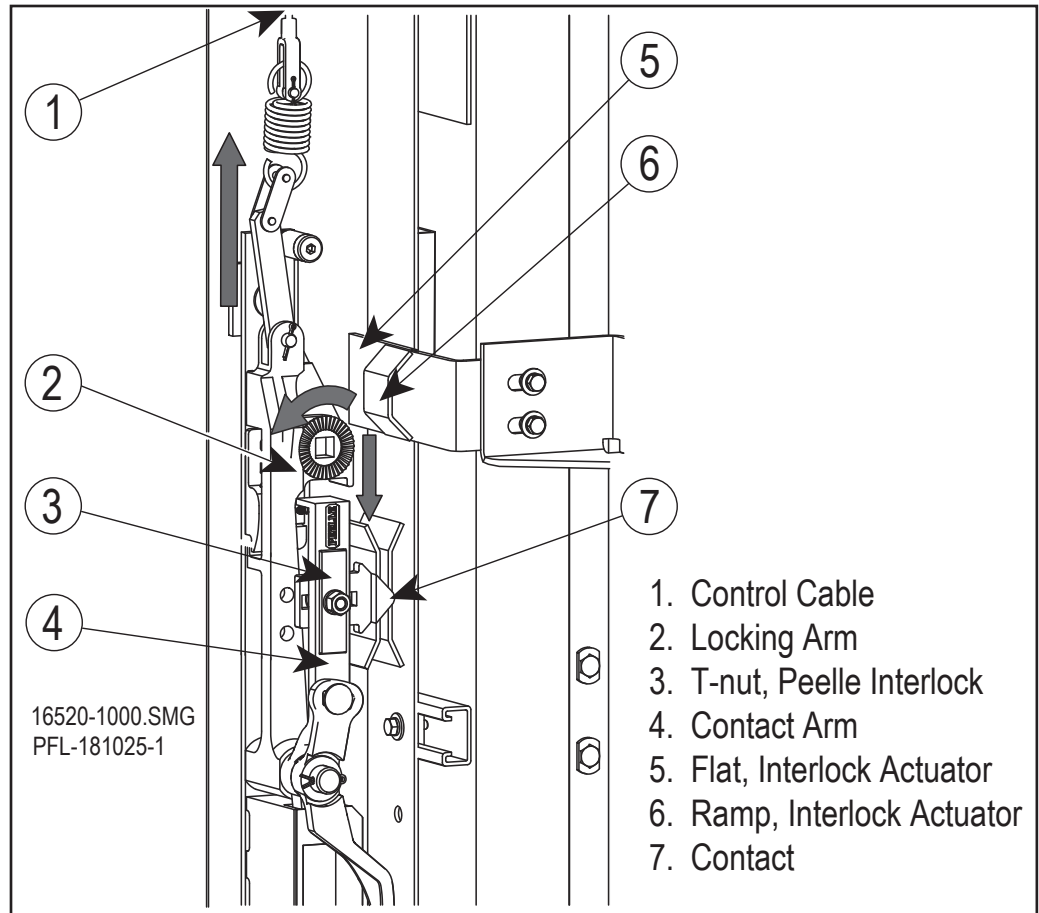

Peelle Interlock Open Position
 Figure 17-8

The Peelle interlock contact arm assembly and locking arm assembly operate and move independently from each other. See Figure 17-8.

The locking arm assembly captures the gate panel interlock actuator flat to mechanically lock the gate panel closed. See Figure 17-9.

The contact arm assembly is moved by the gate panel interlock actuator to open or close the interlock electrical contacts.

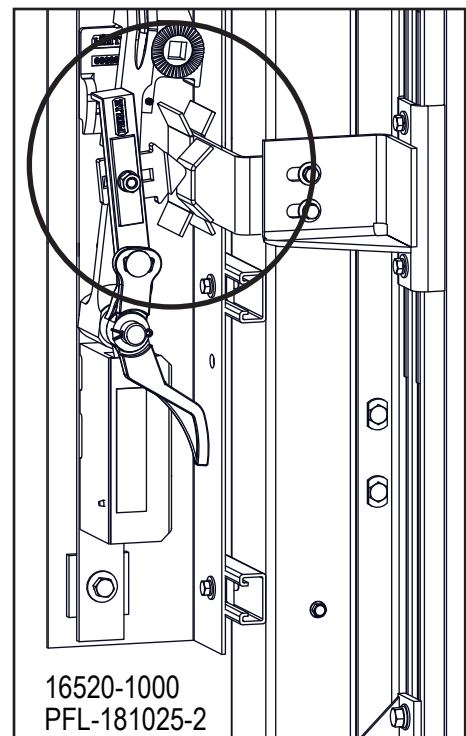

Peelle Interlock Closed Position
 Figure 17-9

! DANGER

- Control cables are designed to be non-repairable. If the control cable is damaged or worn out, the interlock may not operate properly. These issues could prevent the interlock from engaging and allow the gate panel to stay open while the carriage is moving from one level to another.
- Protect the control cables from physical damage (e.g., kinking, vibration, sharp bends). Maintain a minimum bend radius of 12" (305mm). The control cable may not operate properly if the control cable is bent sharper than the 12" (305mm) radius. This could prevent the interlock from engaging and allow the gate panel to stay open while the carriage is moving from one level to another.

! WARNING

- If the control cable is damaged or worn out, the interlock may not operate properly.
 - Protect the control cables from physical damage (e.g., kinking, vibration, sharp bends). Do not extend cable travel beyond 2" (51mm).
 - Route excess gate interlock cables as straight as possible and do not spool in coils tighter than 28" (711mm).
 - Protect the control cables from chemical damage (paint, solvents, oils, water or ice, dirt, other contaminants.)
 - Replace worn or damaged control cables. Do not attempt to lubricate or repair. Signs of wear include frayed ends, sudden decrease in usable travel, and moisture in the control cable.

Interlock Placement

When using 1-3/4" (44mm) width unistruts, the distance between the outside curve of the cam and the outside edge of the unistrut should be 5-1/2" (140mm) or a maximum of 6" (152mm). See Figure 17-10.

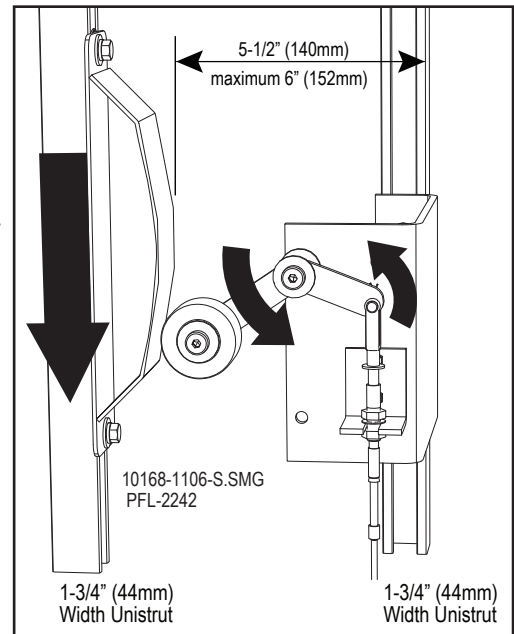

Interlock Position
 Figure 17-10

Straddle Placement

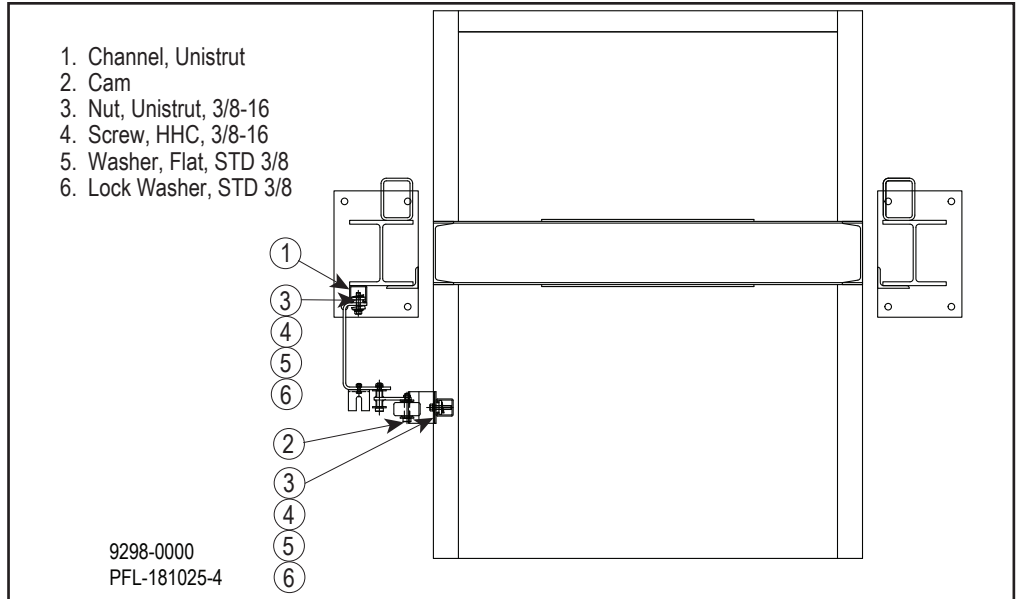

Straddle Placement
 Figure 17-11

Cantilever Placement

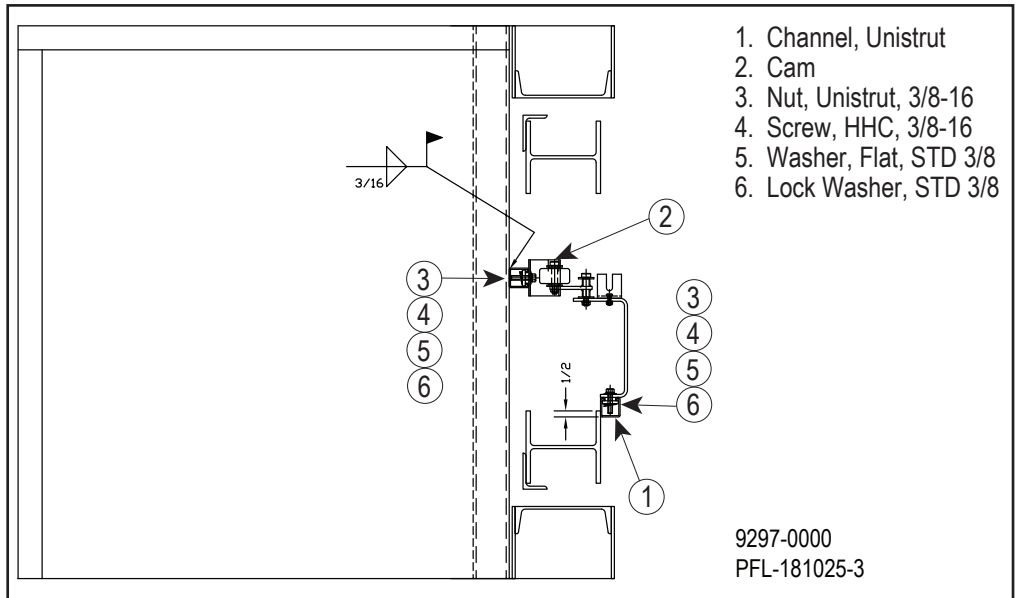

Cantilever Placement
 Figure 17-12

Adjust the Interlock Assembly

The tension on the extension spring should be adjusted by positioning the cable on the angle bracket. The activation of the interlock is also adjusted by the position on the set collar. See Figure 17-13.

Adjust the Cam and Cable

1. Adjust the carriage cam to allow + 3/4" cable travel [2" (51mm) maximum cable travel].
2. Make sure the roller wheel clears the edge of the cam.
3. Center the cable travel by positioning the cable in the bracket angle. See Figure 17-14.
4. The edge of the cam must not be past the center of the wheel toward the bracket. This could catch the wheel at the cam edge and break the cable clevis. See Figure 17-15.

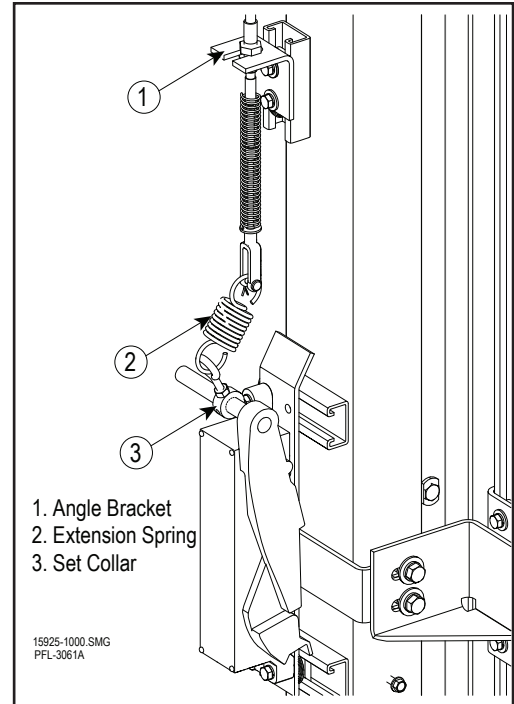

Control Cable Position Figure 17-13

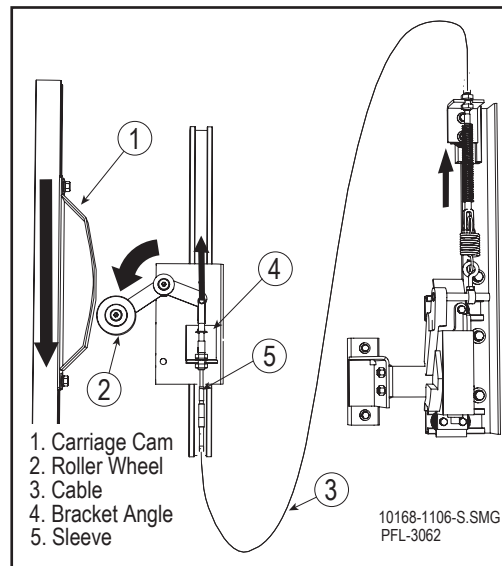

Adjust Roller Wheel (Anderson Shown) Figure 17-14

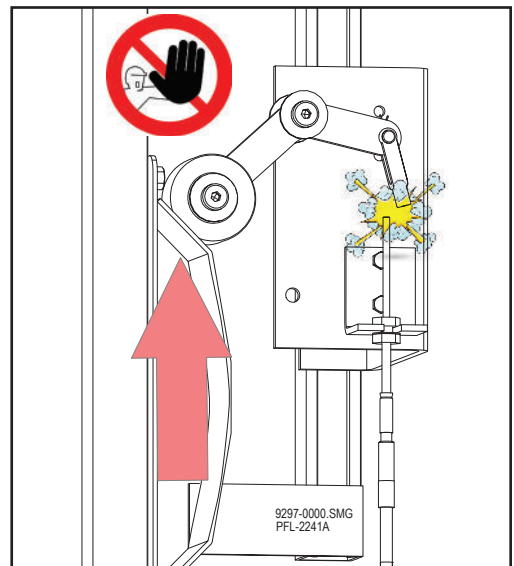

Watch Position of Roller Wheel (Anderson Shown) Figure 17-15



! WARNING

Falling hazard! Proper engagement of the roller and cam is critical. Properly align the safety components to avoid causing the roller arm to push the cable into the sleeve, bend, break, and becoming inoperable.

Position the Roller Arm on the VRC Column

1. The position of the roller on the cam is very important. The roller must roll freely on the cam incline. See Figure 17-16 and Figure 17-17.

NOTICE Do not allow the roller to hang up on the top or bottom horizontal surface of the cam.

2. At the top and bottom levels, the roller arm assembly should be orientated to allow the cam to hit the roller wheel arm in the pivot direction. See Figure 17-16.
3. If the roller assembly position needs to change to an opposite hand, unbolt the angle and pivot arm and reassemble in the new location. See Figure 17-17.

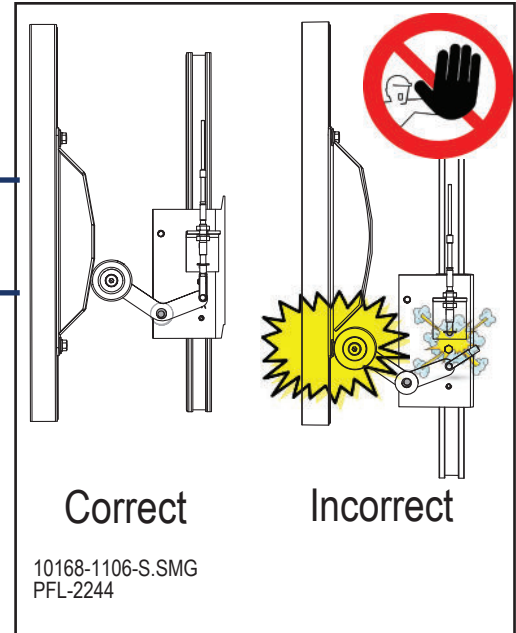

Roller Position
 Figure 17-16

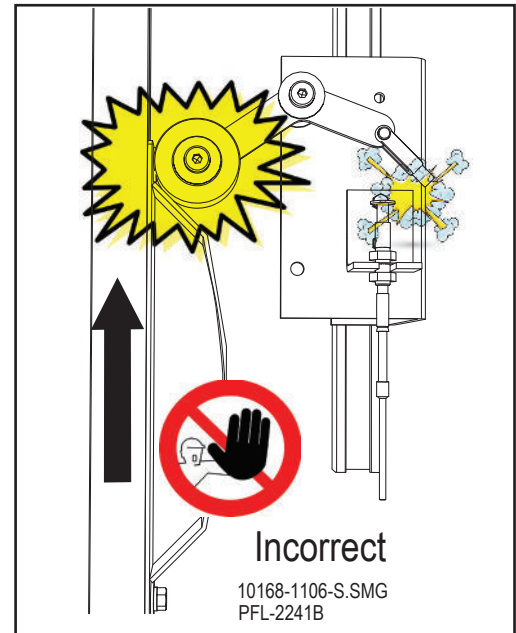

Roller Position
 Figure 17-17

Position the Roller Arm on the VRC Column (continued)

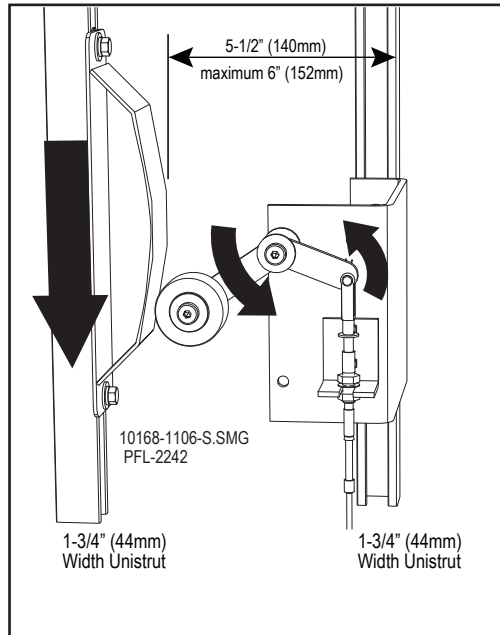

Roller Position
 Figure 17-18

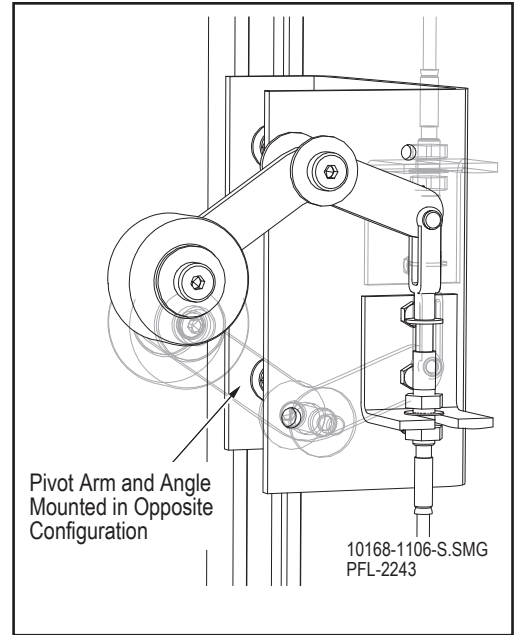

Roller Position
 Figure 17-19

NOTICE Alignment is important. The cam contacts the roller arm in both directions on intermediate levels.

4. The edge of the cam must pass the center of the wheel (away from bracket) to allow pivot arm to rotate. See Figure 17-18.
5. If the cam hits under the wheel and does not allow the arm to pivot, the cable will break. See Figure 17-20.

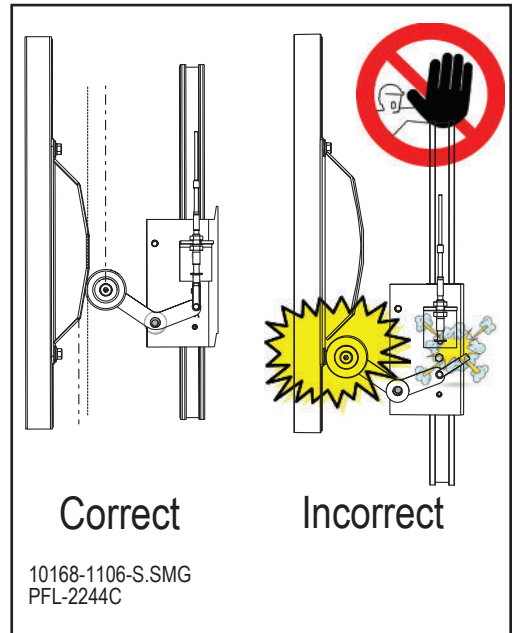

Roller Position
 Figure 17-20

NOTE *There is a right-hand and a left-hand version of the interlock. While facing the gate from the inside of the carriage, the left-hand latch actuator shaft (Figure 17-21, item 2) points left. The right-hand version points right.*

Wire the Single Contact PFlintlock Interlock

1. Loosen and remove the four (4) Phillips screws on the cover plate (item 1) of the replacement interlock. See Figure 17-21.
2. Make sure the latch actuator shaft (item 2) is facing away from the gate.
3. Route the electrical wiring through the bottom access hole (item 4) and alongside the wall of the interlock housing.
4. Loosen the ground screw and connect the ground wire to the ground screw inside the interlock.
5. Pull up and out to remove the spring contact assembly (item 3) from the interlock housing. Use care as to not damage the contact components during removal.
6. Loosen the Phillips screws on the contact sets (item 3) and connect the wires to the contact set per the wiring schematic included.
7. Tighten and torque the Phillips screws on the contact set to 12 lb-in (1,25 N-m).
8. Tighten and torque the ground screw to 20 lb-in (2,25 N-m).
9. Slide the spring contact assembly into the interlock housing using the pins and grooves in the side as a guide. Use care as to not damage the contact components during removal. See Figure 17-22.
10. Make sure the wires are tucked into place to avoid pinching. See Figure 17-23.
11. Replace the cover plate, tighten, and torque the Phillips screws to 10 lb-in (1,13 N-m).

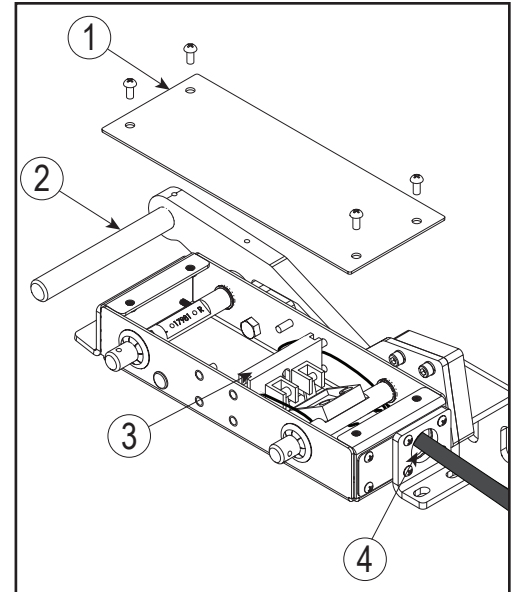

Single Contact PFlintlock Interlock
 Figure 17-21

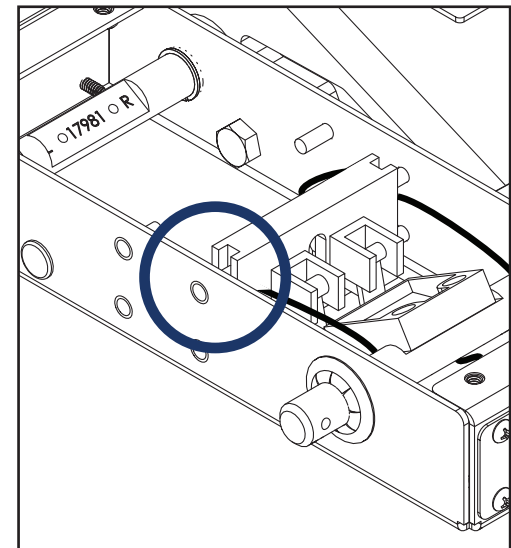

Single Contact PFlintlock Interlock
 Figure 17-22



Single Contact Wiring
 Figure 17-23

NOTE *There is a right-hand and a left-hand version of the interlock. While facing the gate from the inside of the carriage, the left-hand latch actuator shaft (Figure 17-24, item 2) points left. The right-hand version points right.*

Wire the Dual Contact PFlintlock Interlock

1. Loosen and remove the four (4) Phillips screws on the cover plate (item 1) of the replacement interlock. See Figure 17-24.
2. Make sure the latch actuator shaft (item 2) is facing away from the gate.
3. Route the electrical wiring through the bottom access hole (item 4) and alongside the wall of the interlock housing.
4. Loosen the ground screw and connect the ground wire to the ground screw inside the interlock.
5. Pull up and out to remove the spring contact assemblies (item 3) from the interlock housing. Use care as to not damage the contact components during removal.
6. Loosen the Phillips screws on the contact sets (item 3) and connect the wires to the contact set per the wiring schematic included.
7. Tighten and torque the Phillips screws on the contact set to 12 lb-in (1,35 N-m).
8. Tighten and torque the ground screw to 20 lb-in (2,25 N-m).
9. Slide the spring contact assemblies into the interlock housing using the pins and grooves in the side as a guide. Use care as to not damage the contact components during removal. See Figure 17-25.
10. Make sure the wires are tucked into place to avoid pinching. See Figure 17-26.
11. Replace the cover plate, tighten, and torque the Phillips screws to 10 lb-in (1,13 N-m).

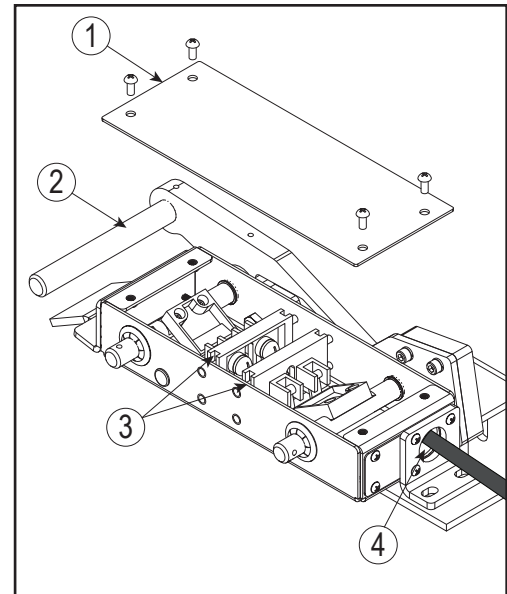

Dual Contact PFlintlock Interlock
Figure 17-24

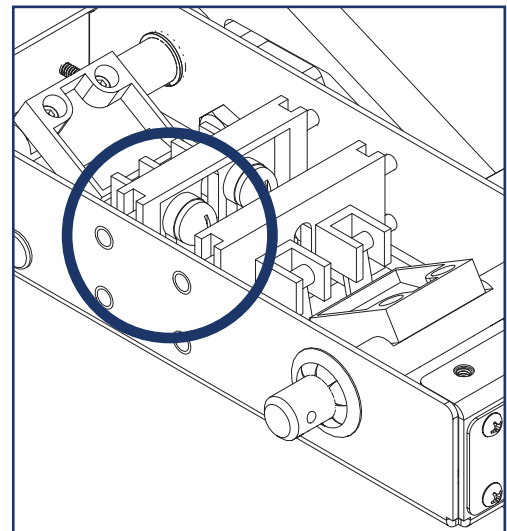

Dual Contact PFlintlock Interlock
Figure 17-25

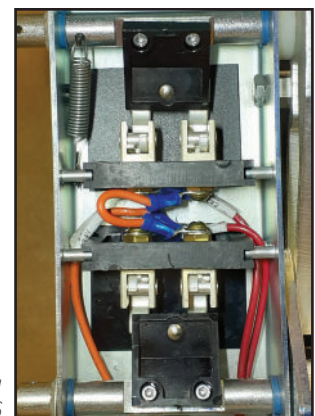

Dual Contact Wiring
Figure 17-26



**Wire the
Electrical Switches**

See the job specific wiring schematic for proper wiring instructions.

A gate status switch is supplied when the contacts are not being used. If required, the switch will be mounted to the gate post or header. Normally, the GAL and Anderson interlocks do not use this switch. Specific order requirements may dictate otherwise.

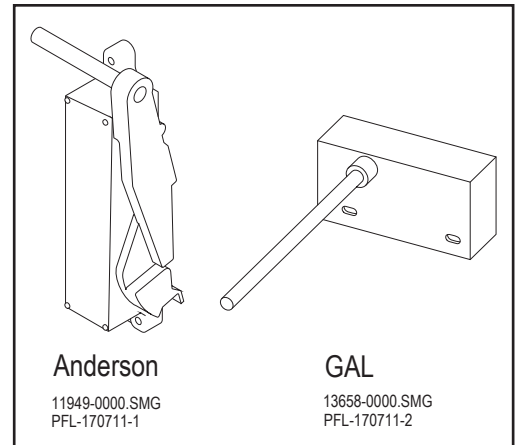

Figure 17-21





Before You Begin

Read this entire manual. Before starting the installation, verify the job site dimensions and the dimensions of the delivered materials against the PFlow Industries, Inc. General Arrangement (GA) drawing. If the site conditions or the delivered materials do not match the GA drawing, please consult the PFlow Industries, Inc. Customer Support Department.



WARNING

Falling panel hazard! The installation of this equipment requires a qualified installer with extensive knowledge and experience on how to rig, erect, and support structural steel. Be sure to properly support, tie off, or temporarily brace the enclosure panels during installation. Do not depend on the enclosure panel feet to support the enclosure panel while the enclosure panel is being positioned or assembled. Final bracing of the enclosure panels must be to the Vertical Reciprocating Conveyor (VRC) or building structure and able to withstand a minimum of 200 pounds of force applied laterally. The use of structural angle is recommended.

CAUTION



Lifting hazard! Components and accessories are heavy. To prevent serious personal injury, use the appropriate lifting apparatus, tie offs, or help when moving, lifting or assembling the components or accessories.

Enclosure Panels

In accordance with ASME B20.1, Section I-3.9, PFlow Industries, Inc. supplies standard 8' (2,438 m) tall enclosure panels to be installed around the Vertical Reciprocating Conveyor (VRC) as required by site conditions. The enclosure panels are steel with 1-1/2" (38mm) angle frame and 16 gauge flattened expanded metal designed to reject a ball 2" (51mm) in diameter.

The PFlow Industries, Inc. GA drawing provides a "Plan View" for each level. Proper placement and appropriate size for layout and installation purposes is shown. See Figure 18-1.

Full Height Enclosures

Applications that require full height enclosures (FHE) will have an additional drawing in the shipping packet.

NOTE When stacking panels, as in full height applications or a transom above a gate, panels without legs are placed above the regular panels.

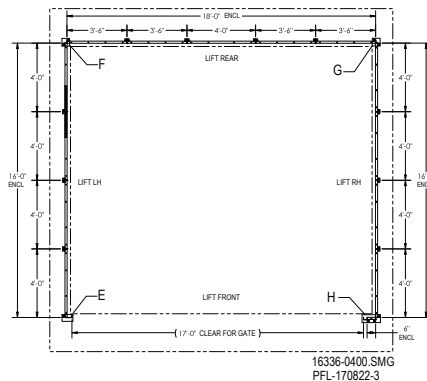

GA "Plan View" Sample Figure 18-1

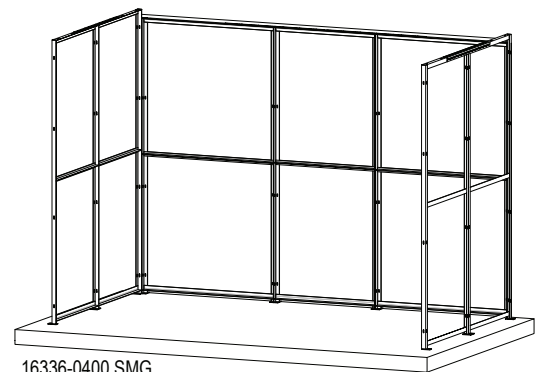

Enclosure Sample Figure 18-2

Identify Components

Enclosure panels have color coded tags. Each tag is a different color.

Level	Tag Color
1st (bottom)	Green
2nd	Yellow
3rd	Red
4th	Blue
Other	Cream

Inventory Enclosure Panels

Before beginning the installation of the enclosure panels, take an inventory of the enclosure panels to make sure the correct number and sizes have been received.

The method of assembly of the enclosure panels will vary due to site conditions. See Figure 18-3 for the general sequence of events.

Assemble and Install Enclosure Panels

1. Bolt together two (2) enclosure panels. See Figure 18-4.
2. Bolt stiffener on top of the two (2) enclosure panels. See Figure 18-5.
3. Bolt corner angle to the enclosure panel for 90° corners. See Figure 18-6.

NOTICE Wall attachment kits are provided when a gate or panel meets an existing wall. See Figure 18-9.

4. Bolt filler panels (if applicable) to the enclosure panel to fill a gap of less than 6" (152mm). See Figure 18-7 on the next page.
5. Bolt attachment tabs to join the full height enclosure panels or stacked enclosure panels.
6. Drill and anchor the enclosure panel feet to the floor with 3/8" anchors, 3-1/2" (89mm) long. See Figure 18-4.

NOTICE The anchor hole depth should always be deeper than the length of the anchor bolt. The recommended wedge anchor size is 3/8" diameter by 3-1/2" (89mm) long.

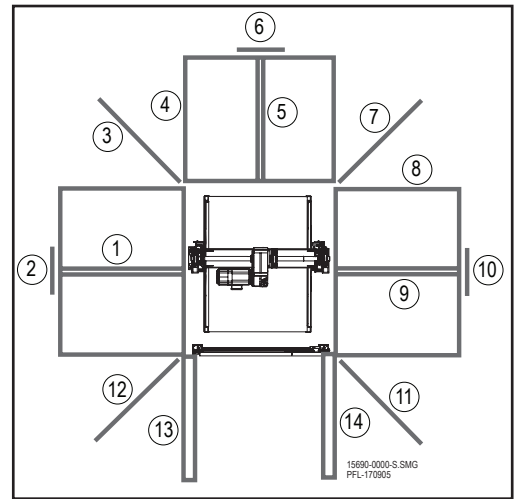

Enclosure Panel Sequence
 Figure 18-3

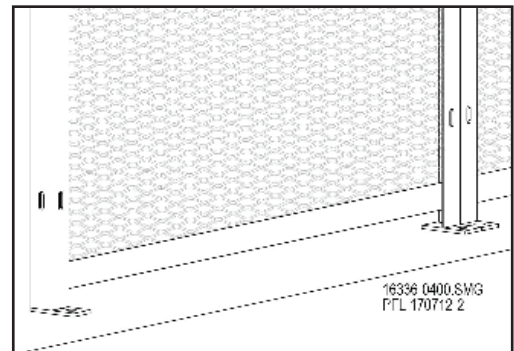

Enclosure Panels
 Figure 18-4

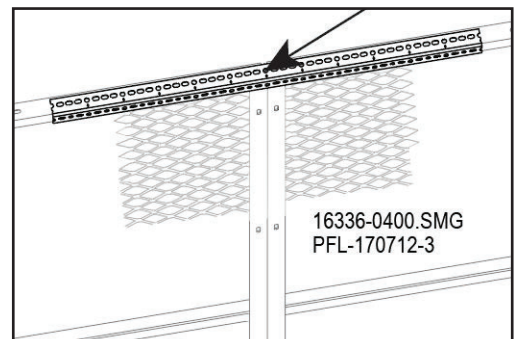

Enclosure Panel Stiffener
 Figure 18-5

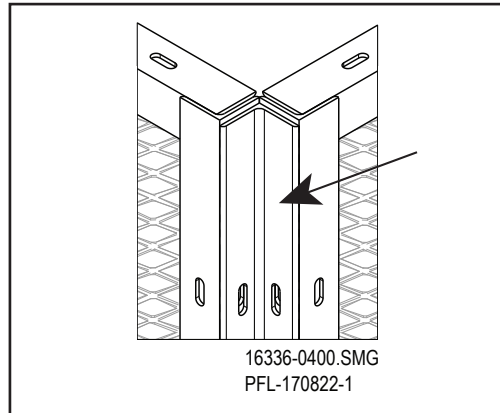

Corner Angle
 Figure 18-6

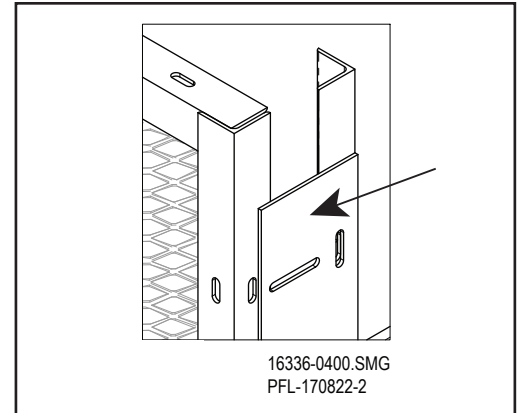

Filler Panel
 Figure 18-7

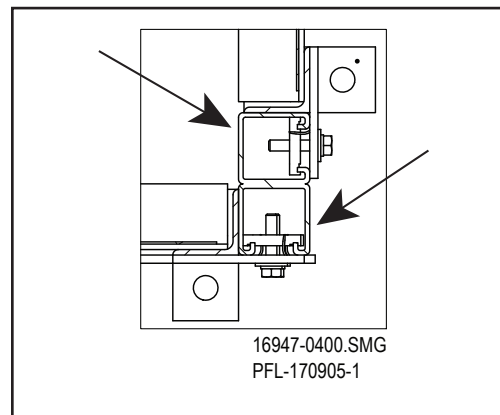

Unistrut Attachment
 Figure 18-8

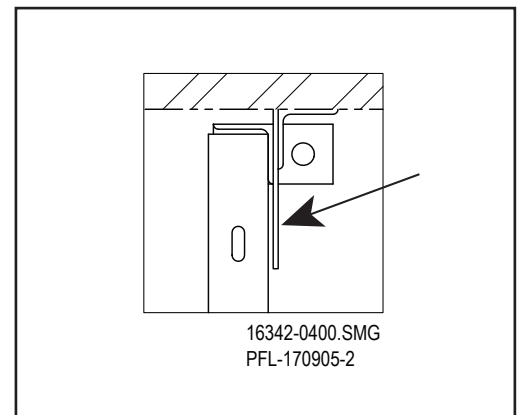

Wall Attachment
 Figure 18-9

NOTICE Enclosures must be braced to the Vertical Reciprocating Conveyor (VRC) or building structure and able to withstand a minimum of 200 lbf applied laterally in accordance with AMSE B20.1-Section I-3.9. The use of structural angle is recommended. Enclosure panels may need to be notched to permit bracing the VRC.





Before You Begin

Read this entire manual.

Purpose

The PFlow Industries, Inc. Vertical Reciprocating Conveyor (VRC) is designed for the movement of materials only, up to the VRC’s rated capacity, from one level to the next. Passengers are not allowed. The placement of capacity labels, and safety warnings are the installer’s responsibility. Make sure the warning labels are placed on each gate and each push-button station.

PFlow Industries, Inc. supplies the appropriate signage in a manila envelope in the parts crate with the original shipment. Contact PFlow Industries, Inc. Customer Support Department for signage if another language is needed.

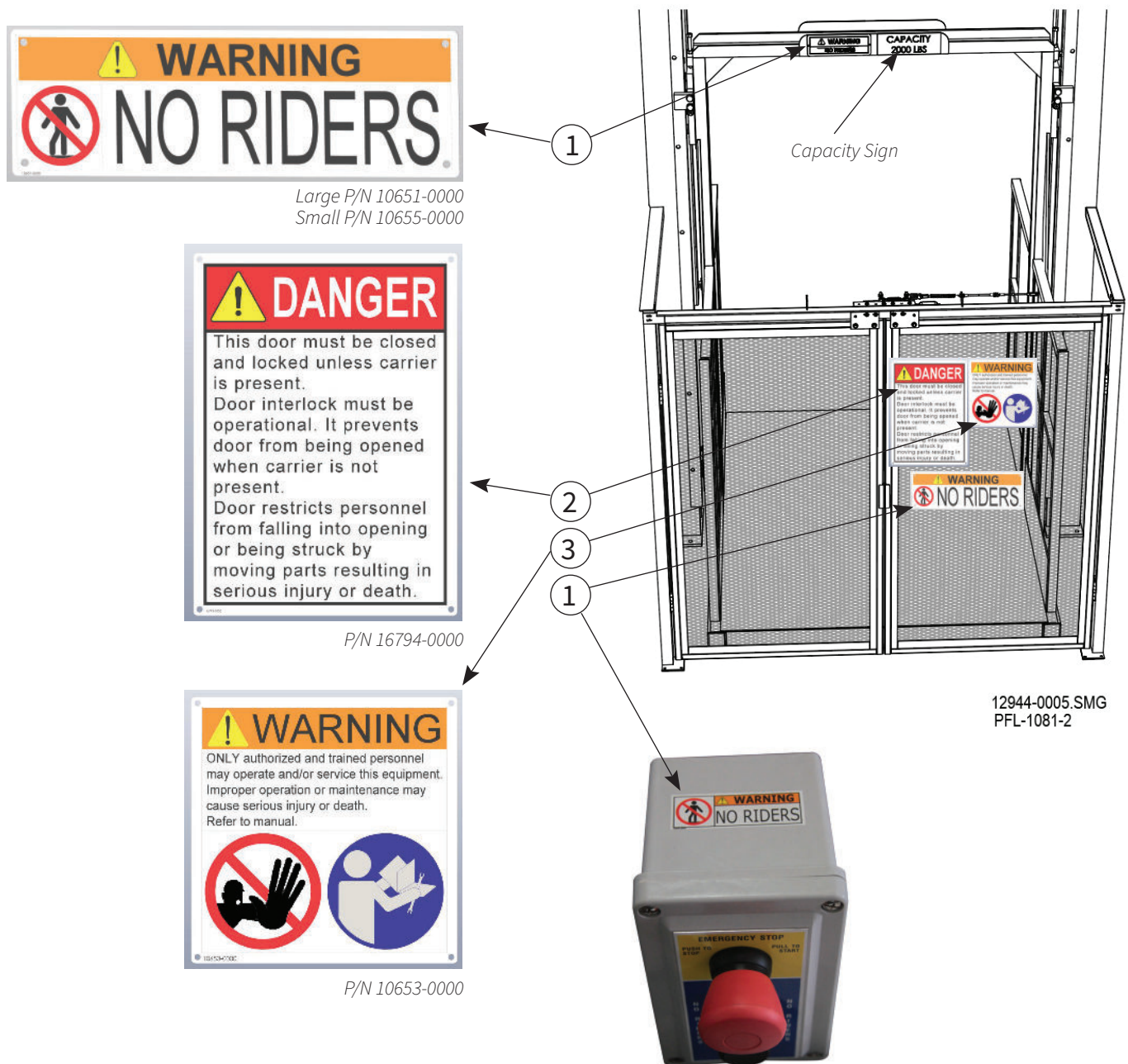

12944-0005.SMG
 PFL-1081-2

Section 19 | Signage Locations



MATERIAL HANDLING SOLUTIONS

www.pflow.com
P 414 352 9000
F 414 352 9002
6720 N. Teutonia Ave.
Milwaukee, WI 53209



Before You Begin

Read this entire manual.

Install the Gate Post Extensions

Gate post extensions may be required to gain additional gate post height and provide clearance between the bottom of the gate panel and the optional landing platform or ramp. If a landing platform or ramp is provided, the gate panel is positioned above the landing platform or ramp.

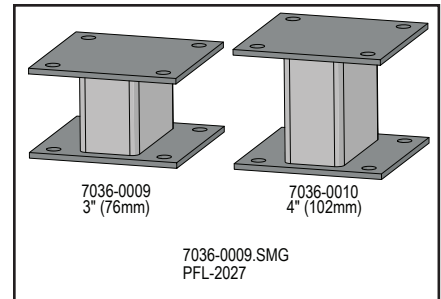

Post Extension Pads
Figure 20-1

The gate post extension allows the gate panel to swing over the top of the landing platform or ramp. See Figure 20-1 and Figure 20-2.

1. Bolt the post extension pad to the bottom of the gate post base plates.
2. Follow the appropriate gate installation instructions.

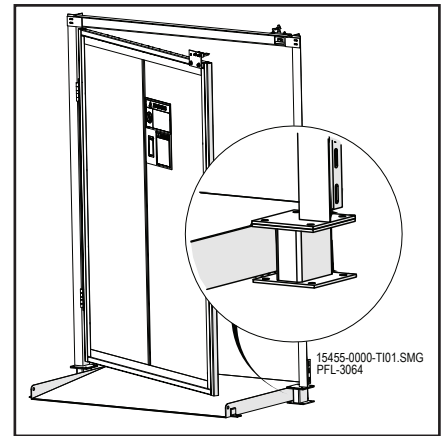

Post Extension Pads and Ramp
Figure 20-2

Install the Landing Platform

1. Position the landing platform 1" (25mm) from the carriage and align with the carriage deck.
2. Make sure the anchoring tabs do not interfere with the gate posts.
3. Weld two (2) anchoring tabs onto both the right side and the left side of the landing platform. See Figure 20-3.
4. Anchor the landing platform to the floor.

NOTICE The anchor hole depth should always be deeper than the length of the anchor bolt. The recommended wedge anchor size is 3/8" diameter by 3-1/2" (89mm) long.

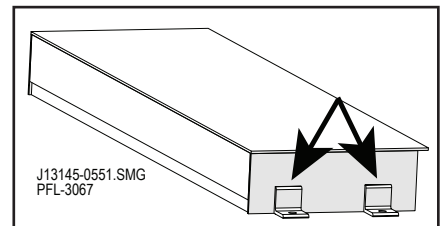

Landing Platform Anchor Tabs
Figure 20-3

Install the Ramp

Ramps are typically provided for first floor levels where the floor is not at the same level as the carriage deck.

Allow additional clearance from the carriage to the ramp. Position the high end of the ramp 1" (25mm) from the edge of the carriage.

1. Weld two (2) anchoring tabs onto both the right side and the left side of the ramp. See Figure 20-4.
2. Anchor the ramp to the floor.

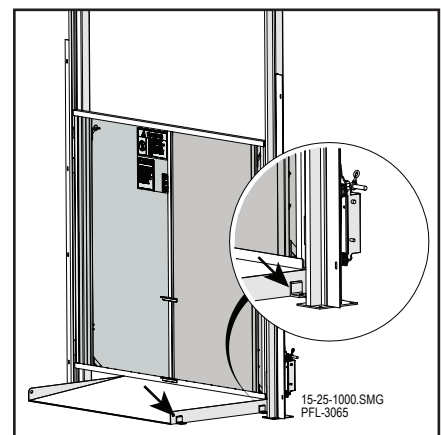

Ramp without Post Extension Pads
Figure 20-4

Section 20 | Landing Platform or Ramp



MATERIAL HANDLING SOLUTIONS

www.pflow.com
P 414 352 9000
F 414 352 9002
6720 N. Teutonia Ave.
Milwaukee, WI 53209



Before You Begin

Read this entire manual.

**Hydraulic Safety
Precautions**



! WARNING



- Wear personal protective equipment, such as Nitrile gloves and safety glasses, whenever installing, servicing, or checking a hydraulic system.
- Hydraulic oil under pressure is extremely dangerous. Assume that all hydraulic hoses and components are pressurized. Relieve all hydraulic pressure before disconnecting any hydraulic fitting, line, or control component.
- Never try to stop or check for a hydraulic leak with any part of your body; use a piece of cardboard to check for hydraulic leaks.
- Small hydraulic hose leaks are extremely dangerous, and can inject hydraulic oil under the skin, even through gloves.
- Infection and gangrene are possible when hydraulic oil penetrates the skin. See a doctor immediately to prevent loss of limb or death.



- Ingesting hydraulic fluid is toxic and hazardous to people and wildlife. Symptoms may be skin irritation, weakness in the hands, intestinal bleeding, pneumonia, or death. Seek first aid immediately. Dispose of spilled fluids appropriately.



- Hydraulic fluid is flammable. Make sure you know where fire extinguishers are kept and how to use them. Do not weld on or near pipes, tubes, or hoses that are filled with fluid.
- Do not overfill the hydraulic oil tank. Any overflow could cause a fire. Immediately repair any hydraulic oil leaks and clean up any spills.
- Shut off all electrical power to the Vertical Reciprocating Conveyor (VRC) while filling the hydraulic oil tank.
- Materials and fluids soaked in hydraulic fluid should be stored in sealed metal containers and disposed of at proper places.



- Hydraulic fluid is slippery. Wipe up spills immediately to reduce the risk of falls or slips.



General Hydraulic Information

- **Weepage** is the normal accumulation of fluid that passes the seals in the course of operation. Make sure the cylinder bleeder valves are closed.
- **Leakage** is the fluid that leaks past worn or cut packing and seals. The carriage will not hold position under load.
- **Working Pressure (WP)** is at the pressure that a hose may be operated safely.
- **Test Pressure** is at the pressure that a hose is guaranteed to withstand.
- **Burst Pressure** is the pressure at which the hose is rendered useless.
- **Date Code** is the date of manufacture.
- Be careful not to nick the extended rod or dent the cylinder casing. This may cause damage to the cylinder seals or packing.
- Paint overspray on the hydraulic cylinder rod will damage the packing seals and void the manufacturer's warranty. Cover exposed rods with removable plastic or cardboard while painting or touching up the VRC.

General Hydraulic Precautions

- Always assume the hydraulic system is under pressure.
- If a carriage becomes stuck above the first floor level, secure the carriage at the stuck position by using chain falls or come-alongs.
- Make sure all pressure is relieved from the hydraulic system before disassembling any components. Fully lower the carriage before opening a line or component.
- Bump the motor in small increments to build hydraulic pressure by pressing the Send to 2 button on the push-button station and then pushing the E-stop button on the push-button station one or two seconds later.
- Avoid contamination of the hydraulic system. Avoid allowing the ends of hoses to fall into oil or dirt. Before connecting any fitting or hose, make sure it is clean and free from debris. If contamination is suspected, flush the system and components.
- Do not install the NPT fittings too tightly. The fittings may crack.



CAUTION

Connect all push-button stations, gate interlocks, and all hydraulic hoses before applying power to the pump motor. Never override any electrical component or manually operate the motor starter to operate the Vertical Reciprocating Conveyor (VRC).

NOTE

Keep the area around the hydraulic pump and motor clean and free from obstructions. Avoid hot spots. Any restriction to the required ventilation will increase the ambient temperature of the hydraulic pumps' location. The increased temperature affects the overall operation and shortens the life of the hydraulic system.

Install the Hydraulic Pump

Contact the PFlow Industries, Inc. Customer Support Department immediately concerning any questions.

Review the GA Drawing for Placement

Install the hydraulic pump and motor on a level, static, and solid foundation at the recommended floor level listed on the PFlow Industries, Inc. General Arrangement (GA) drawing.

Placement Considerations

Install the hydraulic pump and motor in a location that is easily accessible. The ability to service and inspect the hydraulic pump and motor is an important consideration in the life of the hydraulic system. The oil breather cap, manifold block, pressure gauge, pressure switch, and oil filter must be visible and accessible.

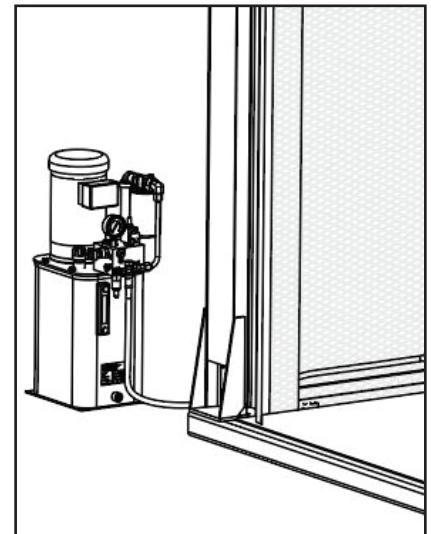

Hydraulic Pump and Motor Location
Figure 21-1

Clean the Fittings and Hoses

NOTE Leave the shipping protection (caps and plugs) installed in the hose fitting ends until the hoses are ready to be connected. A small, almost undetectable, amount of joint compound, dirt, lint, paint, or any other contaminant can prevent the hydraulic system from operating properly.

Clean all mating fittings and hose ends carefully and thoroughly before attaching to the hose or cylinder.

Attach the Fittings and Hose to the Cylinder

NOTE O-ring face seal fittings are sensitive to over and under-torque. Torque to proper specifications (e.g., 3/8" hose fittings 30 lb-ft [41 N-m]; 1/2" hose fitting 40 lb-ft [54 N-m].)

The torque method of assembly is strongly recommended. If open sided torque wrenches are not available, use the Flats From Wrench Resistance (F.F.W.R.) method. Wrench tighten the nut onto the fitting body until wrench resistance is reached. Tighten one-half to three-quarter turns to seat the O-ring.

1. Remove the supply port plug on the cylinder. See Figure 15-2.
2. Remove the plastic caps from the velocity fuse.
3. Make sure the O-rings on the velocity fuse are seated properly and without any kinks. See Figure 21-3.
4. Insert the velocity fuse into the supply port of the cylinder with the inscribed arrow pointing away from the cylinder. See Figure 21-3.
5. Tighten the velocity fuse, then torque to 40 lb-ft (54 N-m).
6. Remove the plastic cap from one end of the hose assembly.
7. Attach the hose to the velocity fuse.
8. Tighten the hose, then torque to 30 lb-ft (41 N-m).
9. Carefully route the hose from the VRC to the hydraulic pump making sure to:
 - Provide adequate slack without pulling taut.
 - Avoid tangling with other VRC components.
 - Eliminate any twists, kinks, and sharp bends.

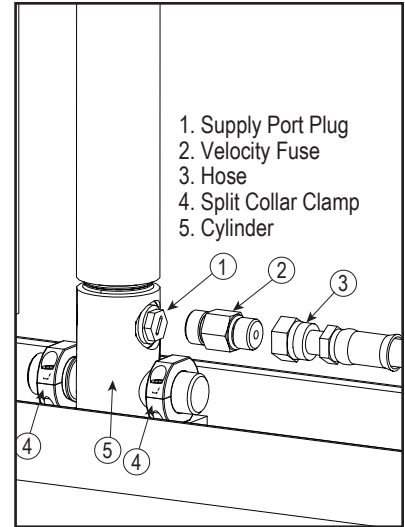

Connect Hydraulic Hose to Cylinder
Figure 21-2

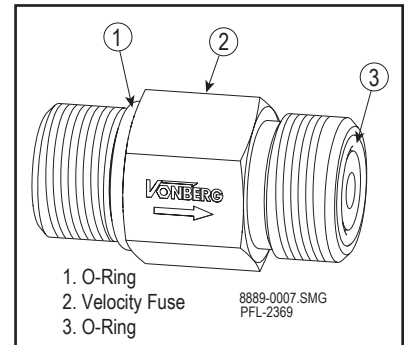

Directional Arrow on Velocity Fuse
Figure 21-3

Attach the Fittings and Hose to the Hydraulic Pump

NOTE Leave the shipping protection (caps and plugs) installed in the hose fitting ends until the hoses are ready to be connected. A small, almost undetectable, amount of joint compound, dirt, lint, paint, or any other contaminant can prevent the hydraulic system from operating properly.

1. Remove the plastic insert from the valve block. See Figure 21-4.
2. Make sure the O-ring on the adapter is seated properly and without any kinks.
3. Place the plastic insert into the hydraulic valve block.
4. Tighten the insert, then torque to 40 lb-ft (54 N-m).
5. Remove the plastic caps from the elbow.
6. Install the elbow onto the adapter.
7. Tighten the elbow, then torque to 30 lb-ft (41 N-m).
8. Coil and strap any excess hose.
9. Remove the plastic cap from the end of the hose assembly.
10. Attach the hose to the elbow.
11. Tighten the hose, then torque to 30 lb-ft (41 N-m).

NOTE If an additional hose(s) was received, an adapter is supplied by PFlow Industries, Inc. to couple the hoses together.

Thread Sizes

Adapter – 3/4-16 Straight Thread O-ring (into the hydraulic pump), 13/16-16 O-ring Face Seal (to the elbow)

Elbow – 13/16-16 O-ring Face Seal (female) into the Adapter, 13/16-16 O-ring Face Seal (male) to the hose

Hose – 13/16-16 O-ring Face Seal (female) at both ends, 3/8" Inside diameter

Velocity Fuse – 3/4-16 Straight Thread O-ring (into the cylinder), 13/16-16 O-ring Face Seal (male) to the hose

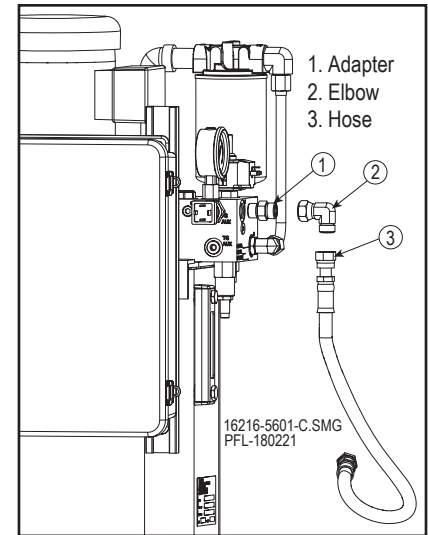

Connect Hydraulic Hose to Hydraulic Pump
Figure 21-4

Install the Breather Cap



Most components on the hydraulic pump motor unit are preset at the factory. Adjustments to those factory settings should not be necessary. See Figure 21-5 for easy identification. Before making any adjustments, contact the PFlow Industries, Inc. Customer Support Department for help.

1. Unscrew and remove the small plastic insert in the fill port.
2. Replace the insert in the fill port with the plastic breather cap. See Figure 21-5.

CAUTION

Connect all push-button stations, gate interlocks, and all hydraulic hoses before applying power to the pump motor. Never override any electrical component or manually operate the motor starter to operate the Vertical Reciprocating Conveyor (VRC).

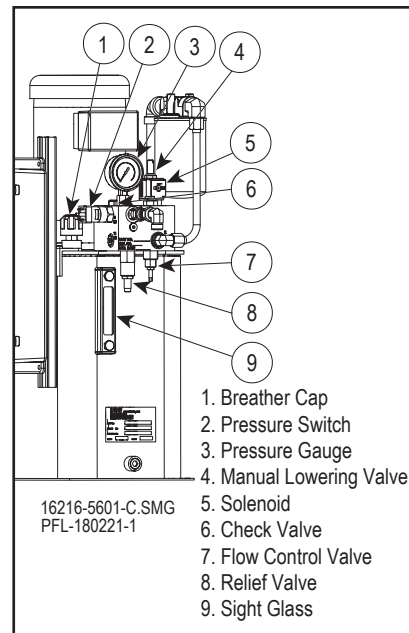

Hydraulic Pump Motor Components
Figure 21-5

Start-Up Procedures

1. Confirm that all bolts are tight.
2. Confirm that all finish welds are complete.
3. Confirm that the oil level in the sight glass on the side of the hydraulic tank is between the black line and the red line.

Confirm E-stop Safety Operation

1. While you and the carriage are at the first level, push in the E-stop button on the push-button station.
2. Push the Send to 2 button on the push-button station. The carriage should not move.
3. Pull out the E-stop button on the push-button station.
4. Push the Send to 2 button on the push-button station. The carriage should begin to travel to the second level.
5. Push in the E-stop button on the push-button station. The carriage should stop moving.

Confirm Motor Rotation

1. Remove the fan cover from the motor. See Figure 21-6.
2. Push the Send to 2 button on the push-button station just long enough to confirm that the motor is rotating in the correct direction. Rotation should match the directional arrow on the motor housing. Push in the E-stop button on the push-button station.

NOTE *If the motor is not operating in the correct direction, stop the motor immediately. Have a qualified electrician inspect and switch any of the two out of three wires of the incoming 3-phase power for the motor. Confirm that the motor rotation is correct after any wiring change has been made.*

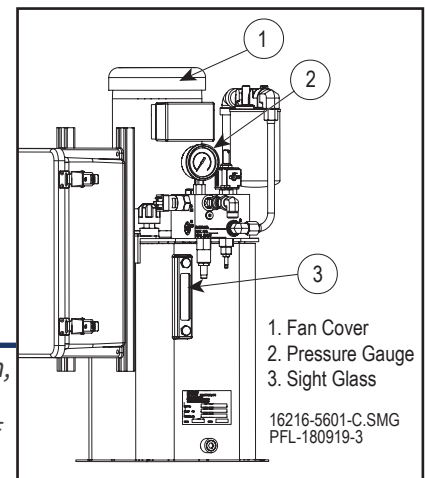

Confirm Motor Rotation
Figure 21-6

If nothing happens when the Send to 2 button is pushed, contact PFlow Industries, Inc. Customer Support Department for troubleshooting assistance.

3. Replace the fan cover.
4. Pull out the E-stop button on the push-button station.

Make Sure There are No Leaks

1. Push the Send to 2 button on the push-button station.
2. Allow the carriage to raise off the ground three to five inches.
3. Push in the E-stop button on the push-button station.
4. Pull out the E-stop button on the push-button station.
5. Push the Send to 1 button on the push-button station.
6. Confirm that there are no leaks at any of the joints along the hydraulic system.

**Confirm that
the Pump Motor
Shuts Off**

NOTICE

Push the Send to 2 button on the push-button station. Make sure that the pump motor shuts off when the carriage deck reaches the second floor level.

If the pump motor does not stop, do not leave the VRC unattended. Components may overheat.

**Adjust Pressure
Relief Valve
(if needed)**

If the pump motor does not stop:

1. Verify the PSI switch settings and the relief valve settings. Refer to the decal on the side of the tank.
2. Jump (terminals 3031-3032) out the PSI switch.
3. Push the Send to 2 button on the push-button station. The VRC will not shut off.
4. Push the E-stop button on the push-button station to stop the carriage. While the carriage is moving up, note the PSI value on the pressure gauge when the lift hits full height and the pressure goes beyond the pressure relief valve setting. See Figure 21-7.
5. Reset the PSI relief valve setting as indicated on the decal on the side of the tank. Adjust the pressure relief clockwise (CW) to raise the pressure or counterclockwise (CCW) to lower pressure. Typically, adjust the pressure relief valve ¼ turn at a time.
6. Test the results by lowering the VRC carriage a few feet, pressing the E-stop button, then pushing the Send to 2 button on the push-button station to send the carriage up to the second floor.
7. Return the carriage to the first floor.
8. Remove the jumper wire.
9. Push the Send to 2 button on the push-button station. The pump should shut off between 300-400 PSI below the PSI relief setting. If not, adjust the pressure switch.

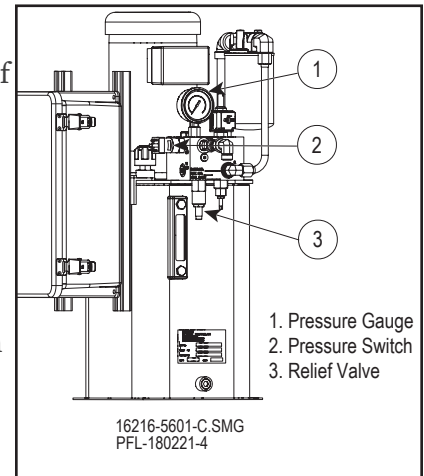

Adjust Pressure Relief Valve
Figure 21-7

NOTE If the motor pump does not shut off between 300-400 PSI below the PSI relief setting, adjust the pressure switch.

**Adjust Pressure
Switch (if needed)**

1. Remove the plug cover on the pressure switch. See Figure 21-8.
2. Remove the brass insert.
3. Use a 1/8" hex key to turn the adjustment setscrew clockwise (CW) to increase the pressure setting or counterclockwise (CCW) to decrease the pressure setting. Typically, adjust the pressure switch 1/4 turn at a time.
4. Retest lift and re-adjust the pressure switch until the setting is correct.

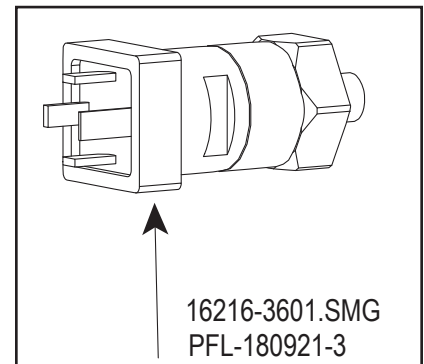

Adjust Pressure Switch
Figure 21-8



**Confirm Carriage
Stops are Level
with the Floor**

1. Push the Send to 2 button on the push-button station. Push the E-stop button just before the carriage reaches the second floor level.
2. Adjust the carriage stop jack screws on the backframe to allow the carriage deck to stop level with the second floor.
3. Push the Send to 1 button on the push-button station. Make sure the underside of the carriage is shimmed properly and that the carriage deck stops level with the first floor.

**Confirm Carriage
Travel Speeds**

Push the Send to 2 button on the push-button station and time the carriage going up. Push the Send to 1 button on the push-button station and time the carriage coming down. The speed of the carriage traveling up and traveling down should match.

NOTE *If the speeds do not match, adjust the flow control valve. Call PFlow Industries, Inc. Customer Support Department for troubleshooting assistance.*

**Confirm Gate
Safety Operation**

1. While you are at the first level and the carriage is traveling up, attempt to open the first level gate door. The gate door **should not** open while the carriage is traveling, and the carriage should continue to travel up.

NOTE *If the carriage stops but the gate door will not open, call PFlow Industries, Inc. Customer Support Department for troubleshooting assistance.*

2. While the carriage is at the second level, attempt to open the first floor level gate door. The gate door **should not** open.
3. Push the Send to 1 button on the push-button station.
4. Attempt to open the first floor level gate door. The gate door **should not** open.
5. Attempt to open the first floor level gate door when the carriage has reached the first floor level. The gate door **should** open.

NOTE *If the gate door does **not** open, refer to the interlock section of the installation manual for needed adjustments.*

6. Close the gate door. Push in the E-stop button on the push-button station. Push the Send to 1 button on the push-button station. The carriage should not move.
7. Pull out the E-stop button on the push-button station. Push the Send to 2 button on the push-button station. The carriage should begin to travel up.

Repeat the E-stop Safety Operation steps and the Gate Safety Operation steps at each level.



**Conduct a
Load Test**

WARNING

Avoid Shifting Loads! Place the load in the center of the lift platform. Make sure that any portion of the load does not overhang the perimeter of the carriage. This could create an unstable load condition.

With the carriage deck at the first level, add weight up to, but not to exceed, the VRCs rated capacity:

1. Position the load in the center of the carriage deck against the back frame.
2. Lock the wheels on all wheeled carts.
3. Close the gate and push the Send to 2 button on the push-button station.
4. Monitor the position of the carriage deck as it reaches the second level.
5. Continue to monitor the position of the carriage deck. Allow the VRC to hold the carriage at the upper level for 15 minutes.

NOTE

The hydraulic cylinder is not holding pressure if the carriage deck drops below the second level. Make a note of the weight used, and the amount of time that the carriage deck held the position before dropping down. Push the Send to 1 button and contact PFlow Industries, Inc. Customer Support Department for troubleshooting assistance.

Before You Begin

Read this entire manual.

The Purpose of the Motor Overload Sensor (MOL)

The PFlow Industries, Inc. D series Vertical Reciprocating Conveyor (VRC) is equipped with a Motor Overload Sensor (MOL). The MOL is prewired and located inside the electrical control panel. See Figure 22-1.

The MOL monitors the motor amp draw and provides enhanced over current protection of the lift motor. The MOL must be adjusted to the maximum “expected” current draw. If the motor current rises above the MOL set point, the MOL will trip. Tripping can be caused by a circuit malfunction, overloading the capacity of the lift, or an overhanging load trapped between floors.

Locate the Full Load Amperage (F.L.A.) Value

1. Review the electrical drawing J#-0050.
2. Locate the hydraulic pump motor information on page 1 or page 2. The F.L.A. value is listed after the HP value. See Figure 22-2. The information may also be found on the VRC Specification for this job.

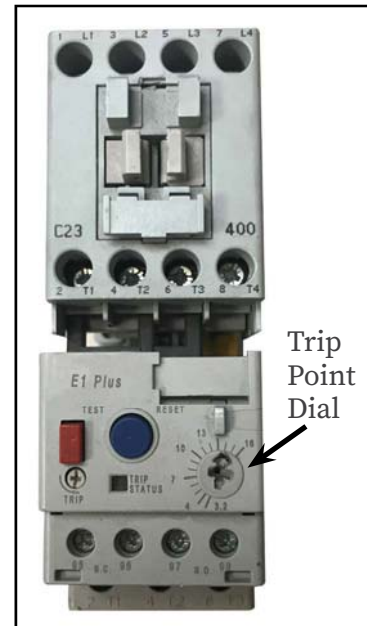

Motor Overload Sensor Figure 22-1

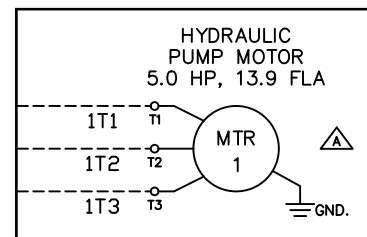

Sample Pump Motor Information Figure 22-2

Test and Calibrate the MOL

1. Turn the trip point dial to match the F.L.A. value.
2. Place the maximum product load on the carriage.

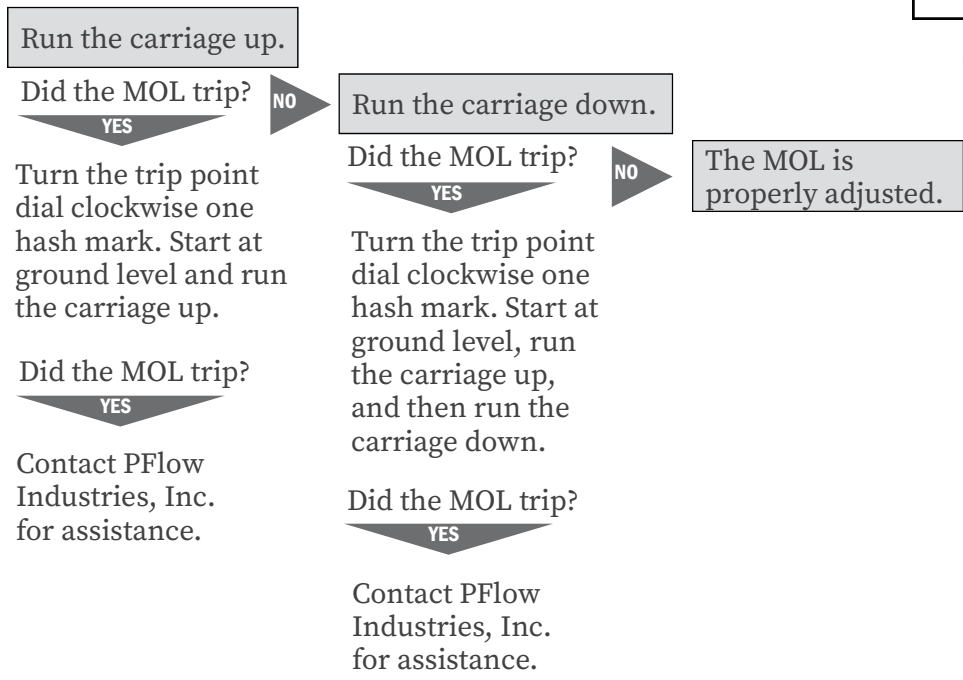

Section 22 | Adjust Motor Overload Sensor



MATERIAL HANDLING SOLUTIONS

www.pflow.com
P 414 352 9000
F 414 352 9002
6720 N. Teutonia Ave.
Milwaukee, WI 53209



**Section 23 | D Series Installation
Completion Checklist**



MATERIAL HANDLING SOLUTIONS

www.pflow.com
P 414 352 9000
F 414 352 9002
6720 N. Teutonia Ave.
Milwaukee, WI 53209

**Post Installation
Checklist**

Make sure all steps are completed. Sign and return to PFlow Industries, Inc. Customer Support Department via e-mail to csd@pflow.com

✓	Verify Mechanical Completion
	All bolts are tight.
	Final bracing for the VRC is completed from front to back and from side to side. Inspect each level.
	Final bracing for the gates and enclosures are completed. Inspect each level.
	The gate door opens when the carriage is present. Inspect each level.
	The gate door does not open when the carriage is not present. Inspect each level.
	Excess gate interlock cables are routed as straight as possible and not spooled in coils tighter than 28" (711mm).
	All operational signs are posted.
	All weld marks, scrapes, etc. are touched up with paint.
	The breather cap has been installed on the hydraulic pump.
	The hydraulic oil level in the sight glass is between the black line and the red line.
	The motor is rotating in the correct direction.
	There are no hydraulic oil leaks.
	The carriage stops level with each floor.
	The hydraulic pump motor shuts off when the carriage deck reaches the second floor.
	There is no excessive noise or binding during travel.
	Additional options and accessories (e.g., DeckLocks, maintenance pins) are tested and working properly.
	The installation site is clean and all debris is removed.
	The customer received instructions regarding proper lift operation.
	The customer received instructions regarding preventive maintenance of the VRC.
	The customer received instructions regarding procedures in the event of a problem or safety related issues.
	Identify any unsafe condition. Document and report the condition immediately to the customer and then PFlow Industries, Inc. Customer Support Department. Do not allow the lift to operate when unsafe conditions arise.



Additional Notes or Follow-up Requirements

PFlow Serial Number:	Customer/User:	Date:
Mechanical Checklist Completed by:		E-mail Address:
Company:		Phone Number:

Section 23 | D Series Installation Completion Checklist



MATERIAL HANDLING SOLUTIONS

www.pflow.com
P 414 352 9000
F 414 352 9002
6720 N. Teutonia Ave.
Milwaukee, WI 53209

Post Installation Checklist

Make sure all steps are completed. Sign and return to PFlow Industries, Inc. Customer Support Department via e-mail to csd@pflow.com

✓	Verify Electrical Completion
	Make sure all electrical connections are tight and properly made.
	The push button stations operate correctly on all floor levels.
	The emergency stop buttons operate correctly on all floor levels.
	The MOL has been adjusted and the full load test is completed.
	The gate door opens when the carriage is present. Inspect each level.
	The gate door does not open when the carriage is not present. Inspect each level.
	The VRC does not operate with any gate open.
	Additional options and accessories (e.g., DeckLocks, maintenance pins) are tested and working properly.
	The installation site is clean and all debris is removed.
	The customer received instructions regarding electrical control panel location and power shutoffs.
	The customer received instructions regarding procedures in the event of a problem or safety related issues.
	Identify any unsafe condition. Document and report the condition immediately to the customer and then PFlow Industries, Inc. Customer Support Department. Do not allow the lift to operate when unsafe conditions arise.



Additional Notes or Follow-up Requirements

PFlow Serial Number:	Customer/User:	Date:
Electrical Checklist Completed by:	E-mail Address:	
Company:	Phone Number:	

Section 24 | Installation Questionnaire



MATERIAL HANDLING SOLUTIONS

www.pflow.com
P 414 352 9000
F 414 352 9002
6720 N. Teutonia Ave.
Milwaukee, WI 53209

Thank You

PFlow Industries, Inc. would like to thank you for the opportunity to serve you. Your business is appreciated. Please help us to ensure that your expectations are met by taking a few minutes to tell us about the equipment and service that you have received. Complete the Installation Questionnaire and Acceptance Certificate. Return both forms to PFlow Industries, Inc. via e-mail to csd@pflow.com Additional space for comments is available on the next page.

Yes ✓ No ✓

Product Perception

Was the equipment shipment complete as expected?		
--	--	--

What items were missing, if any?

Was the equipment in good condition?		
--------------------------------------	--	--

Describe the equipment damage or concerns with the workmanship, if any.

Did the equipment match the General Arrangement (GA) drawing?		
---	--	--

Was the equipment dimensionally correct with form, fit, and function?		
---	--	--

Describe any problem areas in detail.

Electrical Installation

Was the electrical field wiring completed as required?		
--	--	--

Were there any issues with the electrical components?		
---	--	--

After the electrical installation was completed, was it necessary to return for final adjustments, testing, and training?		
---	--	--

Were you made aware of any electrical problems?		
---	--	--

Describe any "No" answers in detail.

Testing

Was the equipment tested at full load capacity?		
---	--	--

Were all gates tested to ensure proper operation and interlock operation?		
---	--	--

PFlow Serial Number	Customer/User	Date
Questionnaire Completed by		E-mail Address
Company		Phone Number

Section 24 | Installation Questionnaire



MATERIAL HANDLING SOLUTIONS

www.pflow.com
P 414 352 9000
F 414 352 9002
6720 N. Teutonia Ave.
Milwaukee, WI 53209



**Section 25 | Acceptance
Certification - VRC**



MATERIAL HANDLING SOLUTIONS

www.pflow.com
P 414 352 9000
F 414 352 9002
6720 N. Teutonia Ave.
Milwaukee, WI 53209

Acceptance

We, the Customer, accept the equipment listed below as being properly installed, tested, and performing to our satisfaction. This form covers both the mechanical and the electrical installation of the equipment. This acceptance in no way releases either PFlow Industries, Inc. or the installing contractor(s) of any warranty obligations. If there are any exceptions or unresolved items, please include detailed information.

PFlow Serial Number:	Model Number:	<input type="checkbox"/> B	<input type="checkbox"/> D	<input type="checkbox"/> DB	<input type="checkbox"/> F	<input type="checkbox"/> M	<input type="checkbox"/> MQ	<input type="checkbox"/> 21	<input type="checkbox"/> CV	Other _____
Job Name:										
Site Street Address:										
Site Mailing Address:										
Site City:							State:		Zip Code:	
Customer Contact Name:							Contact Title:			
Customer Contact Phone: ()							Ext		E-Mail:	

Tests Performed	Load Capacity:				Start-up Date:
	Load Test:	<input type="checkbox"/> Yes	<input type="checkbox"/> No	at ____ % of lift capacity	Customer Initials:
	Operation Test:	<input type="checkbox"/> Yes	<input type="checkbox"/> No		Comments:
	Gate/Interlock Operation:	<input type="checkbox"/> Yes	<input type="checkbox"/> No	<input type="checkbox"/> Not Applicable	
	Other Test:				
	Other Test:				

Personnel Instructed on the Operation and Preventive Maintenance:	
Name:	Company:
Name:	Company:

Accepted by:	Acceptance Date:
Name/Phone:	PFlow Rep Present:
Title:	Name:
Company:	Company:

Please return a copy of this form to the PFlow Industries, Inc. Customer Support Department at csd@pflow.com.

**Section 25 | Acceptance
Certification - VRC**



MATERIAL HANDLING SOLUTIONS

www.pflow.com
P 414 352 9000
F 414 352 9002
6720 N. Teutonia Ave.
Milwaukee, WI 53209

