

Before You Begin

Read this entire manual.

Before starting the installation, verify the job site dimensions and the dimensions of the delivered materials against the PFlow Industries, Inc. General Arrangement (GA) drawing. Review and verify the enclosure positions and attachment fit-up to the gate post enclosure angle. If the site conditions do not match the GA drawing, please consult the PFlow Industries, Inc. Customer Support Department.



! DANGER

Falling gate hazard! The installation of this equipment requires a qualified installer with extensive knowledge and experience on how to rig and erect structural steel. Make sure to properly support, tie off, or temporarily brace the gate posts, gate panels, and gate assembly during installation. Do not depend on the gate post feet to support the gate posts while the gate is being positioned or assembled. Final bracing of the gate assembly must be to the Vertical Reciprocating Conveyor (VRC) or building structure. The use of structural angle is recommended.



Falling Hazard! The gate panel safety latch may not be operational while the gate is being installed. If you must leave a gate or gate panel unattended, put up barriers and signs warning personnel to stay clear.

! CAUTION



Lifting hazard! Components and accessories are heavy. To prevent serious personal injury, use the appropriate lifting apparatus, tie offs, or help when moving, lifting or assembling the components or accessories.

NOTICE

A qualified person is defined as a person who, by possession of a recognized degree or certificate of professional standing, or by extensive knowledge, training, and experience, has successfully demonstrated his/her ability to solve problems relating to the subject matter and work.

Identify Components

Gate components, posts, panels, and header assembly have color coded tags. Each gate tag is a different color.

Level	Tag Color
1st (bottom)	Green
2nd	Yellow
3rd	Red
4th	Blue
Other	Cream

The preferred method of installing a gate is to pre-assemble the full gate assembly on the floor, secure the pieces, and then stand it up. If for some reason pre-assembly is not possible, use these instructions as a general guide for the assembling, positioning, and securing of the gates.

Gate Installation

Single Vertical Acting (SVA) Gate



MATERIAL HANDLING SOLUTIONS

www.pflow.com
 P 414 352 9000
 F 414 352 9002
 6720 N. Teutonia Ave.
 Milwaukee, WI 53209

Establish Placement

NOTE *It is often possible to assemble the gate on the ground. However, it may not be possible to erect the fully assembled gate.*

Horizontal assembly and vertical assembly methods are included in this manual. Both methods require additional support and temporary bracing during assembly.

1. Measure the outside edge to the outside edge of the carriage to locate the center line. Mark the center line with a pencil on the top of the carriage deck. See Figure 1.
2. Position a carpenter square on the edge of the carriage to extend the center line onto the floor a distance of 10" (254mm) away from the carriage.
3. Mark a chalk line on the floor to ensure the center of the gate is on the center line of the carriage.

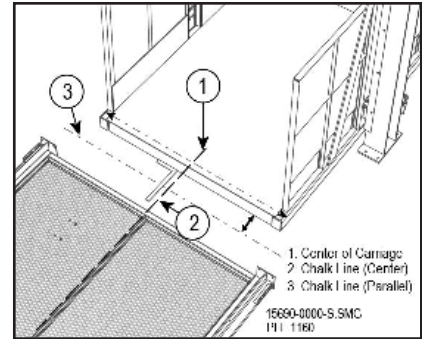

Establish Center Line
 Figure 1

NOTE *The ideal position of the gate panel is a maximum of 6" (152mm) from the inside of the gate panel to the front edge of the carriage. Local codes may have specific requirements concerning this distance.*

4. When the measurement from the back side of the gate panel to the carriage has been determined, snap a chalk line to identify the position of the gate panel parallel to the carriage. See Figure 1.
5. Reference the PFlow Industries, Inc. General Arrangement (GA) drawing to determine the overall gate width.
6. Measure the overall gate width and mark the final position for the gate posts. See Figure 2.

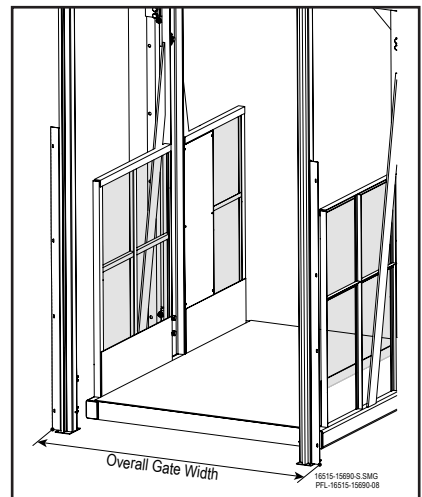

Establish Gate Width
 Figure 2

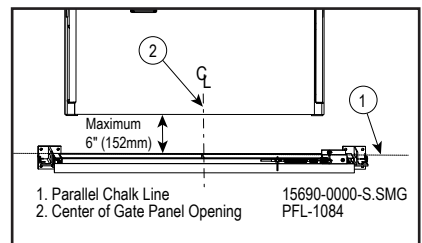

Alignment
 Figure 3

Gate Installation

Single Vertical Acting (SVA) Gate



MATERIAL HANDLING SOLUTIONS

www.pflow.com
P 414 352 9000
F 414 352 9002
6720 N. Teutonia Ave.
Milwaukee, WI 53209

Prepare the Chains in the Gate Posts

For shipping purposes, the single vertical acting gate panel counterweight is secured with a shipping screw located toward the bottom of the gate post assembly.

To prevent the chain from falling down into the gate post:

1. Remove shipping screw located toward the bottom of the gate post assembly. See Figure 4.
2. Pull the counterweight chain forward until the counterweight is moved forward about 2' (610mm).
3. Make sure the counterweight is above the shipping screw and replace the shipping screw. See Figure 5.
4. Tie one end of a string to the counterweight chain about 3 links back.
5. Tie the other end of the string to the base plate of the gate post assembly.
6. Carefully handle the gate post assembly to keep the counterweight inside the gate post tube. Keep the counterweight above the shipping screw until the gate post is stood upright.

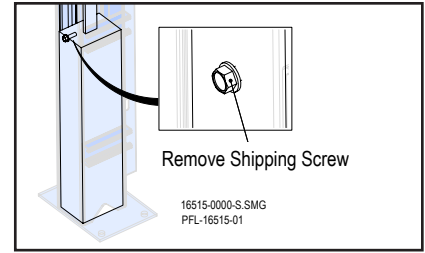

Post Assembly Counterweight
Figure 4

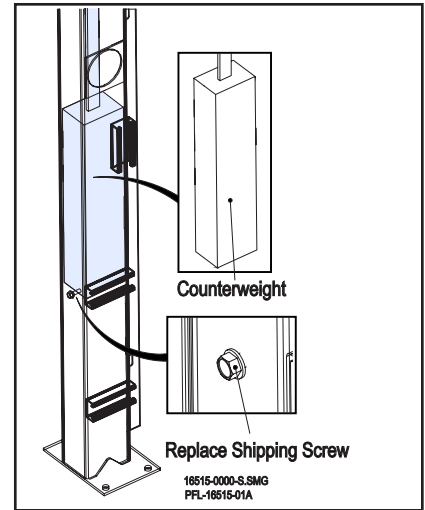

Post Assembly Counterweight
Figure 5

Gate Installation

Single Vertical Acting (SVA) Gate - Horizontal Assembly



MATERIAL HANDLING SOLUTIONS

www.pflow.com
 P 414 352 9000
 F 414 352 9002
 6720 N. Teutonia Ave.
 Milwaukee, WI 53209

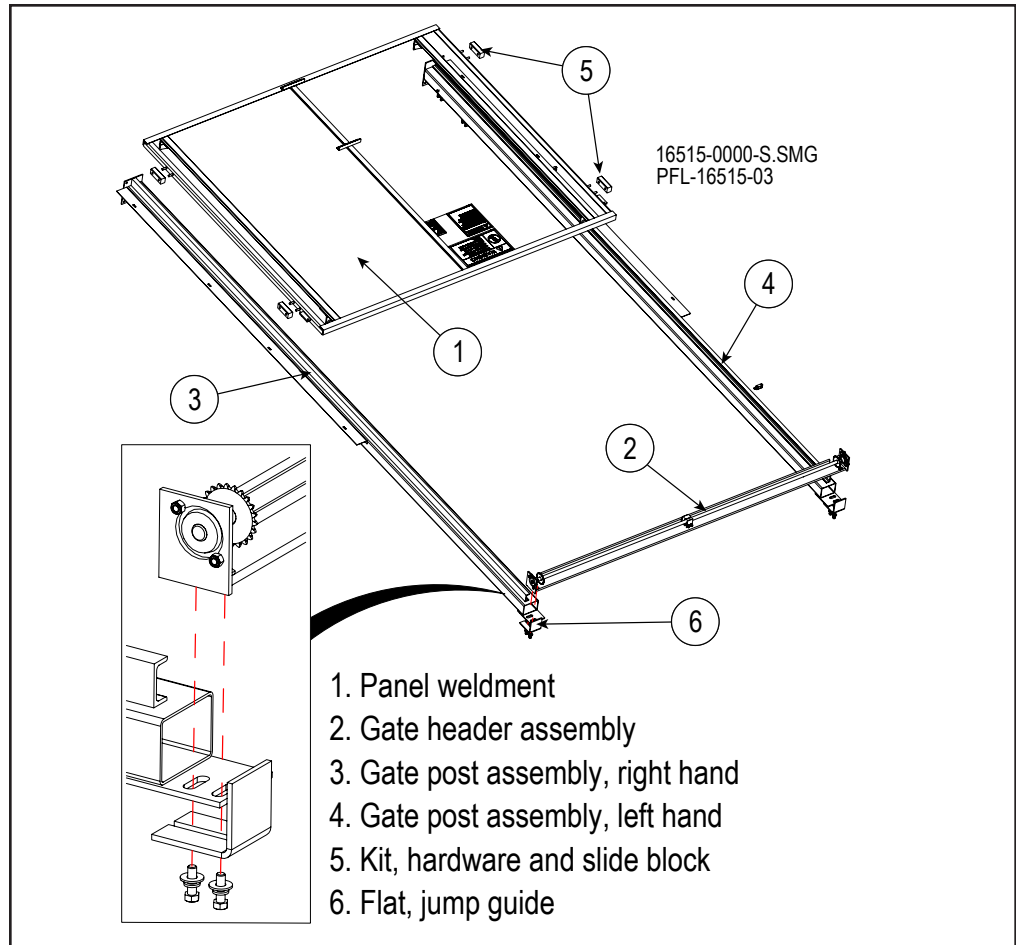

Single VA Gate Layout
 Figure 6

Begin Horizontal Assembly

1. Lay the gate in the proper position to allow for safe handling and efficient fit-up to the VRC. See Figure 6.
2. Lay each gate post (left side and right side) with the panel guide channel facing up, and the channel open towards the middle.

Install the Header

1. Position the gate header with the sprockets facing up and ends flush.
2. Position the chain jump guides to leave space for the chain. See Figure 7.
3. Bolt the chain jump guides and header to the post using four (4) 3/8-16 x 1-1/4" long bolts with lock washers and flat washers (weld-nut on header angle).
4. Align the gate header, making sure the posts are square, and snug the attachment hardware.

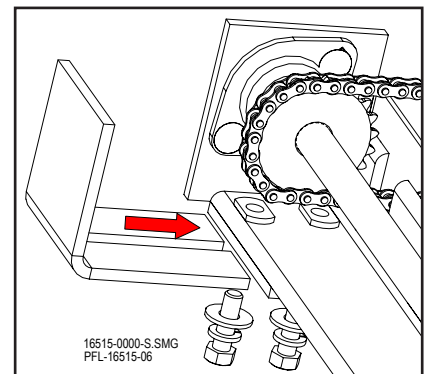

Position Chain Jump Guides
 Figure 7



WARNING



Entanglement hazard! Remove gloves, secure long hair, wear snug-fitting clothing, and avoid wearing jewelry while working with chains.



Crush hazard! Keep hands outside and above the chain. If the lift chain does not reach the wheelblock, carefully work the lift chain around the sprocket until it does reach the wheelblock. Lift the chain from the sides. If the chain drops unaided, the weight of the chain will crush fingers. Do not allow the chain to come off the sprocket.

Header falling hazard! Loosen but do not remove the bolts when adjusting the chain jump guide or the headers. Once assembled, the header can fall if the bolts are completely removed.

NOTE *The chains must be equal in length on both sides of the sprocket to align the position of the counterweight. If the chains are not equal, work the chain on the front side of the sprockets.*

Install the Chains

1. Make sure to eliminate any chain twist. The chain should be straight between the counterweight tab and the sprocket.
2. Remove the #2050 master links from the end of the #35 chain on each post.
3. Place the center link on top of the sprocket. See Figure 8.
4. Thread the chain over the sprocket on the header.
5. Pull the chain tight over the sprocket to remove the slack in the chain without moving the counterweight.
6. Re-attach the #2050 master links to the #35 chain and remove the string.
7. Verify that the chains on each end of the gate are equal in length from the sprocket to the panel.
8. Loosen the header/post hardware to allow the chain jump guide to slide down into position. Do not loosen the hardware to the point that the header falls off. See Figure 9.
9. Set the space between the chain jump guides approximately +/- 1/8" (3mm) from the top of the chain.
10. Securely attach the chain jump guide.

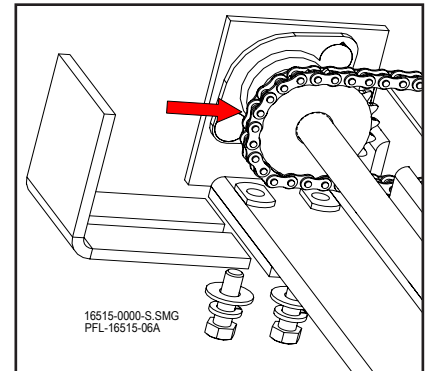

Position Center of Chain
Figure 8

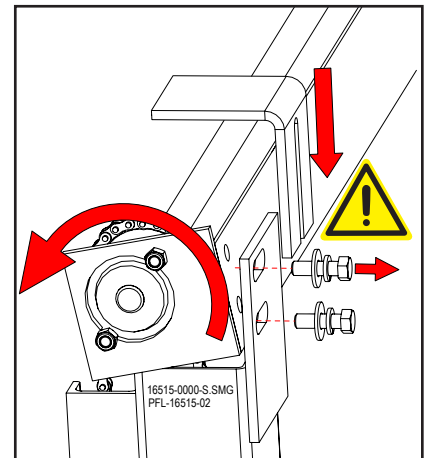

Attach Chain Jump Guides
Figure 9

Gate Installation

Single Vertical Acting (SVA) Gate - Horizontal Assembly



MATERIAL HANDLING SOLUTIONS

www.pflow.com
 P 414 352 9000
 F 414 352 9002
 6720 N. Teutonia Ave.
 Milwaukee, WI 53209

Assemble the Gate Panel

1. Place the gate panel face up between the guide tracks on the gate posts.
2. Insert the guide blocks and attach to the gate panel and guide track. See Figure 10 and Figure 11.
3. Attach the panel bumper to the bottom of the panel. See Figure 12.

Attach the Gate Panel to the Gate Chains

1. Slide the gate panel toward the header. It should move without binding on the guide tracks.
2. Connect the #2050 master link to the gate panel. See Figure 13 and Figure 14.
3. Verify that the chain length is equal on each side.
4. Slide the gate panel to the bottom of the gate posts.

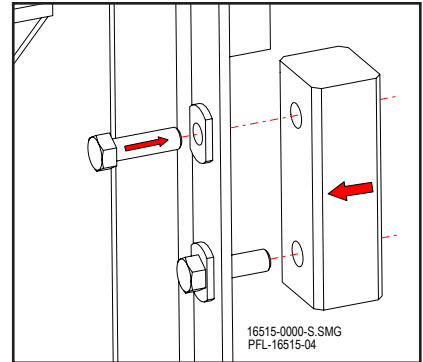

Attach Guide Blocks to Gate Panel
 Figure 10

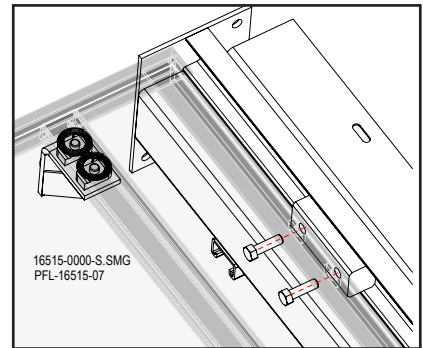

Attach Guide Blocks to Guide Track
 Figure 11

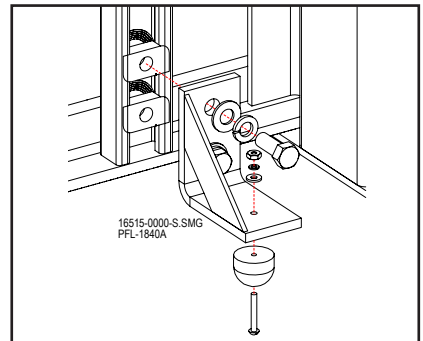

Attach Panel Bumper
 Figure 12



Connect Master Link
 Figure 13

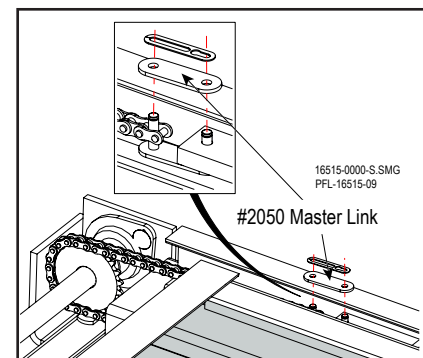

Connect Master Link
 Figure 14

Gate Installation

Single Vertical Acting (SVA) Gate - Horizontal Assembly



MATERIAL HANDLING SOLUTIONS

www.pflow.com
P 414 352 9000
F 414 352 9002
6720 N. Teutonia Ave.
Milwaukee, WI 53209

Raise and Secure the Gate



1. Place a strap around the gate posts to secure and maintain the assembly in place. See Figure 15.

DANGER

Falling gate hazard! Do not lift the VA gate assembly by the header shaft or by a single strap at the center of the header.

2. Place two (2) straps around the header, one near each gate post. Avoid the brackets at the top of each post. See Figure 15.
3. To avoid sudden panel and counterweight movement, slowly raise and secure the gate assembly into place.
4. Tie off or continue to support the gate assembly to prevent tipping or accidental movement.

Align the Gate Assembly

1. Align the center of the gate to the center of the carriage with the front side of the gate panel facing out.
2. Align the back side of the gate panel on the parallel chalk line.
3. Drill and anchor the gate post base plates to the floor with 3/8" anchors, 3-1/2" (89mm) long.

DANGER

Falling gate hazard! The anchor hole depth should always be deeper than the length of the anchor bolt. The recommended wedge anchor size is 3/8" diameter by 3-1/2" (89mm) long.

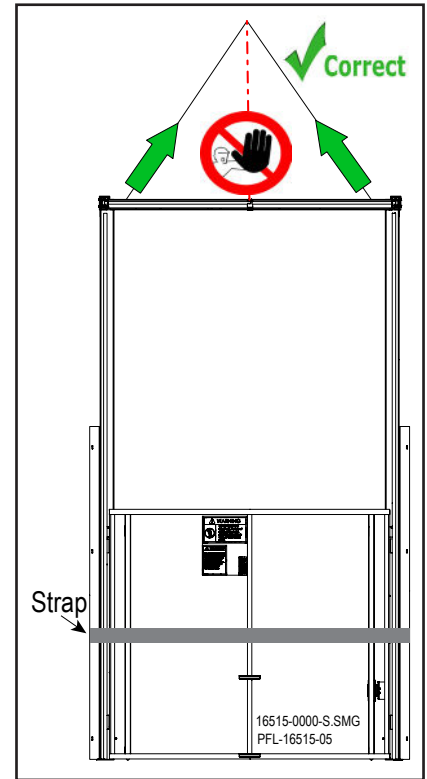

Secure and Lift Gate Assembly
Figure 15

Anchor the Gate Post Base Plates

Gate Installation

Single Vertical Acting (SVA) Gate - Horizontal Assembly



MATERIAL HANDLING SOLUTIONS

www.pflow.com
P 414 352 9000
F 414 352 9002
6720 N. Teutonia Ave.
Milwaukee, WI 53209

Plumb and Square the Gate

1. Plumb and square the gate posts using a plumb bob or a level that is 4' (1,22 m) or longer. See Figure 16.
2. Measure from the gate post to the Vertical Reciprocating Conveyor (VRC) column.

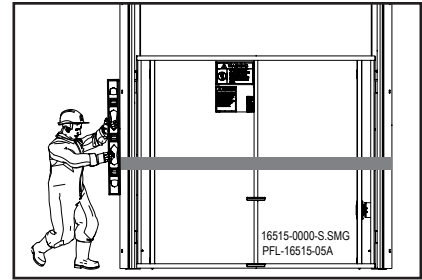

Plumb the Gate
Figure 16

Install Support Braces

1. Cut two (2) 1-1/2" x 1-1/2" (38mm x 38mm) steel angle support braces and weld to each gate post and to the VRC columns or wall. See Figure 17.
2. Tighten all bolts.
3. Confirm that the gate is plumb and square.
4. Weld the gate header to the gate posts. See Figure 18.
5. Remove all straps on the gate.
6. Slowly slide the panel down until the chains are tight and the counterweights are off the shipping screws.
7. Remove the counterweight shipping screw.

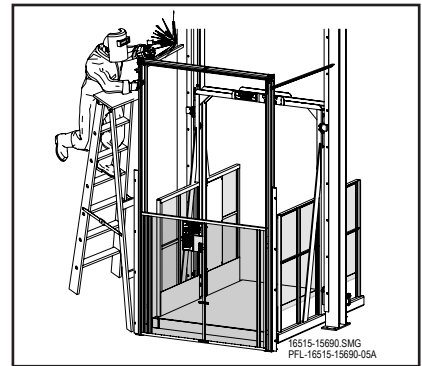

Weld Support Braces
Figure 17

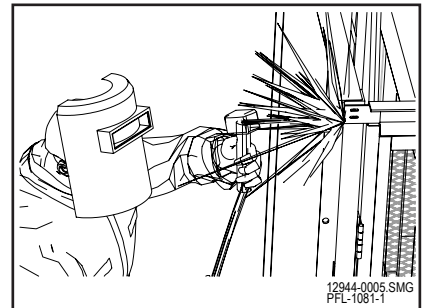

Weld Gate Header to Gate Posts
Figure 18



Adjust the Gate Panel

WARNING

The gate panel must float freely within the guide track or the panel interlock will not operate safely. Make sure the gate is fit properly.

Guide block fit up is important for the gate panel to operate properly and safely. This over-rides any other horizontal alignment dimensions.

1. Snug the gate panel and slide the blocks on one side of the channel guides.
2. Set a +/- 1/8" (3mm) gap between the opposite side guide block and the gate panel. Align the gate post or trim the guide blocks if necessary. The guide block must stay trapped in the guide track. See Figure 19.
3. Make sure the gate header is level horizontally and that the gate posts are plumb and square in both directions. Shim and / or adjust as necessary.
4. Verify that the panel travels up and down evenly and is not binding on the guide tracks.
5. Adjust the bumpers as necessary.
6. Adjust the post spacing or panel slide blocks as necessary.
7. Secure and brace the gate posts to the enclosure panels, the building structure, or the VRC columns as required.
8. Verify that the gate panel moves freely during travel from the top to the bottom of the posts.
9. Verify that the gate panel clears the fully open height. If the counterweight bottoms out in the gate post before the gate panel is fully open, remove chain links to shorten the chain length.
10. Lift the gate panel approximately 2' (610mm) off the floor to verify that the gate panel is properly counterbalanced with panel accessories (e.g., cams, interlock flats) on the panel. The gate panel should remain in this position.
 - If the gate continues to rise, add steel bar stock to the inside bottom center of the gate panel frame.
 - If the gate drops, contact PFlow Industries, Inc. Customer Support Department for instructions.
11. Verify that the counterweight is not hitting the post base plate.

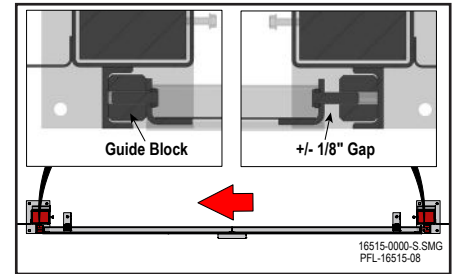

Guide Block Gap
Figure 19

Gate Installation

Single Vertical Acting (SVA) Gate - Horizontal Assembly



MATERIAL HANDLING SOLUTIONS

www.pflow.com
P 414 352 9000
F 414 352 9002
6720 N. Teutonia Ave.
Milwaukee, WI 53209

Install the Gate Panel Interlock

Install the gate panel interlock. Refer to the interlock installation section in the installation manual.

Verify the Gate Operation

1. Verify that the gate panel runs smoothly.
 2. Verify that the gate panel opens when the carriage is present and does not open when the carriage is not present.
 3. Verify that the gate panel remains locked when the carriage leaves the floor level.
-

Gate Installation

Single Vertical Acting (SVA) Gate - Vertical Assembly



MATERIAL HANDLING SOLUTIONS

www.pflow.com
P 414 352 9000
F 414 352 9002
6720 N. Teutonia Ave.
Milwaukee, WI 53209

Establish Placement

Make sure the placement of the gate has been established. Follow instructions beginning on page 2.

Prepare the Chains in the Gate Posts

Make sure the chains and counterweights are prepared before raising the gate posts. Follow instructions beginning on page 3.



Raise and Secure the Gate Posts

CAUTION



Lifting hazard! Components and accessories are heavy. To prevent serious personal injury, use the appropriate lifting apparatus, tie offs, or help when moving, lifting or assembling the components or accessories.

1. Raise, position, and secure one gate post with the back face of the gate post on the parallel chalk line. Make sure the channel on the gate post is facing out and the opening of the channel is facing in. See Figure 20.

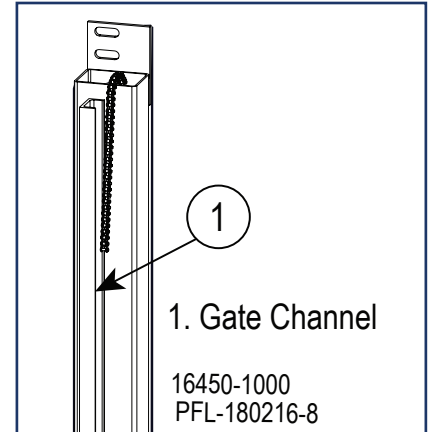

Channel Position
Figure 20

DANGER

Falling gate hazard! The anchor hole depth should always be deeper than the length of the anchor bolt. The recommended wedge anchor size is 3/8" diameter by 3-1/2" (89mm) long.

2. Drill and anchor the gate post base plate to the floor with 3/8" anchors, 3-1/2" (89mm) long.
3. Temporarily brace the gate post to the Vertical Reciprocating Conveyor (VRC) column or wall. See Figure 21.
4. Raise, position, and secure the other gate post with the back face of the gate post on the parallel chalk line. Make sure the channel on the gate post is facing out and the opening of the channel is facing in.
5. Temporarily brace the second gate post to the VRC column or wall. See Figure 21. **Do not anchor this post at this time.**



Temporarily Brace Gate Post
Figure 21



WARNING



Entanglement hazard! Remove gloves, secure long hair, wear snug-fitting clothing, and avoid wearing jewelry while working with chains.



Crush hazard! Keep hands outside and above the chain. If the lift chain does not reach the wheelblock, carefully work the lift chain around the sprocket until it does reach the wheelblock. Lift the chain from the sides. If the chain drops unaided, the weight of the chain will crush fingers. Do not allow the chain to come off the sprocket.

Header falling hazard! Loosen but do not remove the bolts when adjusting the chain jump guide or the headers. Once assembled, the header can fall if the bolts are completely removed.

Install the Header

1. Position the gate header with the sprockets facing out and with the ends flush. See Figure 22.
2. Position the chain jump guides to leave space for the chain. See Figure 23.
3. Bolt the chain jump guides and gate header to the gate post using four (4) 3/8-16 x 1-1/4" long bolts with lock and flat washers (weld-nut on header angle).
4. Align the gate header, making sure the gate posts are square, and snug the attachment hardware.

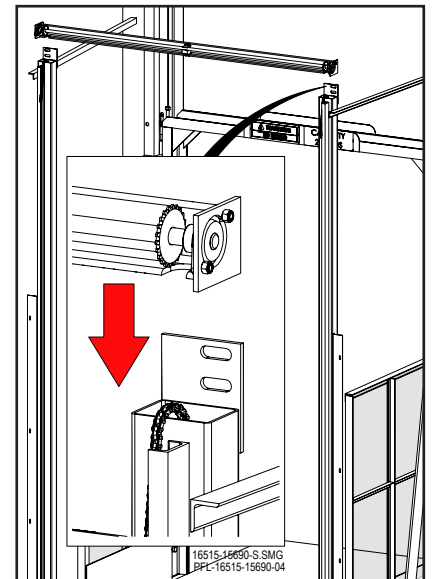

Position Chain Jump Guides
Figure 22

Install the Chains

NOTE *The chains must be equal in length on both sides of the sprocket to align the position of the counterweight. If the chains are not equal, work the chain on the front side of the sprockets.*

1. Make sure to eliminate any chain twist. The chain should be straight between the counterweight tab and the sprocket.
2. Remove the #2050 master links from the end of the #35 chain on each post.
3. Place the center link on top of the sprocket.

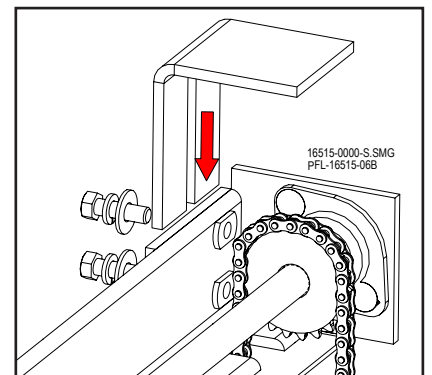

Position Chain Jump Guides
Figure 23

Gate Installation

Single Vertical Acting (VA) Gate - Vertical Assembly



MATERIAL HANDLING SOLUTIONS

www.pflow.com
 P 414 352 9000
 F 414 352 9002
 6720 N. Teutonia Ave.
 Milwaukee, WI 53209

Install the Chains (continued)

4. Thread the chain over the sprockets on the header. See Figure 24.
5. Pull the chain tight over the sprocket to remove the slack in the chain without moving the counterweight.
6. Re-attach the #2050 master links to the #35 chain and remove the strings.
7. Verify that the chains on each end of the gate are equal in length from the sprocket to the panel.
8. Loosen the header/post hardware to allow the chain jump guide to slide down into position. Do not loosen the hardware to the point that the header falls off. See Figure 25.
9. Set the space between the chain jump guides approximately +/- 1/8" (3mm) from the top of the chain.
10. Securely attach the chain jump guide.
11. Remove the counterweight shipping screw.
12. Carefully pull the chain up to move the counterweight above the shipping screw.
13. Re-install the counterweight shipping screw.

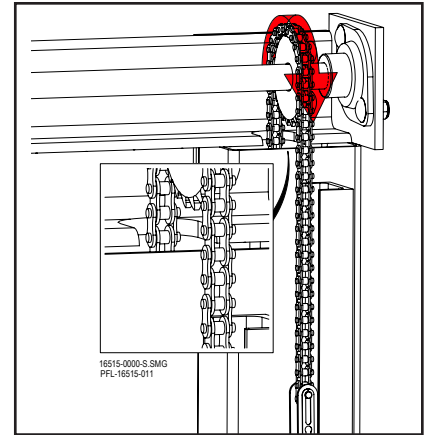

Thread Chain Over the Sprockets
 Figure 24

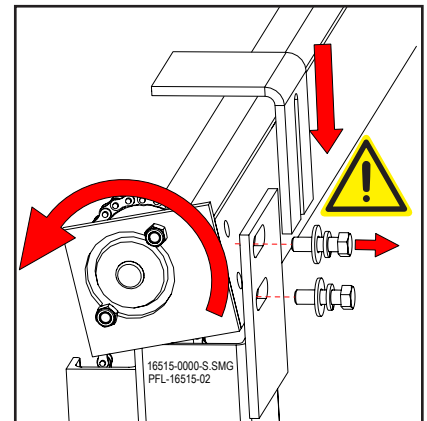

Attach Chain Jump Guides
 Figure 25

Assemble the Gate Panel

1. Place the gate panel between the guide tracks on the gate posts.
2. Insert the guide blocks and attach to the gate panel and guide track. See Figure 26 and Figure 27.
3. Attach the panel bumper at the bottom of the panel. See Figure 28.

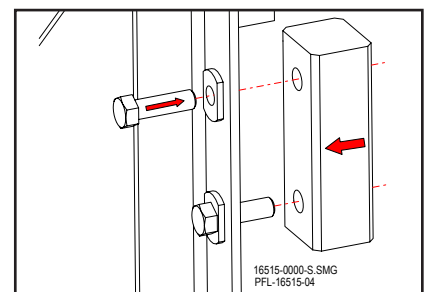

Attach Guide Blocks
 Figure 26

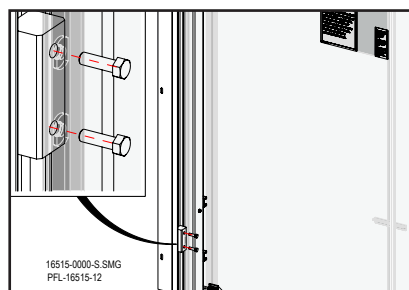

Attach Guide Blocks
 Figure 27

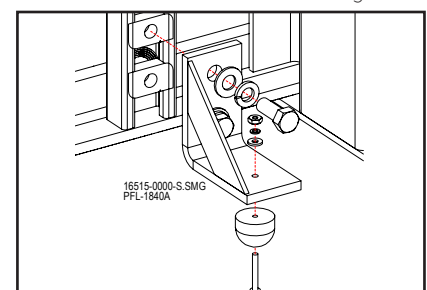

Attach Panel Bumper
 Figure 28

Gate Installation

Single Vertical Acting (SVA) Gate - Vertical Assembly



MATERIAL HANDLING SOLUTIONS

www.pflow.com
P 414 352 9000
F 414 352 9002
6720 N. Teutonia Ave.
Milwaukee, WI 53209

Attach the Gate Panel to the Gate Chains

1. Use an appropriate lifting device to carefully slide the gate panel up towards the gate header. See Figure 29.

NOTE *The gate panel should move up without binding on the guide tracks.*

2. Continue to support the gate panel and attach the gate panel to the chains.
3. Connect the #2050 master links to the gate panel and remove the string.
4. Verify the chain length is equal on each side.

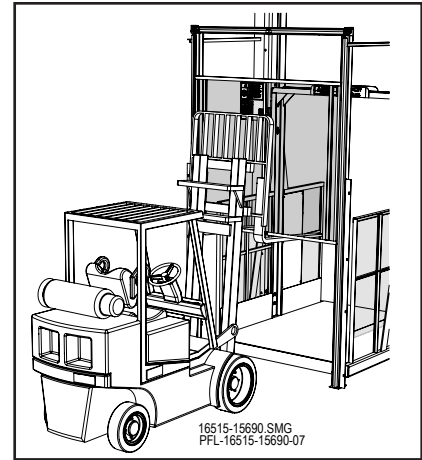

Lift Gate Panel
Figure 29

Install Support Braces

1. Measure from the gate post to the Vertical Reciprocating Conveyor (VRC) column.
2. Cut two (2) 1-1/2" x 1-1/2" (38mm x 38mm) steel angle support braces and weld to each gate post and to the VRC columns or wall. See Figure 30.
3. Confirm that the gate is plumb and square.
4. Tighten all bolts.
5. Weld the gate header to the gate posts. See Figure 31.
6. Slowly slide the panel down until the chains are tight and the counterweights are off the shipping screws.
7. Remove the counterweight shipping screw.

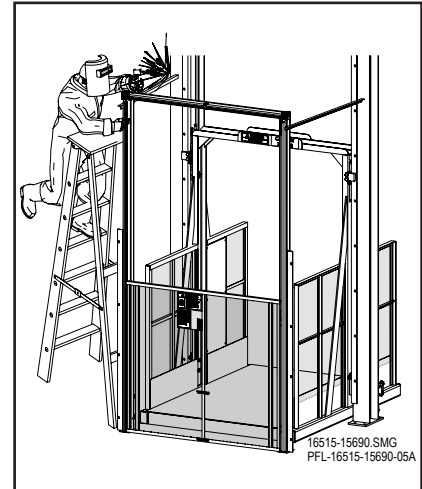

Weld Support Braces
Figure 30

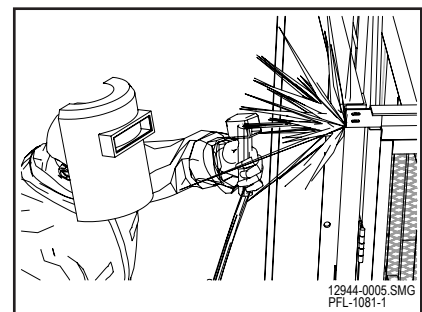

Weld Gate Header to Gate Posts
Figure 31



Adjust the Gate Panel

WARNING

The gate panel must float freely within the guide track or the panel interlock will not operate safely. Make sure the gate is fit properly.

Guide block fit up is important for the gate panel to operate properly and safely. This over-rides any other horizontal alignment dimensions.

1. Snug the gate panel and slide the blocks on one side of the channel guides.
2. Set a +/- 1/8" (3mm) gap between the opposite side guide block and the gate panel. Align the gate post or trim the guide blocks if necessary. The guide block must stay trapped in the guide track. See Figure 32.
3. Make sure the gate header is level horizontally and that the gate posts are plumb and square in both directions. Shim and / or adjust as necessary.
4. Verify that the panel travels up and down evenly and is not binding on the guide tracks.
5. Adjust the bumpers as necessary.
6. Adjust the post spacing or panel slide blocks as necessary.
7. Secure and brace the gate posts to the building structure or the VRC columns as required.
8. Verify that the gate panel moves freely during travel from the top to the bottom of the posts.
9. Verify that the gate panel clears the fully open height. If the counterweight bottoms out in the gate post before the gate panel is fully open, remove chain links to shorten the chain length.
10. Lift the gate panel approximately 2' (610mm) off the floor to verify that the gate panel is properly counterbalanced with panel accessories (e.g., cams, interlock flats) on the panel. The gate panel should remain in this position.
 - If the gate continues to rise, add steel bar stock to the inside bottom center of the gate panel frame.
 - If the gate drops, contact PFlow Industries, Inc. Customer Support Department for instructions.
11. Verify that the counterweight is not hitting the post base plate.

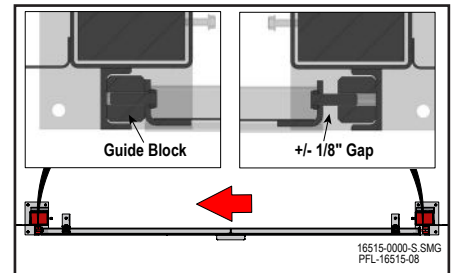

Guide Block Gap
Figure 21

Gate Installation

Single Vertical Acting (SVA) Gate - Vertical Assembly



MATERIAL HANDLING SOLUTIONS

www.pflow.com
P 414 352 9000
F 414 352 9002
6720 N. Teutonia Ave.
Milwaukee, WI 53209

Install the Gate Interlock

Install the gate panel interlock. Refer to the interlock installation section in the installation manual.

Verify the Gate Operation

1. Verify that the gate panel runs smoothly.
 2. Verify that the gate door opens when the carriage is present and does not open when the carriage is not present.
 3. Verify that the gate panel remains locked when the carriage leaves the floor level.
-