

PLAN VIEW — LOWER LEVEL

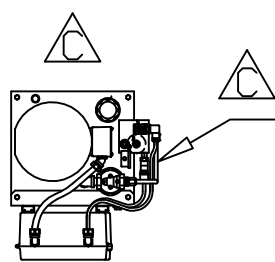

22" WIDE X 24" LONG X 32" HIGH MOTOR/PUMP TO BE LOCATED WITHIN 10'-0" OF LIFT, SHOWN HERE FOR REF. ONLY

D	10/26/18	AEB	18.071
C	4/25/13	AEB	12.101
B	1/28/03	AEB	03.002
A	11/21/00	MRR	00.029
REV	DATE	BY	ECN
REVISIONS			

NOTES:

- 1.) ALL DIMENSIONS SHOWN REPRESENTATIVE OF AVERAGE APPLICATIONS. THESE DIMENSIONS WILL CHANGE BASED ON APPLICATION SPECIFIC CONDITIONS.
- 2.) CONSULT FACTORY BEFORE CONSTRUCTION OF PIT.
- 3.) IF CARRIAGE IS OVER 8'-0" SQ. & 4000#, CONSULT FACTORY.



MATERIAL HANDLING SOLUTIONS

6720 N. TEUTONIA AVE.
MILWAUKEE, WI 53209
P (414) 352-9000
F (414) 352-9002

THIS PRINT INCLUDING THE DESIGN AND PRINCIPLES OF CONSTRUCTION IS THE PROPERTY OF PFLOW INDUSTRIES, INC. AND MUST BE RETURNED ON DEMAND. THE INFORMATION CONTAINED HEREON IS CONFIDENTIAL AND MAY NOT BE USED NOR DIVULGED WITHOUT PERMISSION OF PFLOW INDUSTRIES, INC.

TITLE

SERIES 21 (CANTILEVER)
DIMENSIONAL INFORMATION

DATE	3/19/96	SCALE	N.T.S.	DRAWING NUMBER	9424-0007	SHT	1	REV	D
DRAWN	PCP	CHECKED				OF	4		

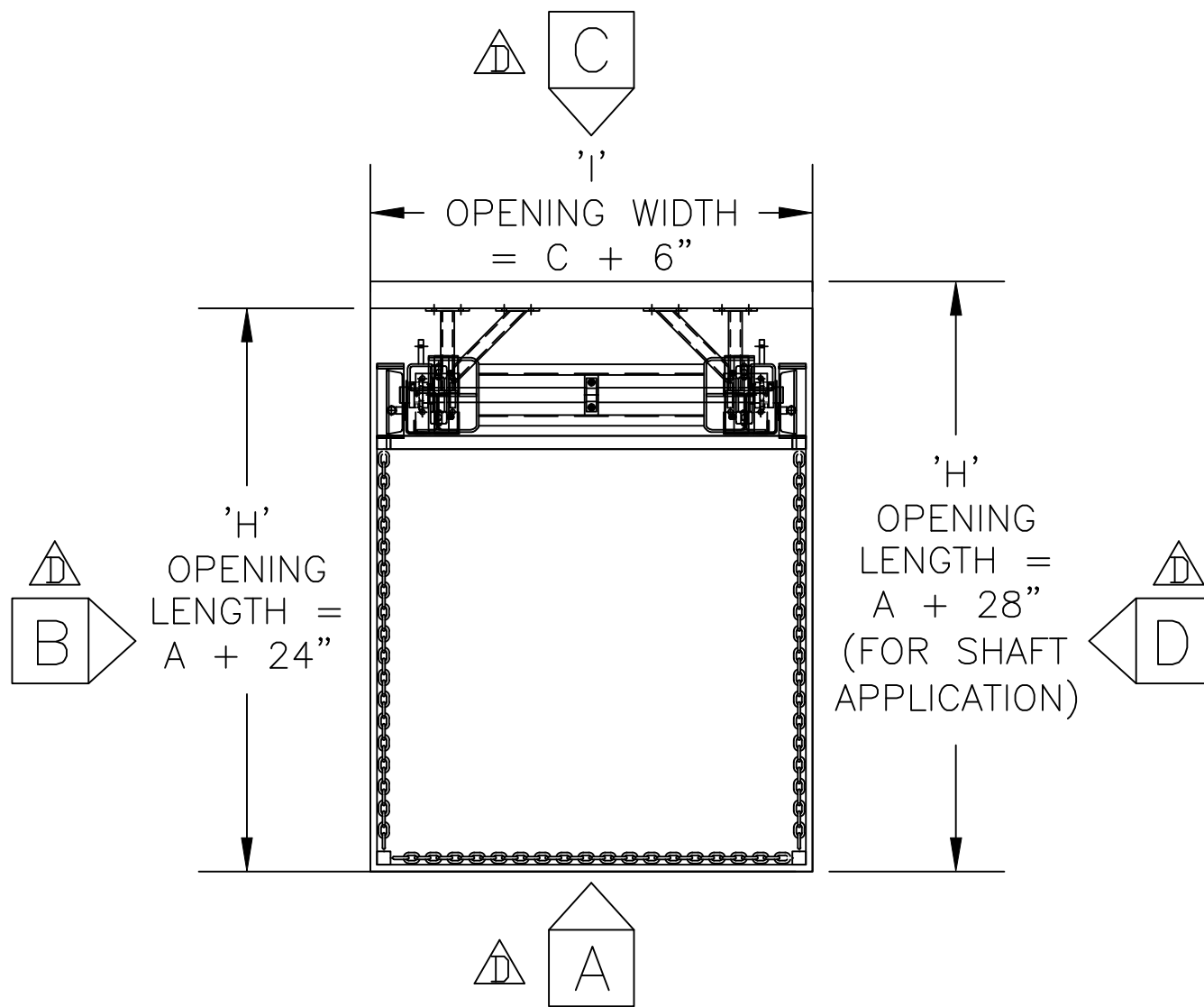

PLAN VIEW – UPPER LEVEL

D	10/26/18	AEB	18.071
C	4/25/13	AEB	12.101
B	1/28/03	AEB	03.002
A	11/21/00	MRR	00.029
REV	DATE	BY	ECN
REVISIONS			

NOTES:

- 1.) ALL DIMENSIONS SHOWN REPRESENTATIVE OF AVERAGE APPLICATIONS. THESE DIMENSIONS WILL CHANGE BASED ON APPLICATION SPECIFIC CONDITIONS.
- 2.) CONSULT FACTORY BEFORE CONSTRUCTION OF PIT.
- 3.) IF CARRIAGE IS OVER 8'-0" SQ. & 4000#, CONSULT FACTORY.



MATERIAL HANDLING SOLUTIONS

6720 N. TEUTONIA AVE.
MILWAUKEE, WI 53209
P (414) 352-9000
F (414) 352-9002

THIS PRINT INCLUDING THE DESIGN AND PRINCIPLES OF CONSTRUCTION IS THE PROPERTY OF PFLOW INDUSTRIES, INC. AND MUST BE RETURNED ON DEMAND. THE INFORMATION CONTAINED HEREON IS CONFIDENTIAL AND MAY NOT BE USED NOR DIVULGED WITHOUT PERMISSION OF PFLOW INDUSTRIES, INC.

TITLE

SERIES 21 (CANTILEVER)
DIMENSIONAL INFORMATION

DATE	3/19/96	SCALE	N.T.S.	DRAWING NUMBER	9424-0007	SHT	2	REV	D
DRAWN	PCP	CHECKED				OF	4		

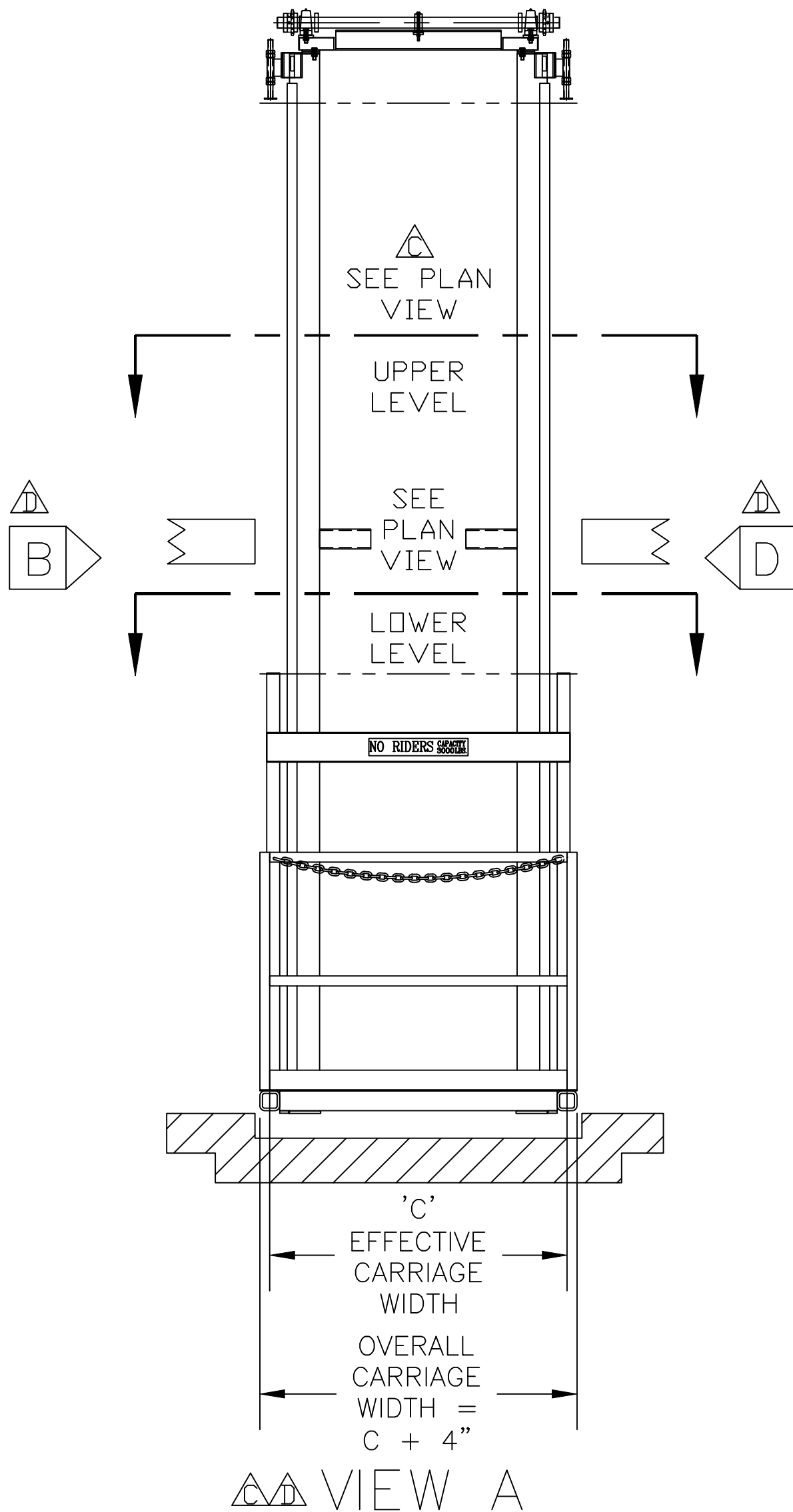

D	10/26/18	AEB	18.071
C	4/25/13	AEB	12.101
B	1/28/03	AEB	03.002
A	11/21/00	MRR	00.029
REV	DATE	BY	ECN

REVISIONS

- NOTES:
- 1.) ALL DIMENSIONS SHOWN REPRESENTATIVE OF AVERAGE APPLICATIONS. THESE DIMENSIONS WILL CHANGE BASED ON APPLICATION SPECIFIC CONDITIONS.
 - 2.) CONSULT FACTORY BEFORE CONSTRUCTION OF PIT.
 - 3.) IF CARRIAGE IS OVER 8'-0" SQ. & 4000#, CONSULT FACTORY.



MATERIAL HANDLING SOLUTIONS

6720 N. TEUTONIA AVE.
MILWAUKEE, WI 53209
P (414) 352-9000
F (414) 352-9002

THIS PRINT INCLUDING THE DESIGN AND PRINCIPLES OF CONSTRUCTION IS THE PROPERTY OF PFLOW INDUSTRIES, INC. AND MUST BE RETURNED ON DEMAND. THE INFORMATION CONTAINED HEREON IS CONFIDENTIAL AND MAY NOT BE USED NOR DIVULGED WITHOUT PERMISSION OF PFLOW INDUSTRIES, INC.

TITLE					SERIES 21 (CANTILEVER) DIMENSIONAL INFORMATION				
DATE	3/19/96	SCALE	N.T.S.	DRAWING NUMBER			SHT	3	REV
DRAWN	PCP	CHECKED		9424-0007			OF	4	D

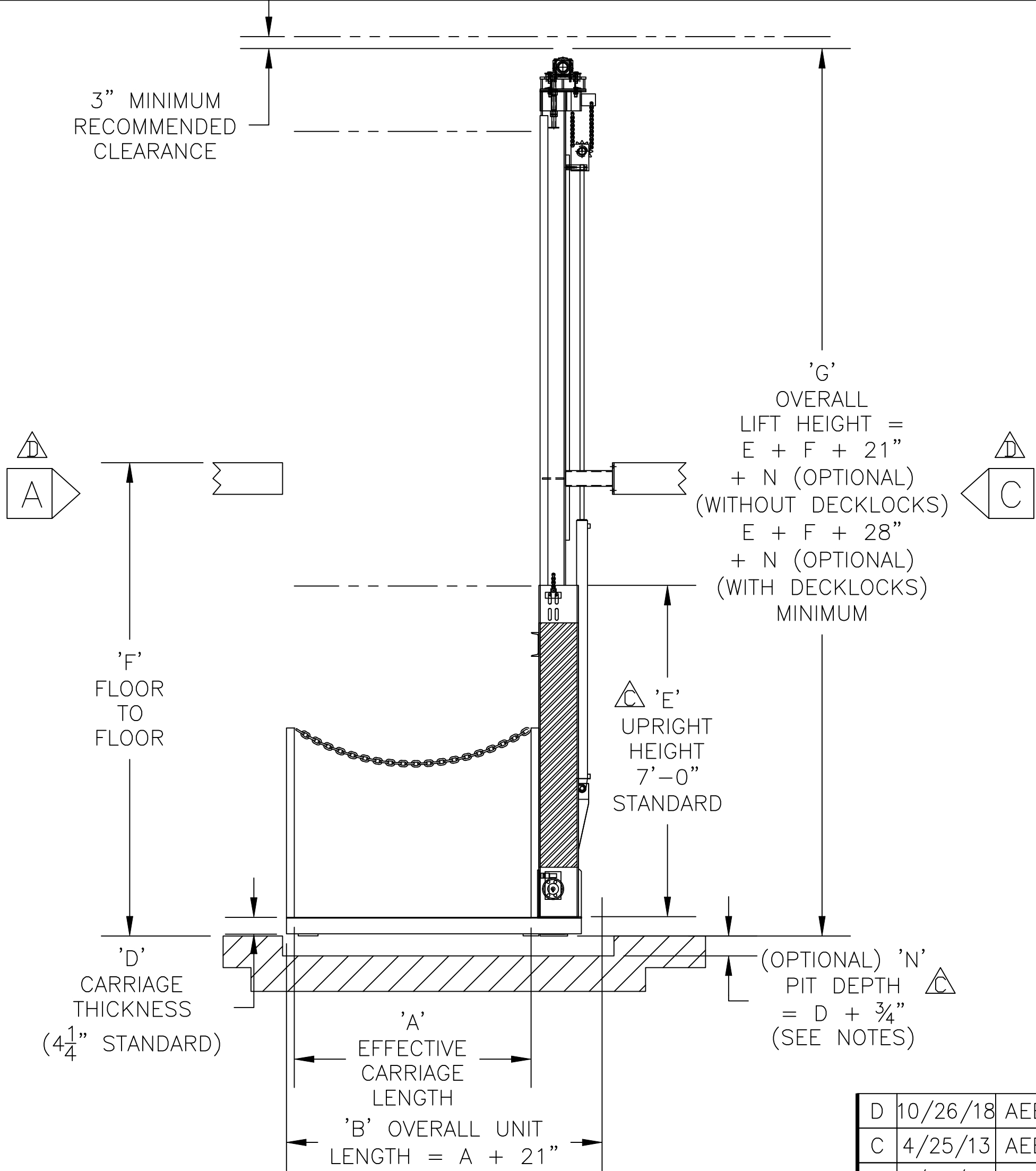

VIEW D

D	10/26/18	AEB	18.071
C	4/25/13	AEB	12.101
B	1/28/03	AEB	03.002
A	11/21/00	MRR	00.029
REV	DATE	BY	ECN
REVISIONS			

- NOTES:
- 1.) ALL DIMENSIONS SHOWN REPRESENTATIVE OF AVERAGE APPLICATIONS. THESE DIMENSIONS WILL CHANGE BASED ON APPLICATION SPECIFIC CONDITIONS.
 - 2.) CONSULT FACTORY BEFORE CONSTRUCTION OF PIT.
 - 3.) IF CARRIAGE IS OVER 8'-0" SQ. & 4000#, CONSULT FACTORY.



MATERIAL HANDLING SOLUTIONS

6720 N. TEUTONIA AVE.
 MILWAUKEE, WI 53209
 P (414) 352-9000
 F (414) 352-9002

THIS PRINT INCLUDING THE DESIGN AND PRINCIPLES OF CONSTRUCTION IS THE PROPERTY OF PFLOW INDUSTRIES, INC. AND MUST BE RETURNED ON DEMAND. THE INFORMATION CONTAINED HEREON IS CONFIDENTIAL AND MAY NOT BE USED NOR DIVULGED WITHOUT PERMISSION OF PFLOW INDUSTRIES, INC.				
TITLE SERIES 21 (CANTILEVER) DIMENSIONAL INFORMATION				
DATE	3/19/96	SCALE	N.T.S.	DRAWING NUMBER
DRAWN	PCP	CHECKED		9424-0007
SHT	4	REV		
OF	4			D

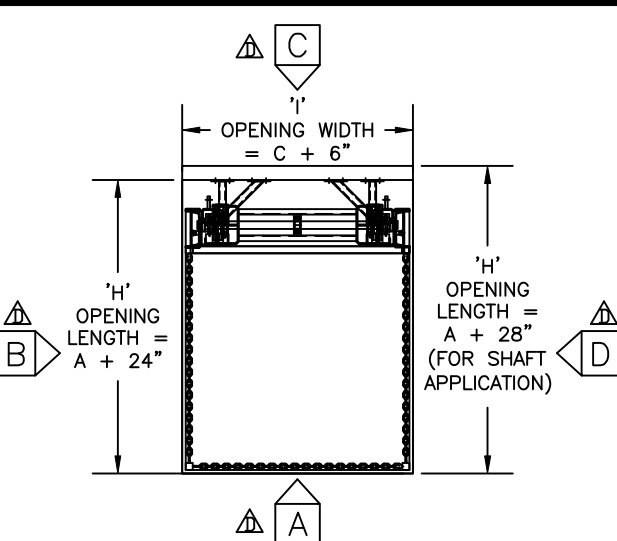

PLAN VIEW - UPPER LEVEL

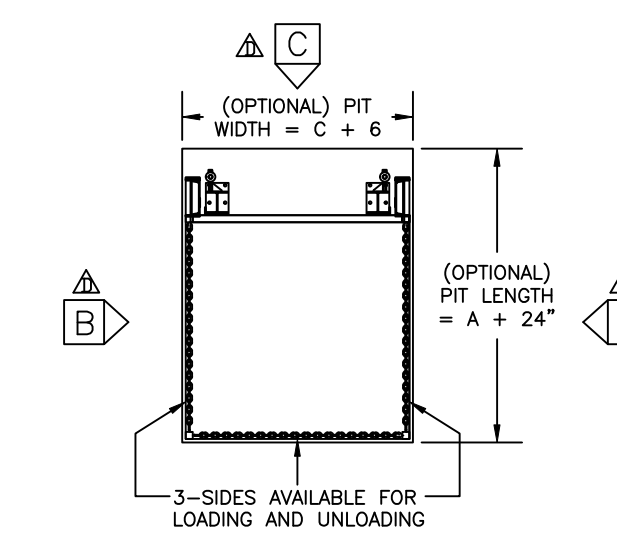

PLAN VIEW - LOWER LEVEL

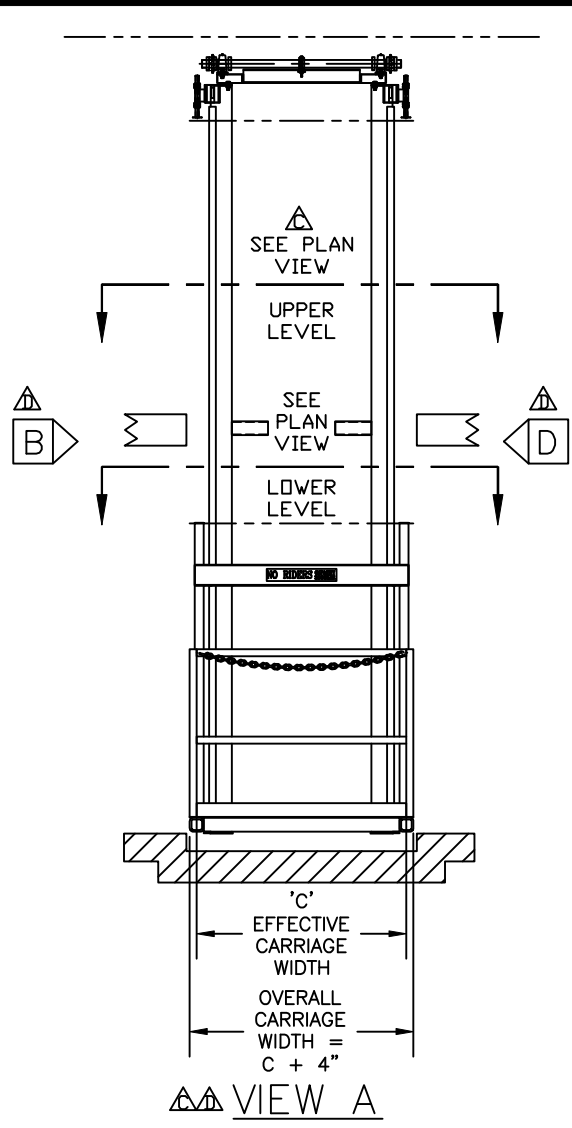

VIEW A

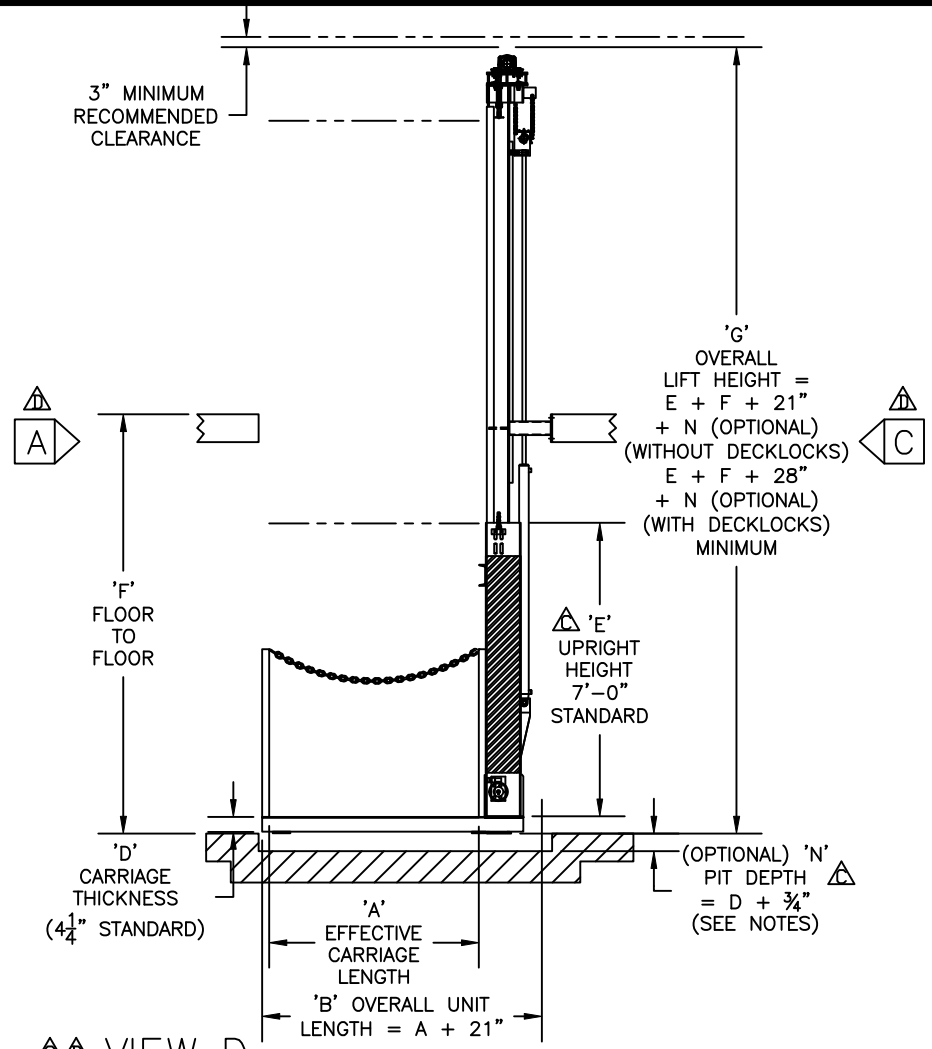

VIEW D

- NOTES:
- 1.) ALL DIMENSIONS SHOWN REPRESENTATIVE OF AVERAGE APPLICATIONS. THESE DIMENSIONS WILL CHANGE BASED ON APPLICATION SPECIFIC CONDITIONS.
 - 2.) CONSULT FACTORY BEFORE CONSTRUCTION OF PIT.
 - 3.) IF CARRIAGE IS OVER 8'-0"SQ. & 4000#, CONSULT FACTORY.

PFLOW INDUSTRIES MATERIAL HANDLING SOLUTIONS 6720 N. TEUTONIA AVE. MILWAUKEE, WI 53209 P (414) 352-9000 F (414) 352-9002

THIS PRINT INCLUDING THE DESIGN AND PRINCIPLES OF CONSTRUCTION IS THE PROPERTY OF PFLOW INDUSTRIES, INC. AND MUST BE RETURNED ON DEMAND. THE INFORMATION CONTAINED HEREON IS CONFIDENTIAL AND MAY NOT BE USED NOR DIVULGED WITHOUT PERMISSION OF PFLOW INDUSTRIES, INC.

REV	DATE	BY	ECN	DATE	SCALE	DRAWING NUMBER	SHT	REV
D	10/26/18	AEB	18.071	3/19/96	N.T.S.	9424-0007	1	D
C	4/25/13	AEB	12.101				1	
B	1/28/03	AEB	03.002				1	
A	11/21/00	MRR	00.029				1	
TITLES				SERIES 21 (CANTILEVER)		DIMENSIONAL INFORMATION		
REVISIONS				DRAWN	CHECKED			
				PCP				

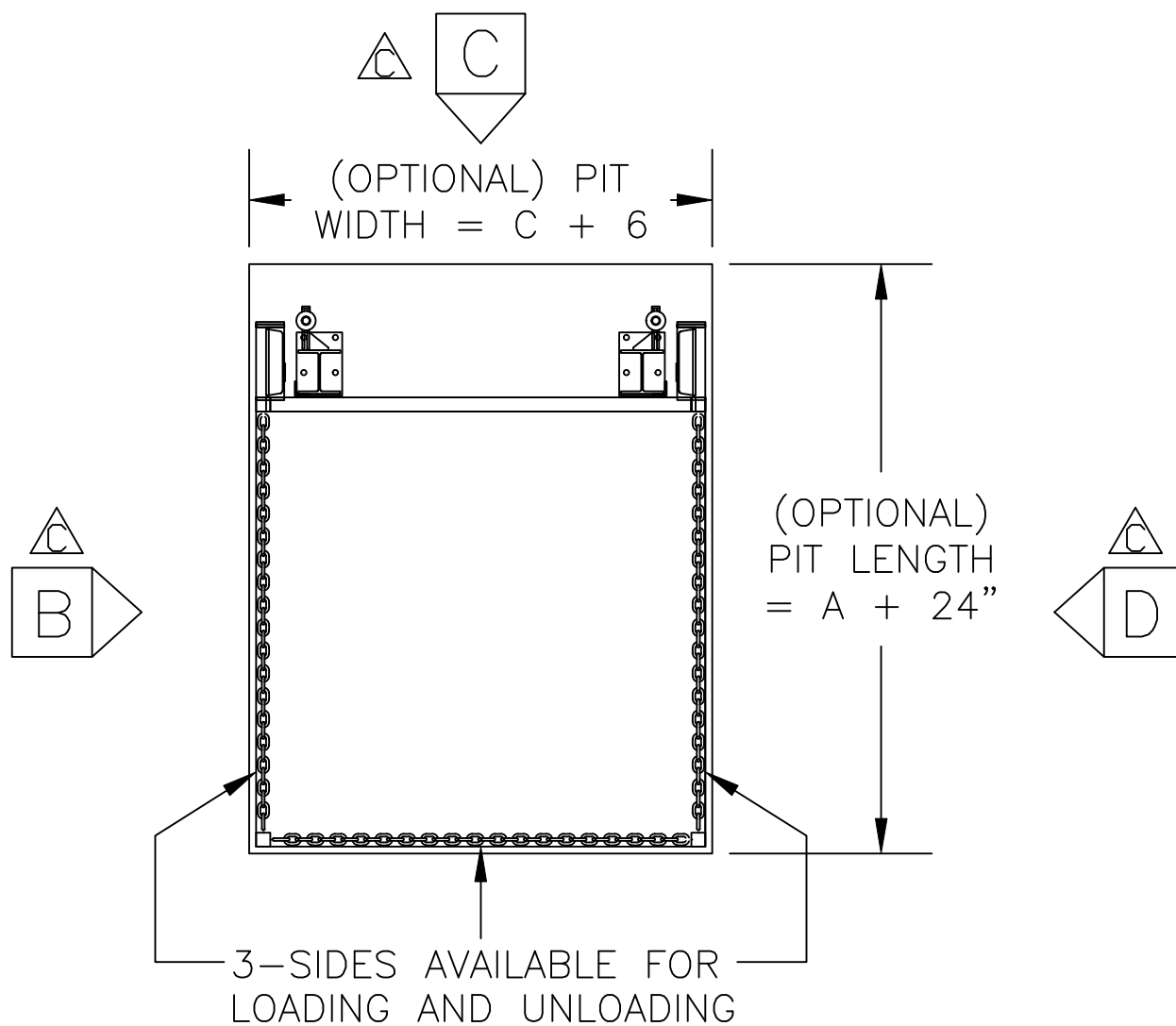

PLAN VIEW — LOWER LEVEL

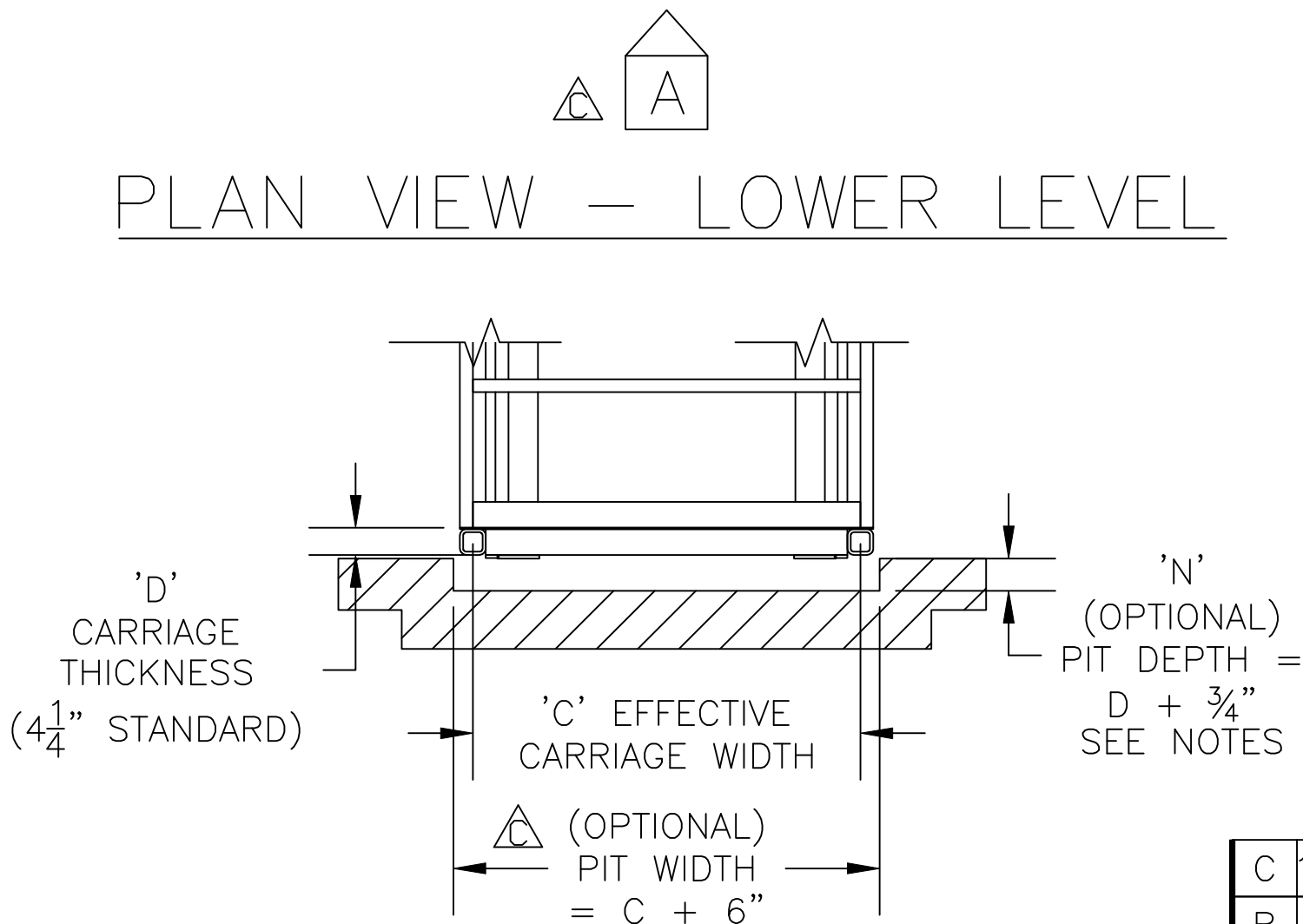

VIEW A

'N'
(OPTIONAL)
PIT DEPTH =
 $D + \frac{3}{4}$ "
SEE NOTES

C	10/26/18	AEB	18.071
B	4/25/13	AEB	12.101
A	3/5/03	DMB	03.007
REV	DATE	BY	ECN
REVISIONS			

NOTES:

- 1.) ALL DIMENSIONS SHOWN REPRESENTATIVE OF AVERAGE APPLICATIONS. THESE DIMENSIONS WILL CHANGE BASED ON APPLICATION SPECIFIC CONDITIONS.
- 2.) CONSULT FACTORY BEFORE CONSTRUCTION OF PIT.
- 3.) IF CARRIAGE IS OVER 8'-0" SQ. & 4000#, CONSULT FACTORY.



MATERIAL HANDLING SOLUTIONS

6720 N. TEUTONIA AVE.
MILWAUKEE, WI 53209
P (414) 352-9000
F (414) 352-9002

THIS PRINT INCLUDING THE DESIGN AND PRINCIPLES OF CONSTRUCTION IS THE PROPERTY OF PFLOW INDUSTRIES, INC. AND MUST BE RETURNED ON DEMAND. THE INFORMATION CONTAINED HEREON IS CONFIDENTIAL AND MAY NOT BE USED NOR DIVULGED WITHOUT PERMISSION OF PFLOW INDUSTRIES, INC.

TITLE					SERIES 21 (CANTILEVER) PIT DIMENSIONAL INFORMATION						
DATE	1/23/03	SCALE	N.T.S.	DRAWING NUMBER	9424-0007-PIT			SHT	1	REV	C
DRAWN	DMB	CHECKED						OF	1		